

ART PROJECTS FOR KIDS

HALLOWEEN

DRAWINGS



“Halloween Drawing” FAQs

1. Why are these tutorials formatted for a 6” x 9” sheet of paper?

Working on what is essentially a half sheet of drawing paper has many benefits. You can:

- Save time. Most art can be completely drawn and colored in 45 minutes.
- Save paper. Just chop your 9” x 12” paper in half.
- Make nice cards. Fold a full sheet in half and draw on the front.
- Make art for your Recycled Art Journals. If not, any other size paper works fine too.



2. What is a Recycled Art Journal?

After looking for years for an easy and inexpensive journal system for my 500+ students, I discovered that half sheets of drawing paper, punched with two holes on one end, held together by book rings, made a journal that could grow throughout the year. It got its name from using old cardboard for the covers.

Here are a few of the reasons why I like this system so much:

It saves money. Each journal requires only two book rings per student, art paper cut in half, a paper cutter, and a two-hole punch. The covers are free if you recycle by having students bring in old cereal boxes, toy boxes, etc.

It saves time. No more sorting of artwork. Each student is responsible for finding their journal and putting away their own art at the end of each class.

It cuts down on unfinished student work. The 6” x 9” paper is much easier to finish than the usual 9” x 12” size, especially if your art class is 45 min. or so. Have early finishers? They can easily flip back and work on incomplete projects.

It helps art get home safely. Single projects that go home in backpacks often get folded and beat up in the process. This guarantees some protection for the art until the end of the year.

Parents love it. They can save all their child’s work in one place too.

Watching journals grow instills a sense of pride. Students start to appreciate that some things take time, like making a large book of one’s own art.



3. What do you need to make Recycled Art Journals?

Cardboard. 6" X 9". Some options are old cereal boxes, toy boxes, anything that is clean, large and easy to cut with a paper cutter. Plain cardboard is good too.

Paper. 6" X 9". Easy if you start with 9" x 12" and then just cut in half.

Paper Cutter. I prefer the old dangerous type with the arm that comes down, because it works fast and cuts through even heavy cardboard. The sliding arm type works too though, especially if you stick to lighter weight food boxes.

Two-hole Punch. There are many types, all seem to work well. Mine came from Staples, cost about \$15, and lasted for years.

Book Rings. If you just need a few, Staples sells 16 for \$5. If you need bulk, try searching Amazon. I found boxes of 100 for \$10. I recommend the 1.5" size so your journal has room to grow.



4. What media is recommended for these Halloween drawing tutorials?

You could use crayons or pencil crayons for these tutorials, but the Halloween theme offers a good excuse for using lots of bright colors – especially lots of orange and black!

I recommend tracing the main drawing with a RediSharp permanent marker (they don't bleed through and make the inside of your card look bad) and a thin Sharpie for smaller details.

My samples were colored with Stabilo® Power markers, the large set of 30. They have lots of good skin colors, many shades to choose from, AND keep working for days even after a cap has been left off.



Halloween Drawing

Table of Contents



Bat
pg 5-7



Black Cat
pg 8-10



Broom
pg 11-13



Candy
pg 14-16



Cauldron
pg 17-19



Fairy Costume
pg 20-22



Frankenstein Costume
pg 23-25



Ghost
pg 26-28



Haunted House
pg 29-31



Maple Leaf
pg 32-34



Owl Face
pg 35-37



Owl in Tree
pg 38-40



Pickup Truck
pg 41-43



Pumpkin Carved
pg 44-46



Scarecrow
pg 47-49



Sheriff Costume
pg 50-52



Skull
pg 53-55



Spider
pg 56-58



Spider Web
pg 59-61



Super Girl Costume
pg 62-64



Vampire Costume
pg 65-67



Vintage Cat Face
pg 68-70



Witch Costume
pg 71-73

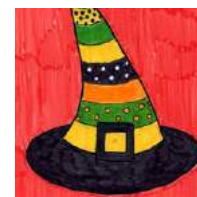

Witch Hat
pg 74-76



Witch Legs
pg 77-79

Flying Bat

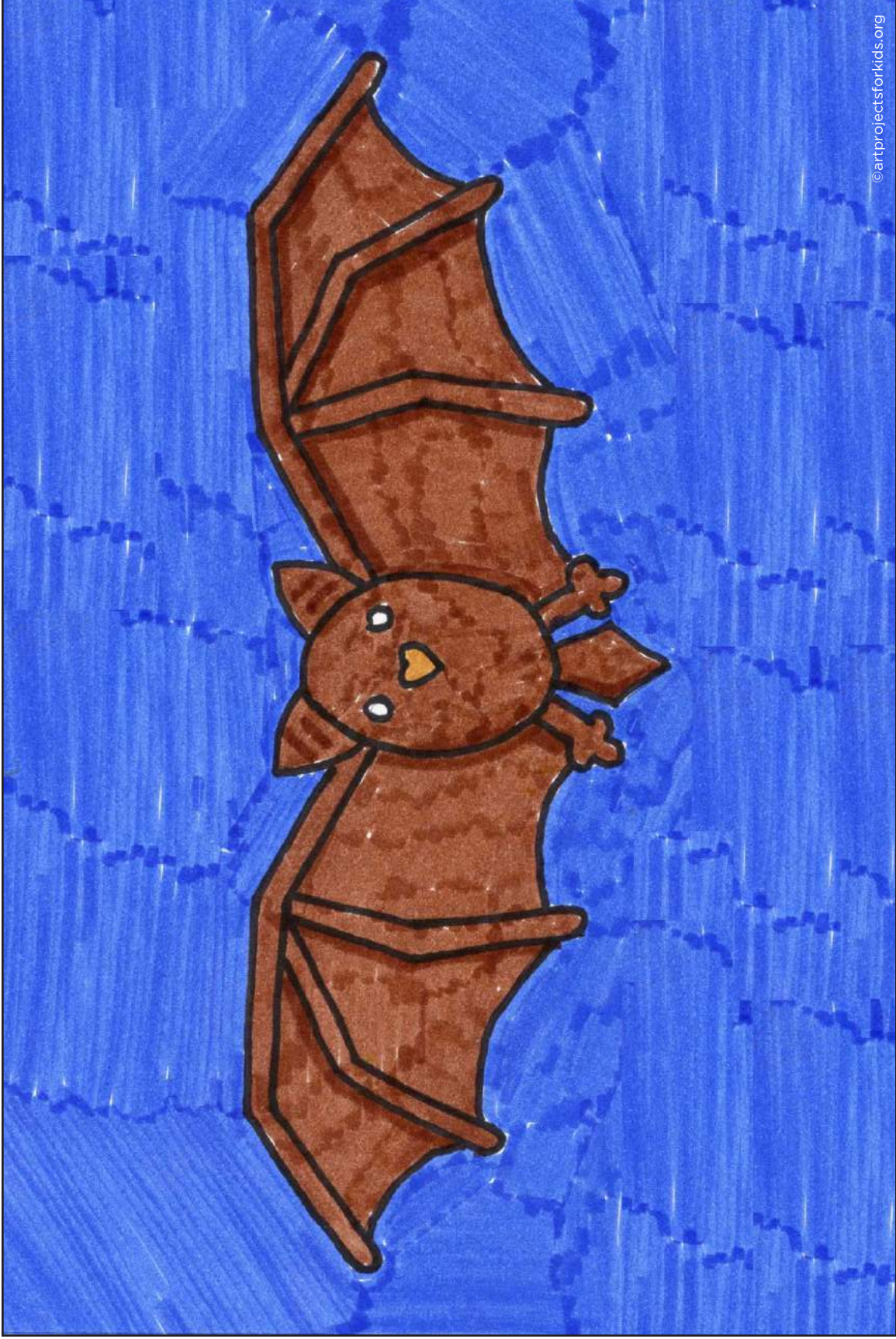

Flying Bat

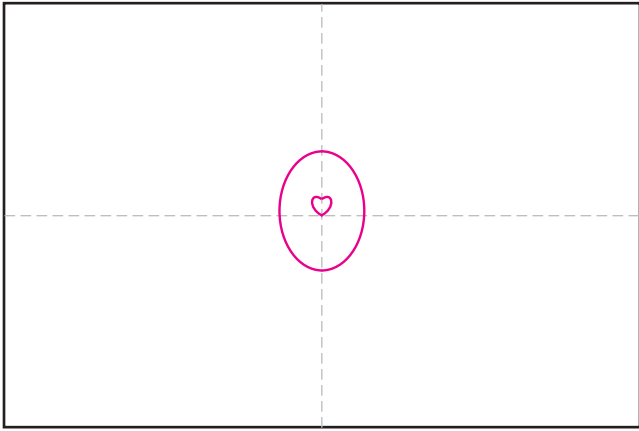

1. Draw a small heart shaped nose, and then an oval around it.

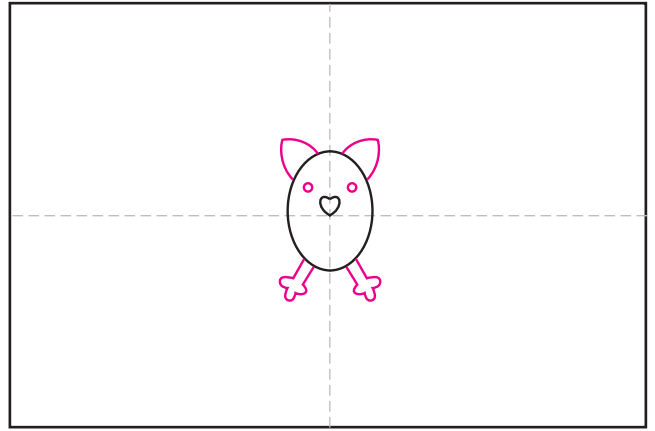

2. Add the eyes, ears, and simple feet.

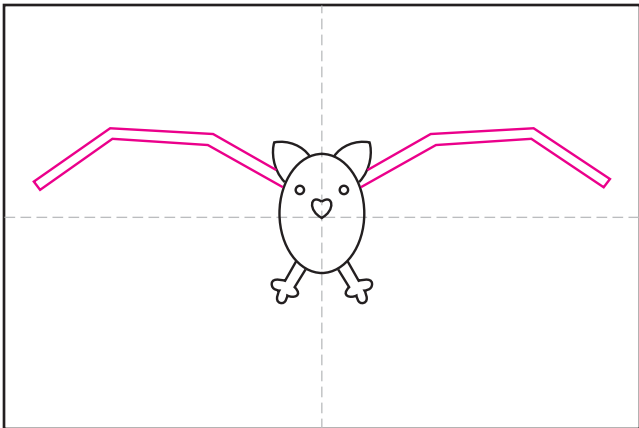

3. Draw the top finger bones. Make them as symmetrical as you can.

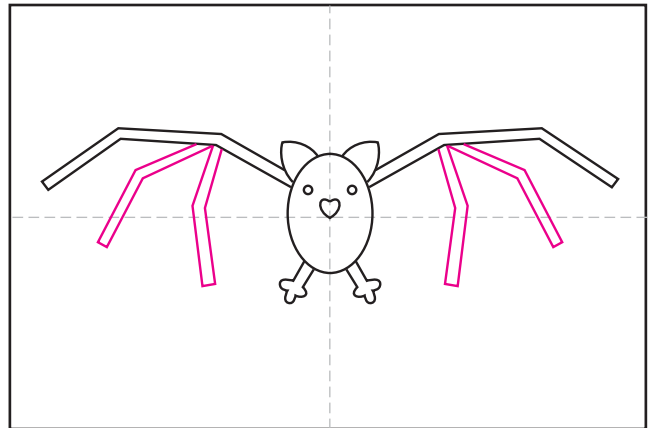

4. Add two more finger bones on each side. Make them as symmetrical as you can.

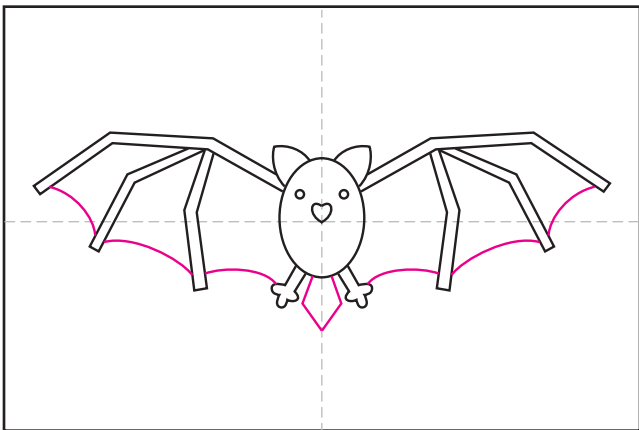

5. Connect the fingers with a curved line to draw the membrane. Add a small tail between the legs.



6. Trace the drawing with a black marker. Fill in carefully with your favorite markers. Draw an extra line by the bone lines to make a shadow.

Flying Bat

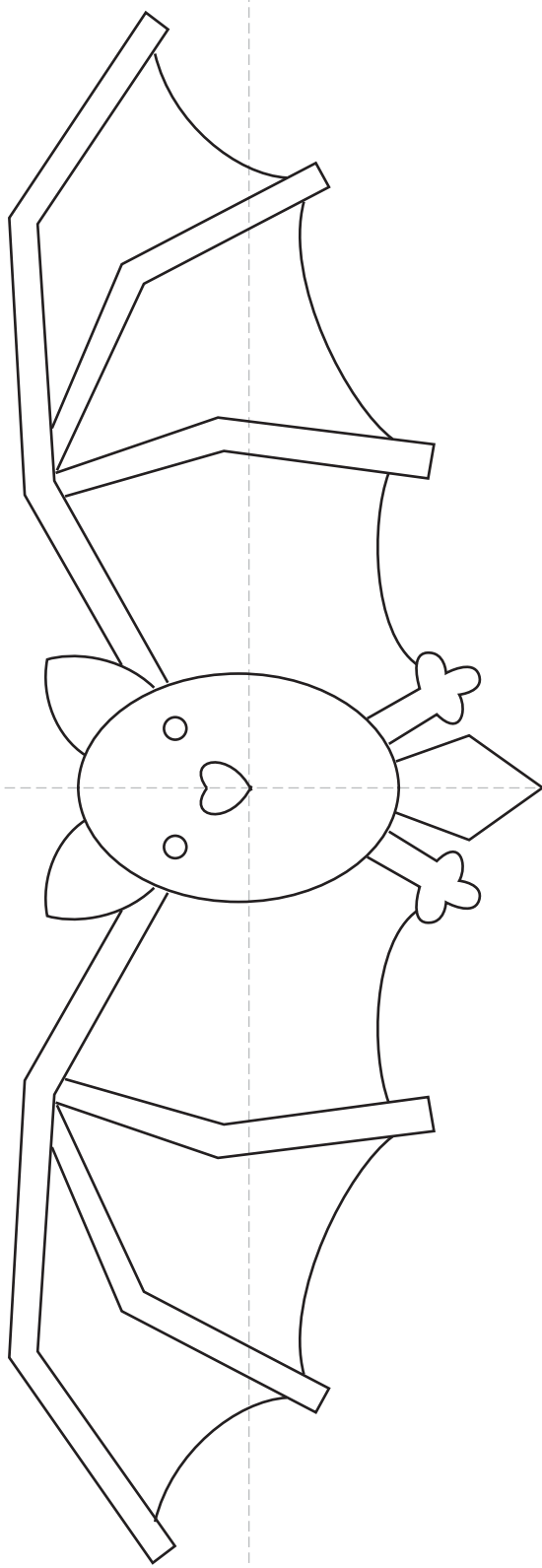

Black Cat



Black Cat

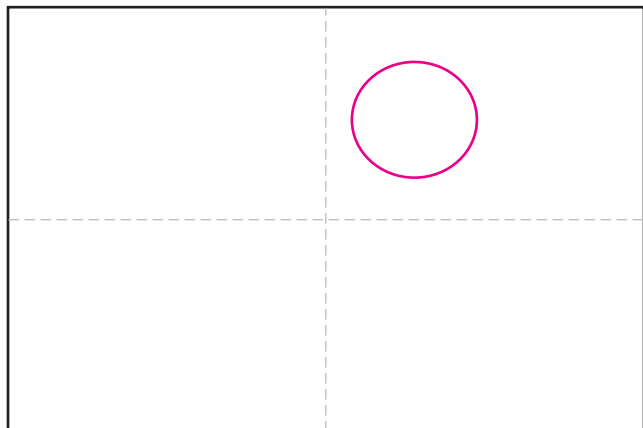

1. Start with drawing a circle for the head.

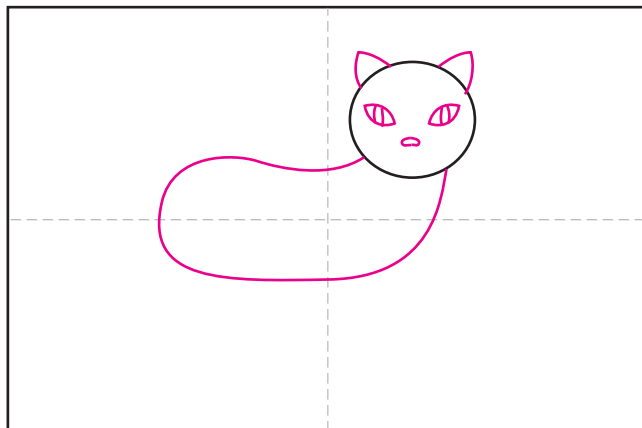

2. Add the body shape underneath. Add the eyes, nose and ears.

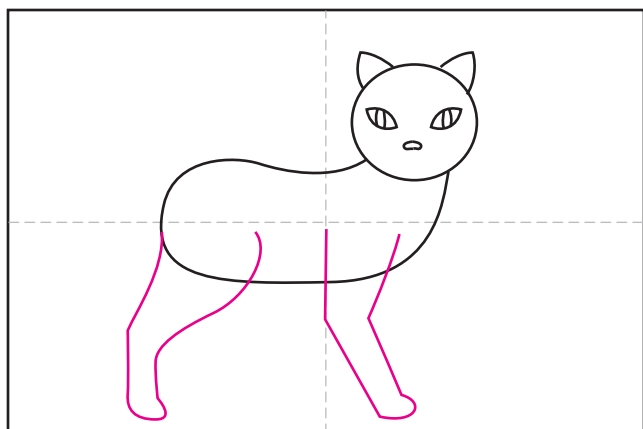

3. Draw the front and back leg.

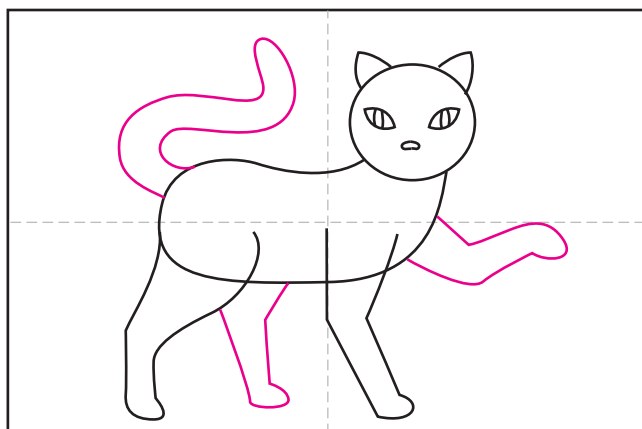

4. Add another front and back leg on the other side. Draw a curly tail.

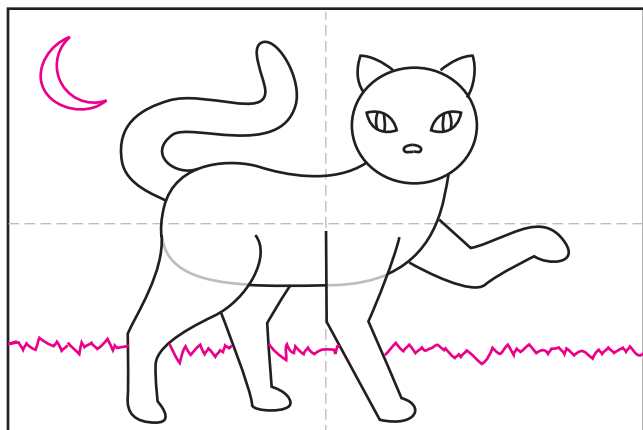

5. Erase the lines inside the legs as shown. Add a grassy horizon line and moon in the sky.



6. Trace the cat with a gray marker. Fill in carefully with black, trying not to cover up any gray.

Black Cat

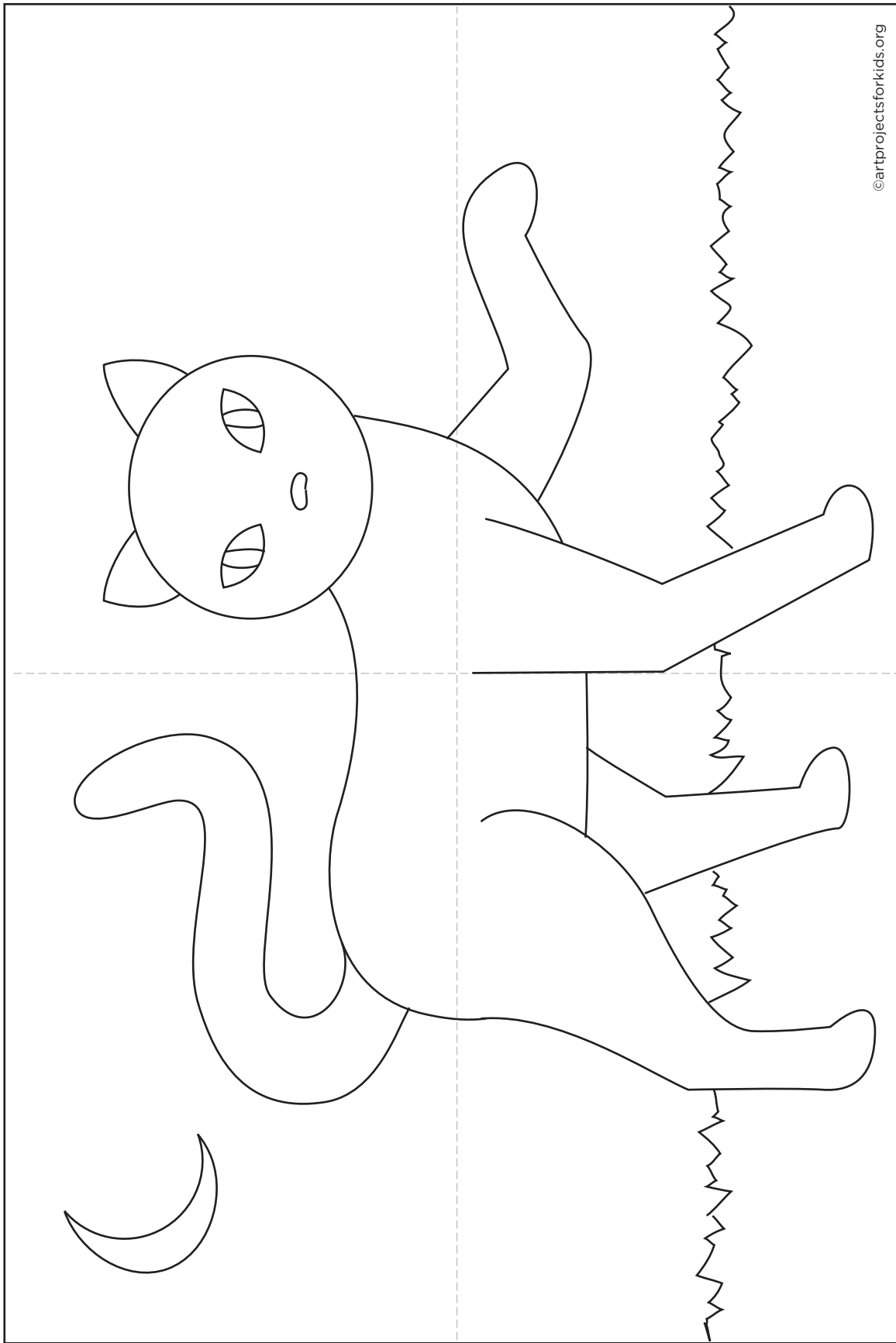

Broom and Leaves



Broom and Leaves

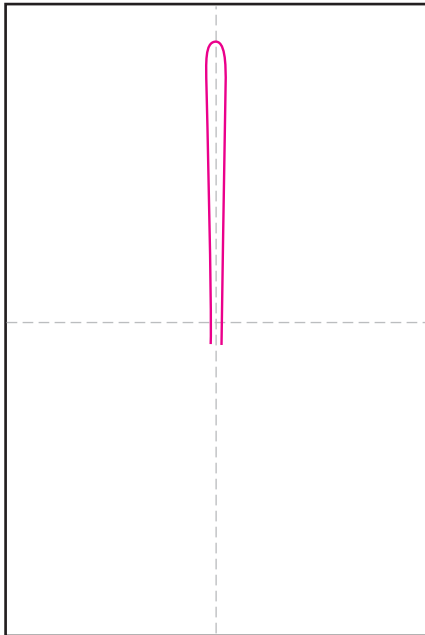

1. Start with the top of the handle. Draw it centered on the middle line.

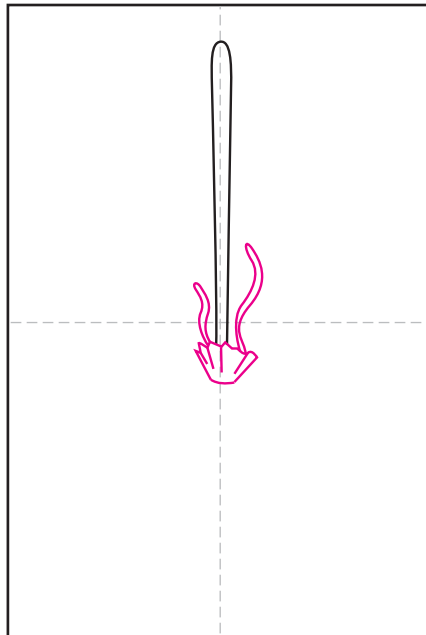

2. Add the top straw section of the broom. Include two ribbons.

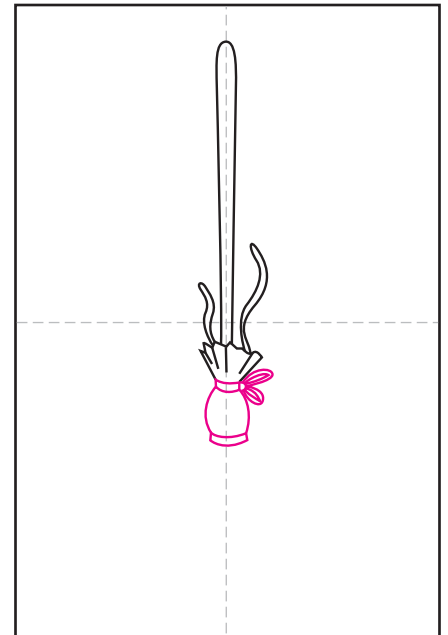

3. Draw the middle straw section of the broom. Add a bow.

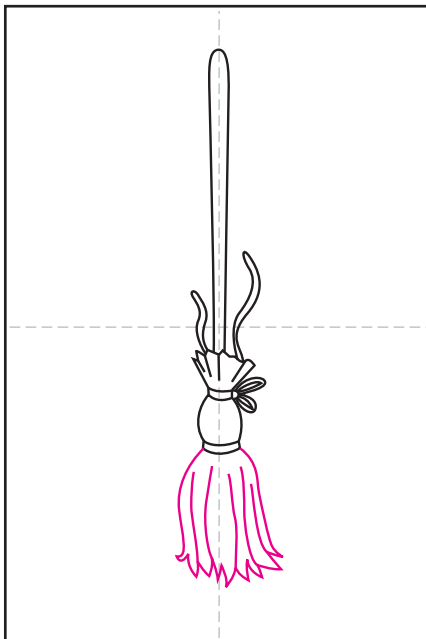

4. Draw the bottom straw section of the broom. Add lines to make it look like it is made from lots of straw.

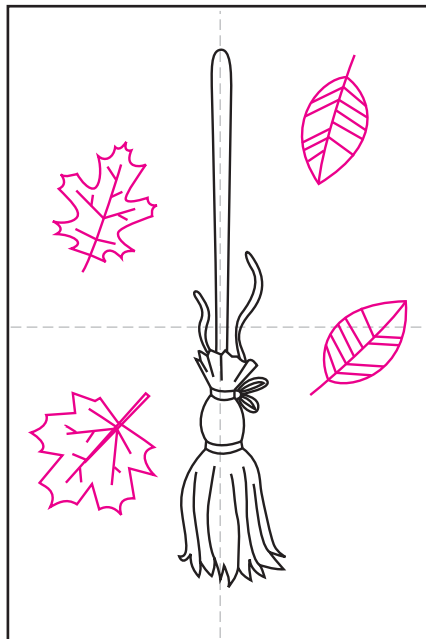

5. Finish with drawing some pretty fall leaves around the outside.



6. Trace the drawing with a black marker. Fill in carefully with your favorite markers.

Broom and Leaves

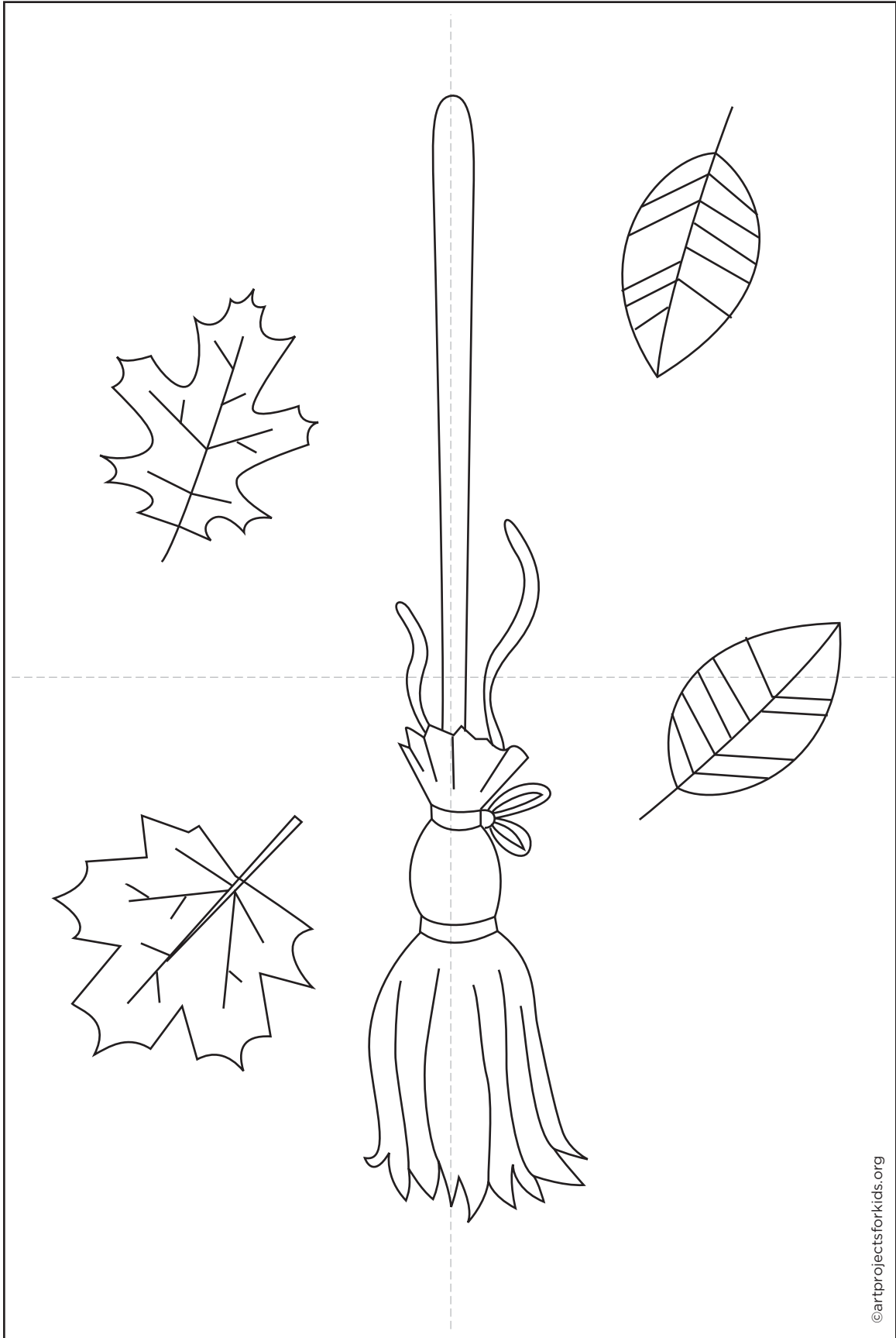

Halloween Candy



Halloween Candy

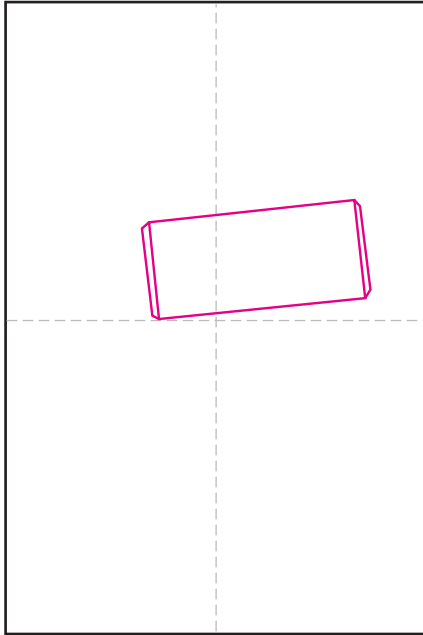

1. Start a chocolate bar with a rectangle with angled ends.

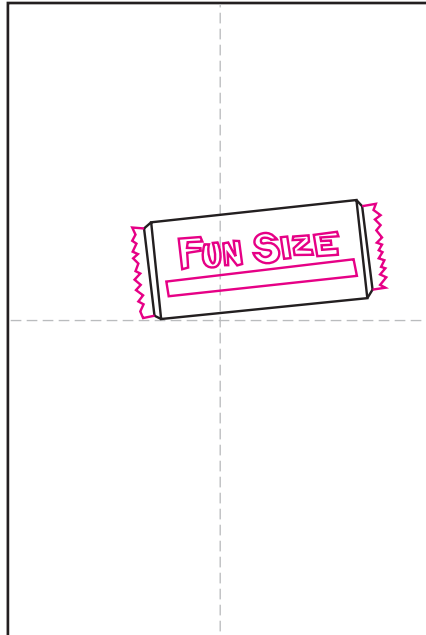

2. Add a zig zag ends on both short sides. Draw block letters "Fun Size" and a line below.

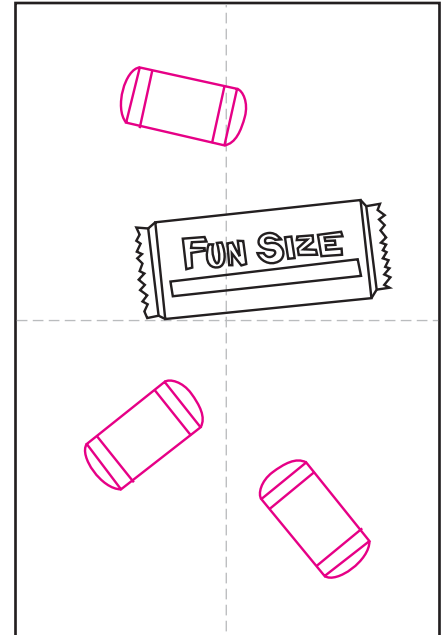

3. Draw three roll candies with wrapper lines inside.

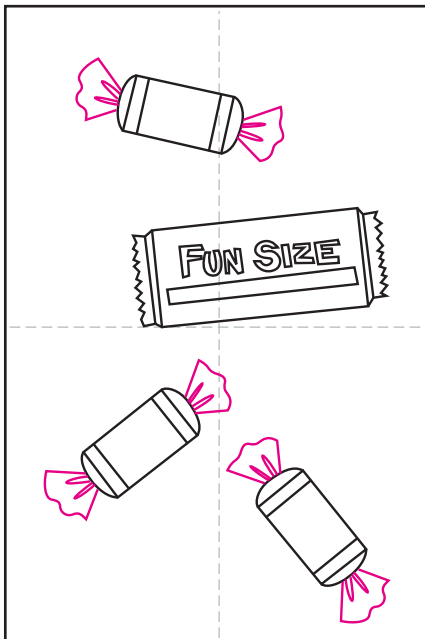

4. Add the twist ends to all the roll candies.

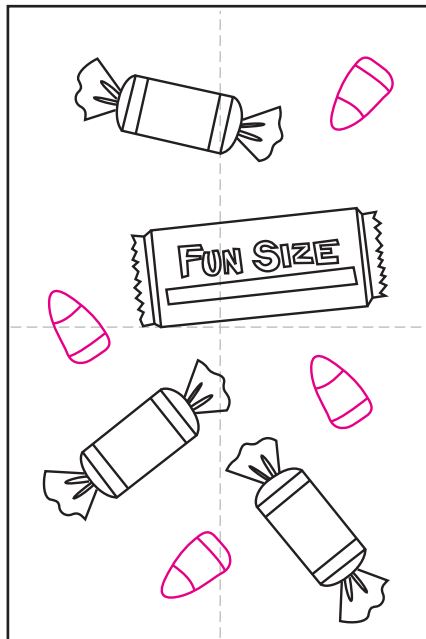

5. Finish by filling in with large candy corn shapes.



6. Trace the drawing with a black marker. Fill in carefully with your favorite markers.

Halloween Candy



Bubbly Cauldron

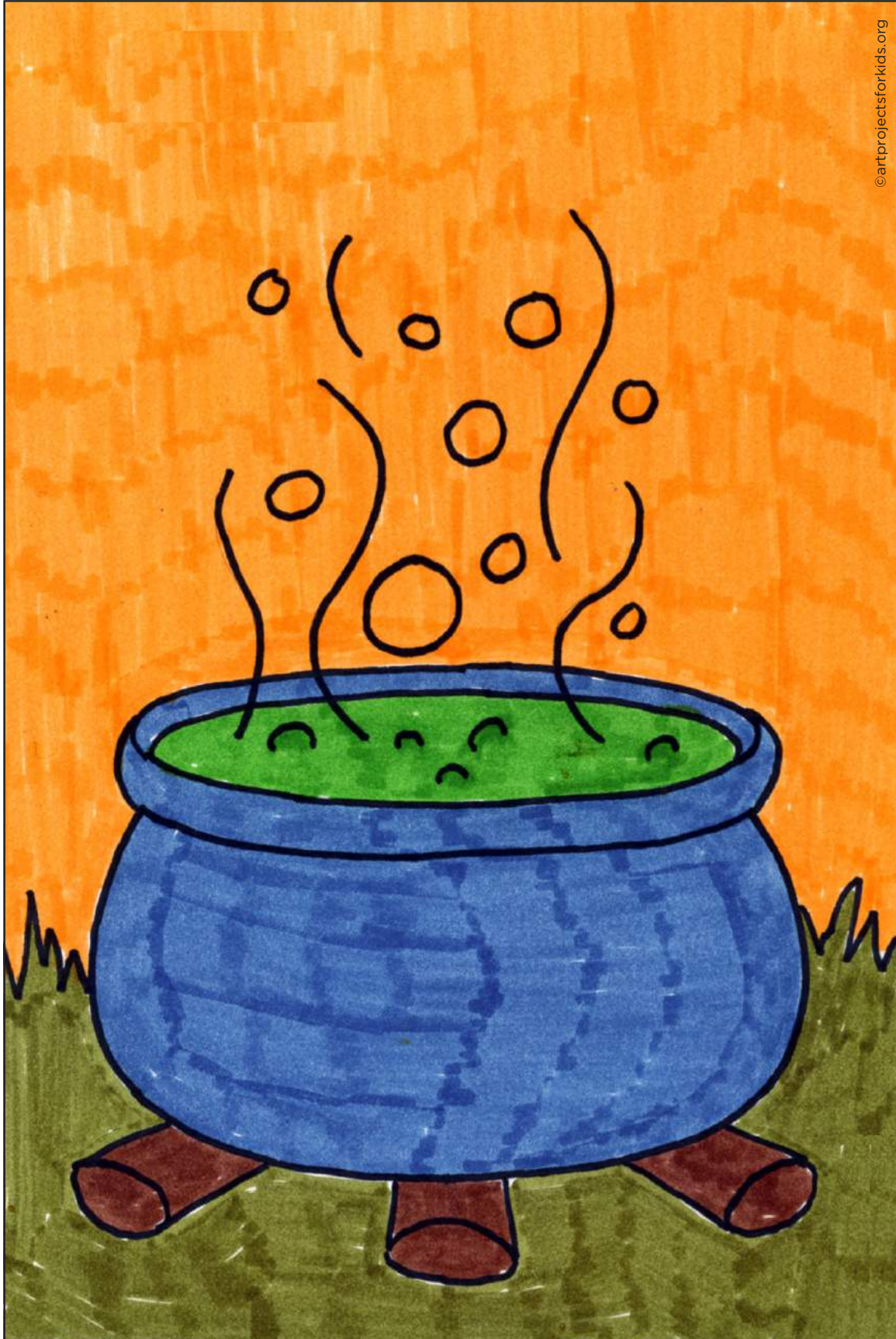

Bubbly Cauldron

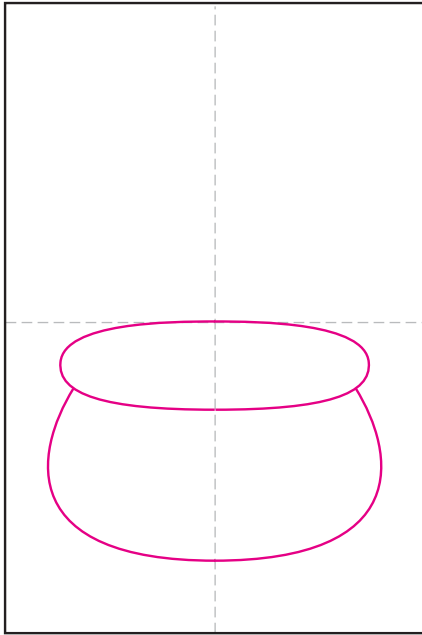

1. Draw a wide U and an oval on the top for the rim.

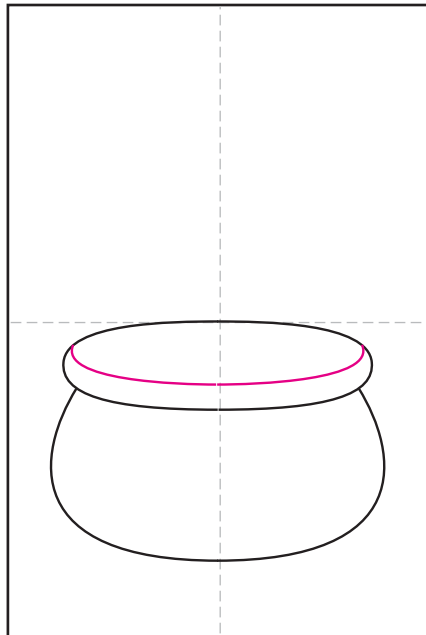

2. Add a curved edge for the inside of the rim.

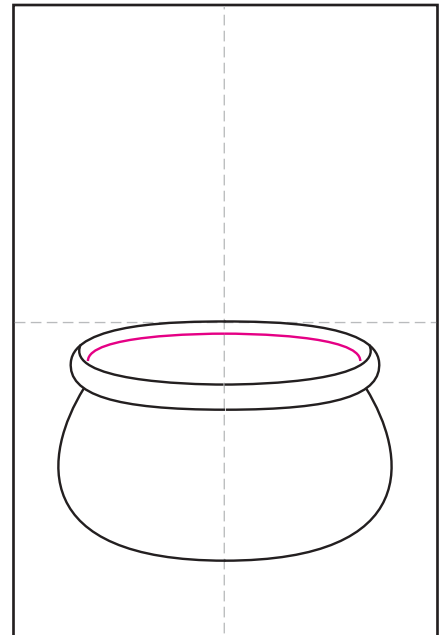

3. Draw another curved line for the edge of the liquid.

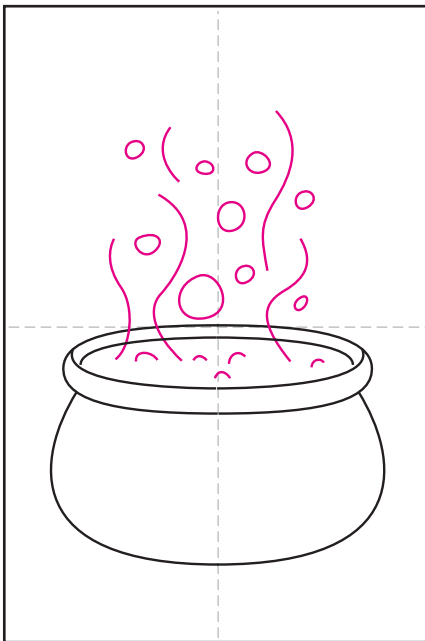

4. Draw the bubbles and swirls that are flowing up from the pot.

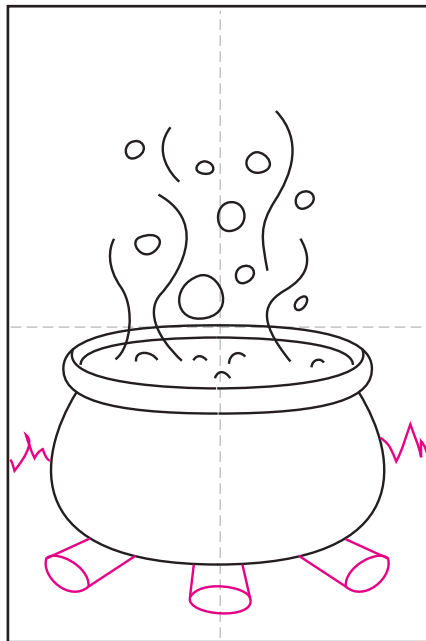

5. Add logs below and a grass line.



6. Trace the drawing with a black marker. Fill in carefully with your favorite colors.

Bubbly Cauldron

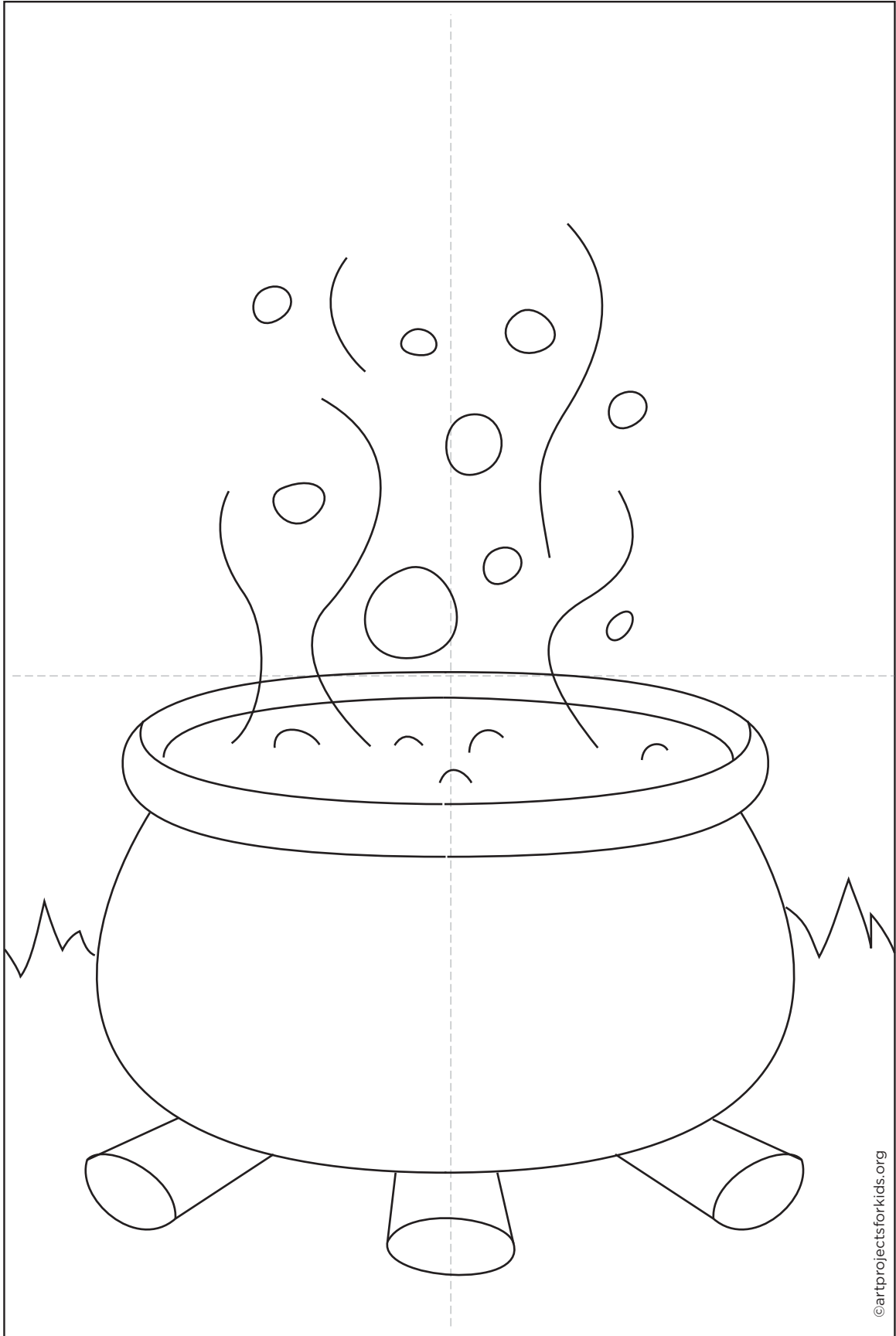

Fairy Costume



Fairy Costume

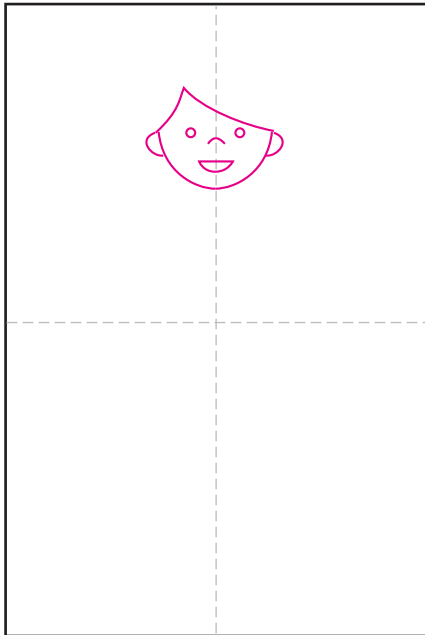

1. Draw the head and the hair line.

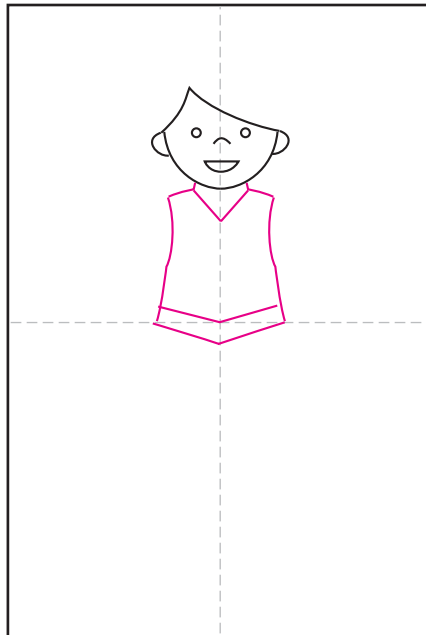

2. Start the top of the dress.

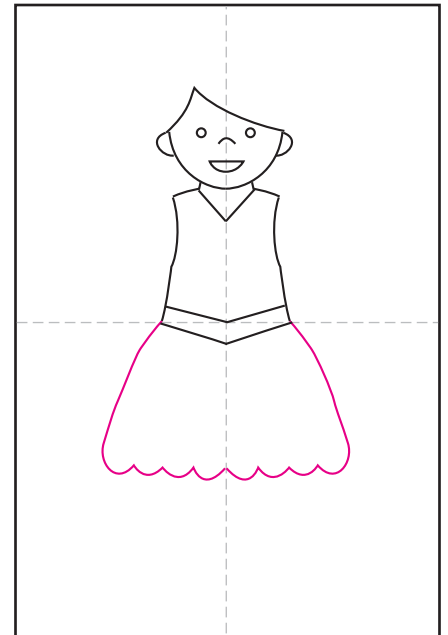

3. Finish the bottom of the dress with a fancy skirt and scallop hem.

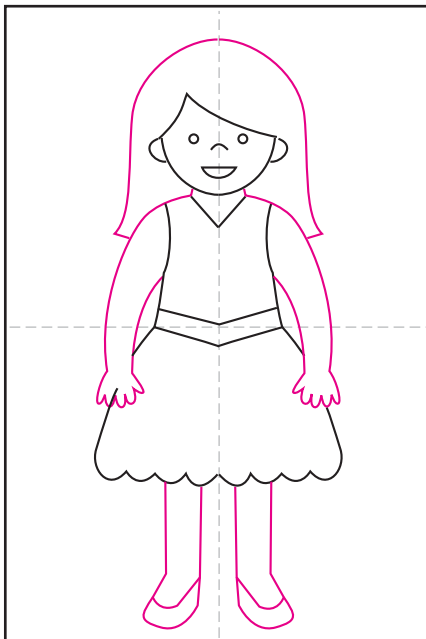

4. Add the legs, arms, and finish the hair. You can draw it any way you want.

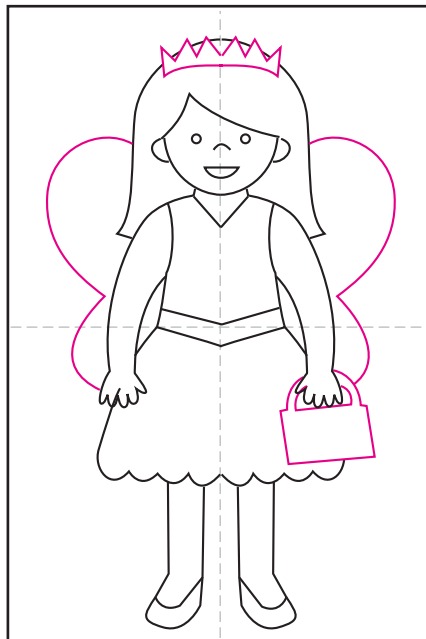

5. Add wings in the back, a crown, and a pail to hold the candy.



6. Trace the drawing with a black marker. Fill in carefully with your favorite colors.

Fairy Costume

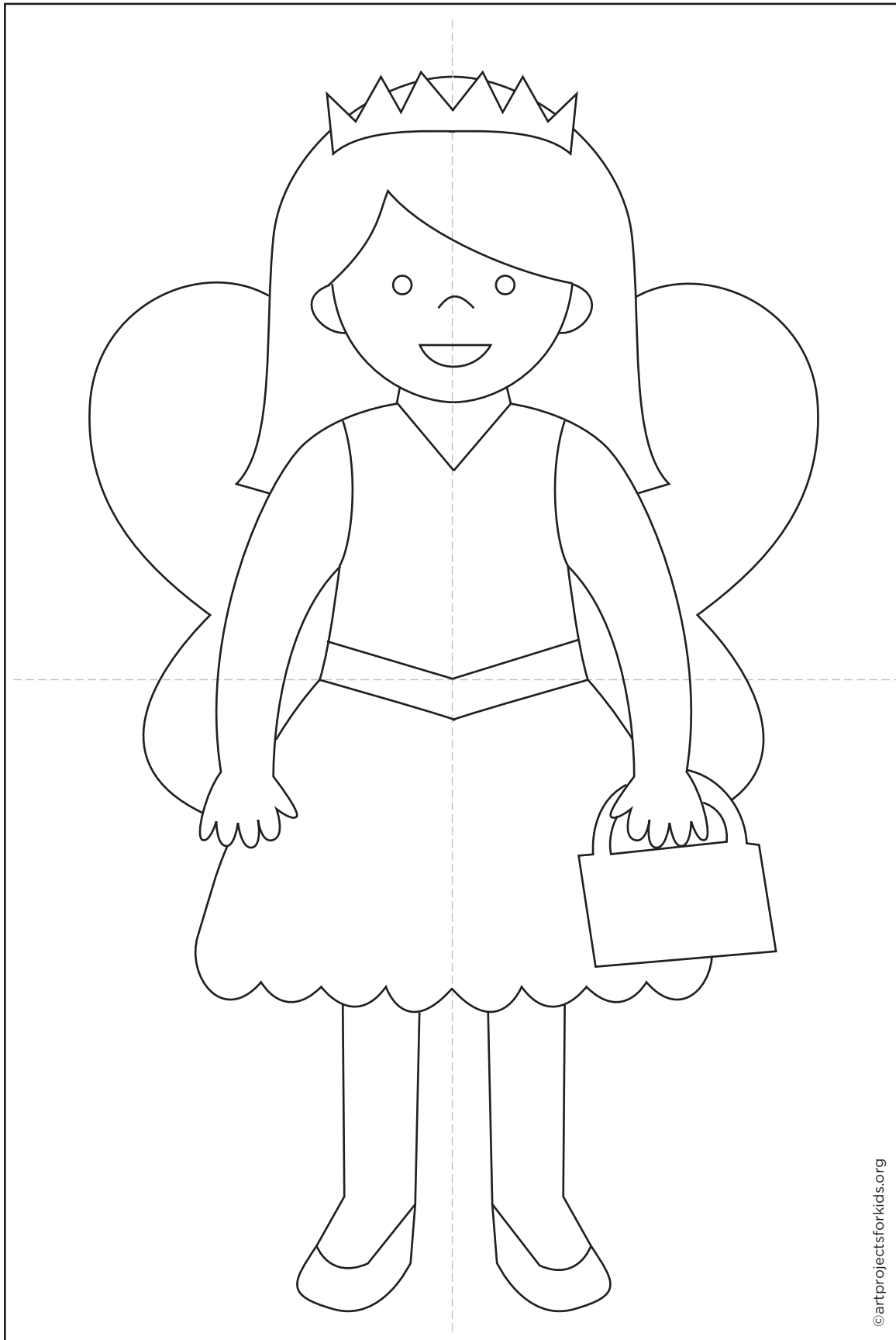

Frankenstein Costume



Frankenstein Costume

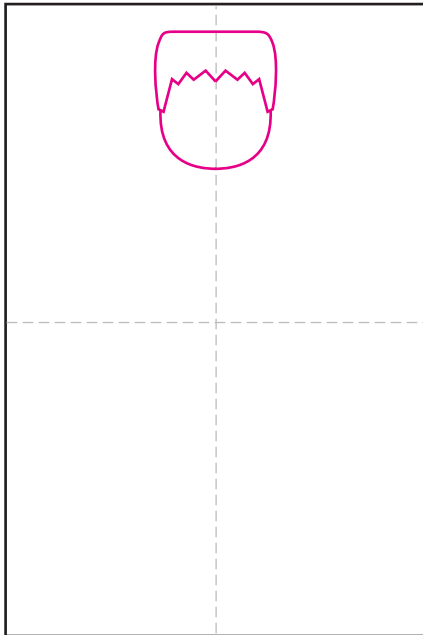

1. Draw the head with hair, centered on the middle line.

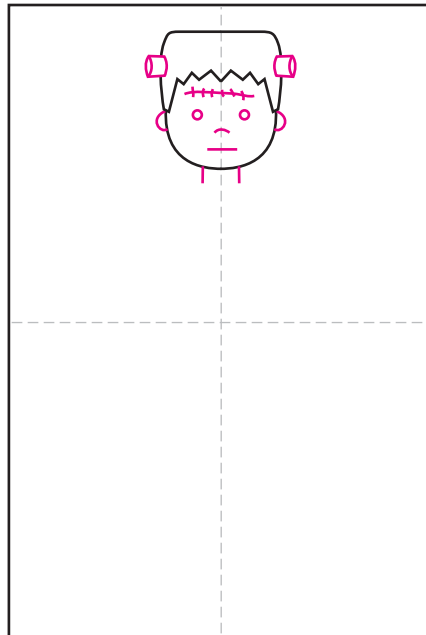

2. Add the face, neck and ears, along with bolts coming out of the temple.

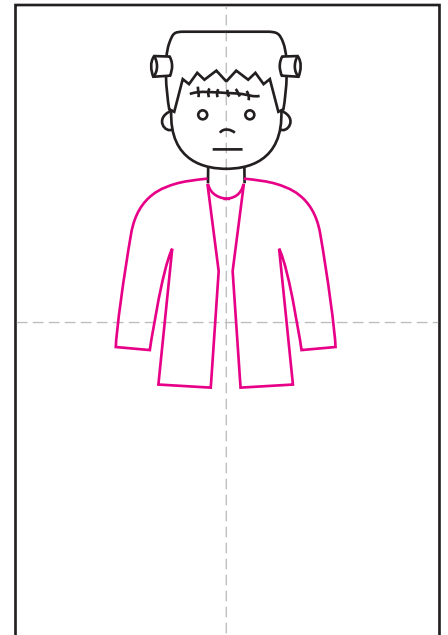

3. Draw a suit coat, centered on the middle line.

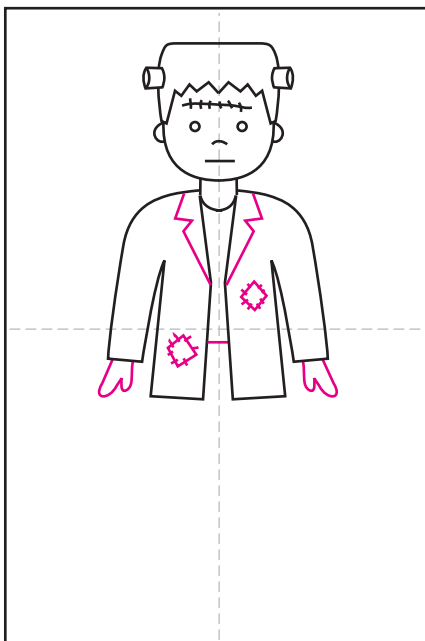

4. Add the hands and suit lapel, and some patches.

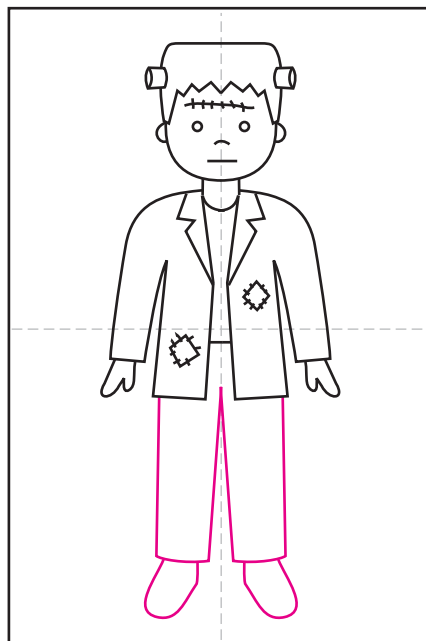

5. Finish with drawing two symmetrical pant legs, and two thick boots.



6. Trace the drawing with a black marker. Fill in carefully with your favorite markers.

Frankenstein Costume

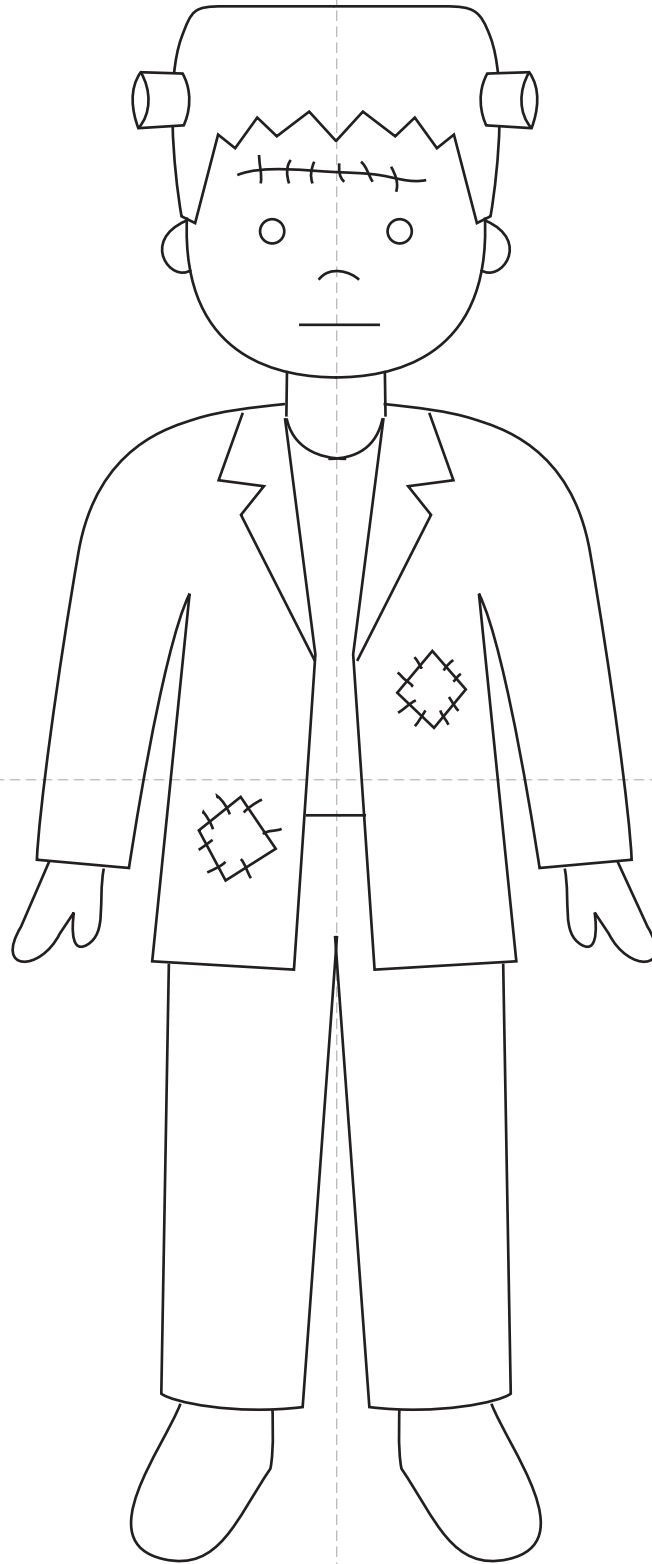

Scary Ghost



Scary Ghost



1. Draw the sides and top of the ghost body.

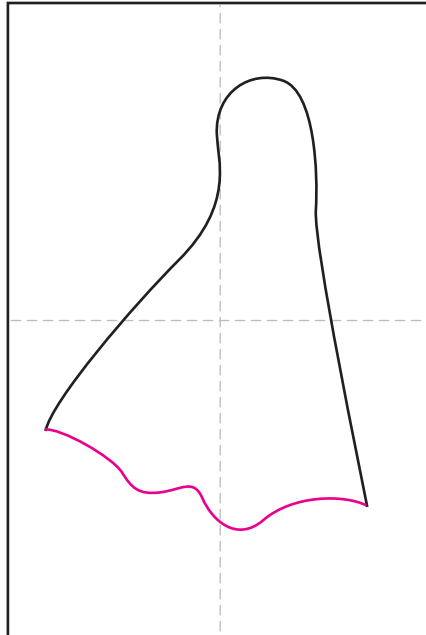

2. Connect then with a curvy bottom edge.

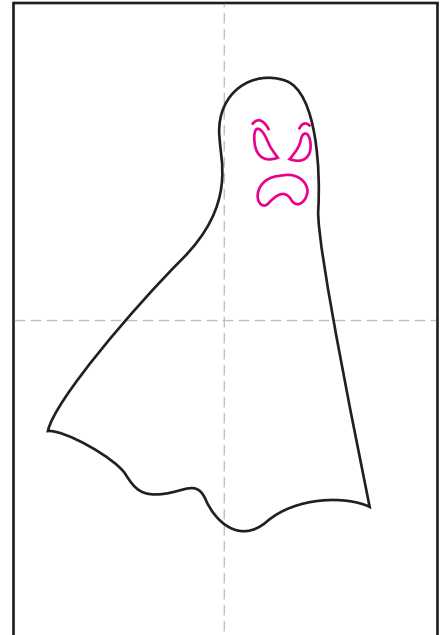

3. Draw an angry face. Try making it off to one side so your ghost has more dimension.

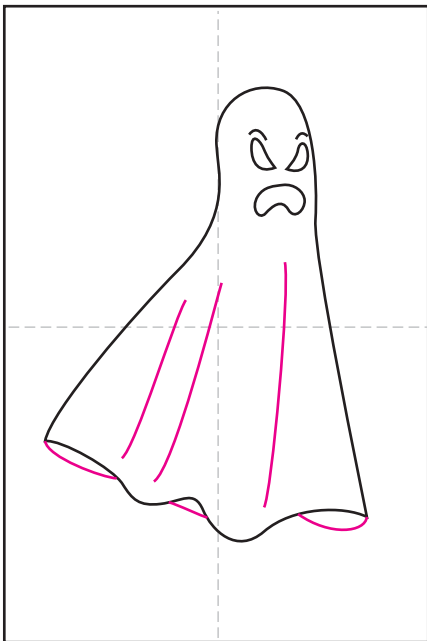

4. Finish the bottom edge, and add some fold lines.

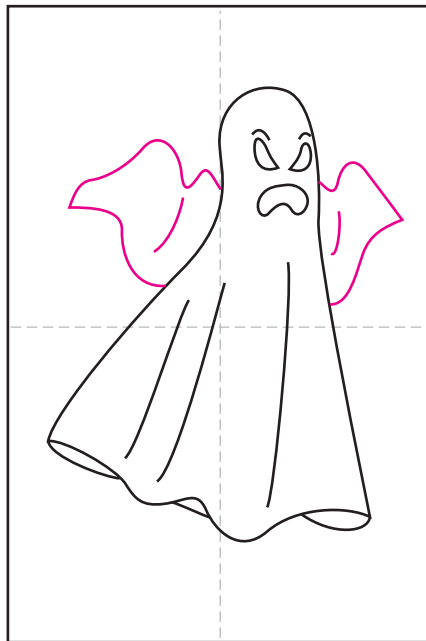

5. Draw two floppy arms, with more fold lines inside.



6. Trace the drawing with a black marker. Fill in the background with your favorite color.

Scary Ghost



Haunted House



Haunted House

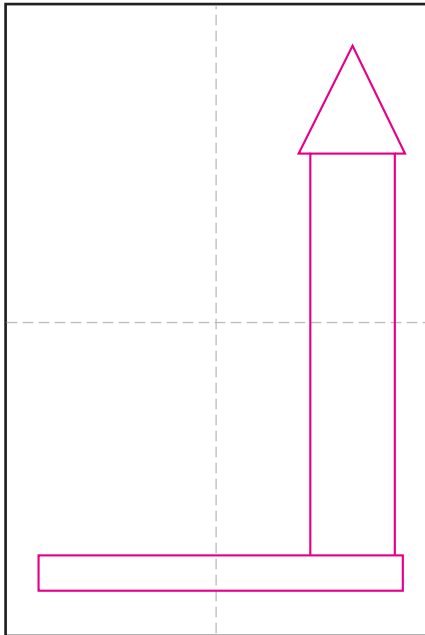

1. Draw a rectangle bottom base, and a skinny tower shape on the right side.

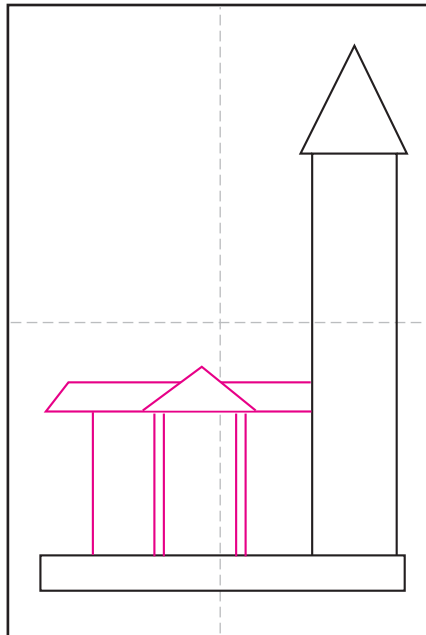

2. Draw the first floor with pillars for front door.

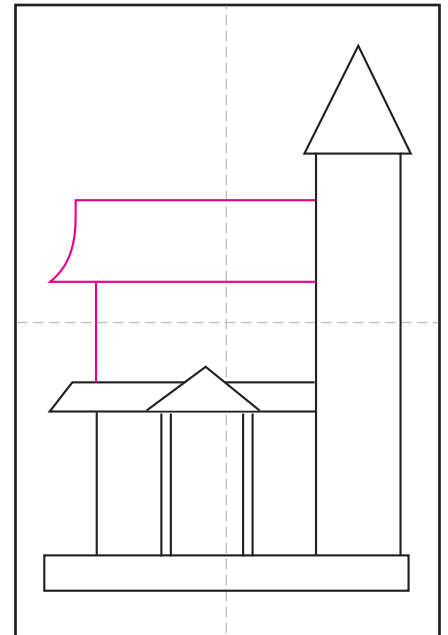

3. Add the second story wall and roof.

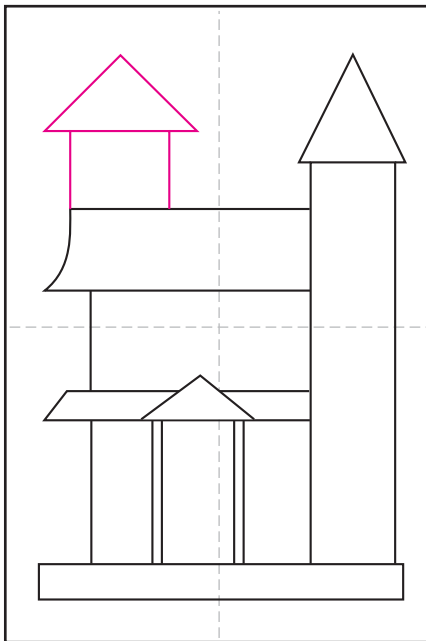

4. Add the small third story tower.

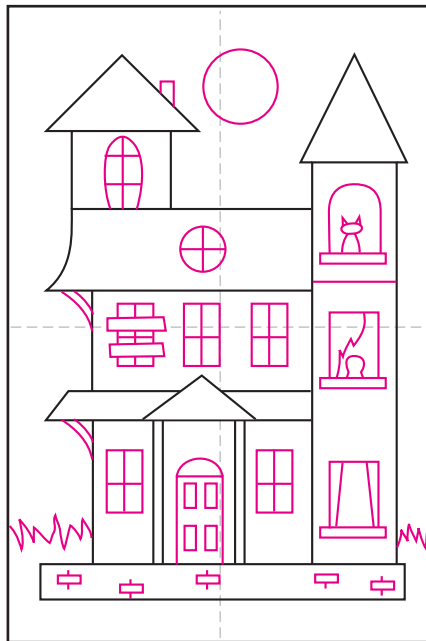

5. Have fun adding all the windows and doors as shown. Finish with a grass line and full moon in the sky.



6. Trace the drawing with a black marker. Fill in carefully with your favorite colors.

Haunted House

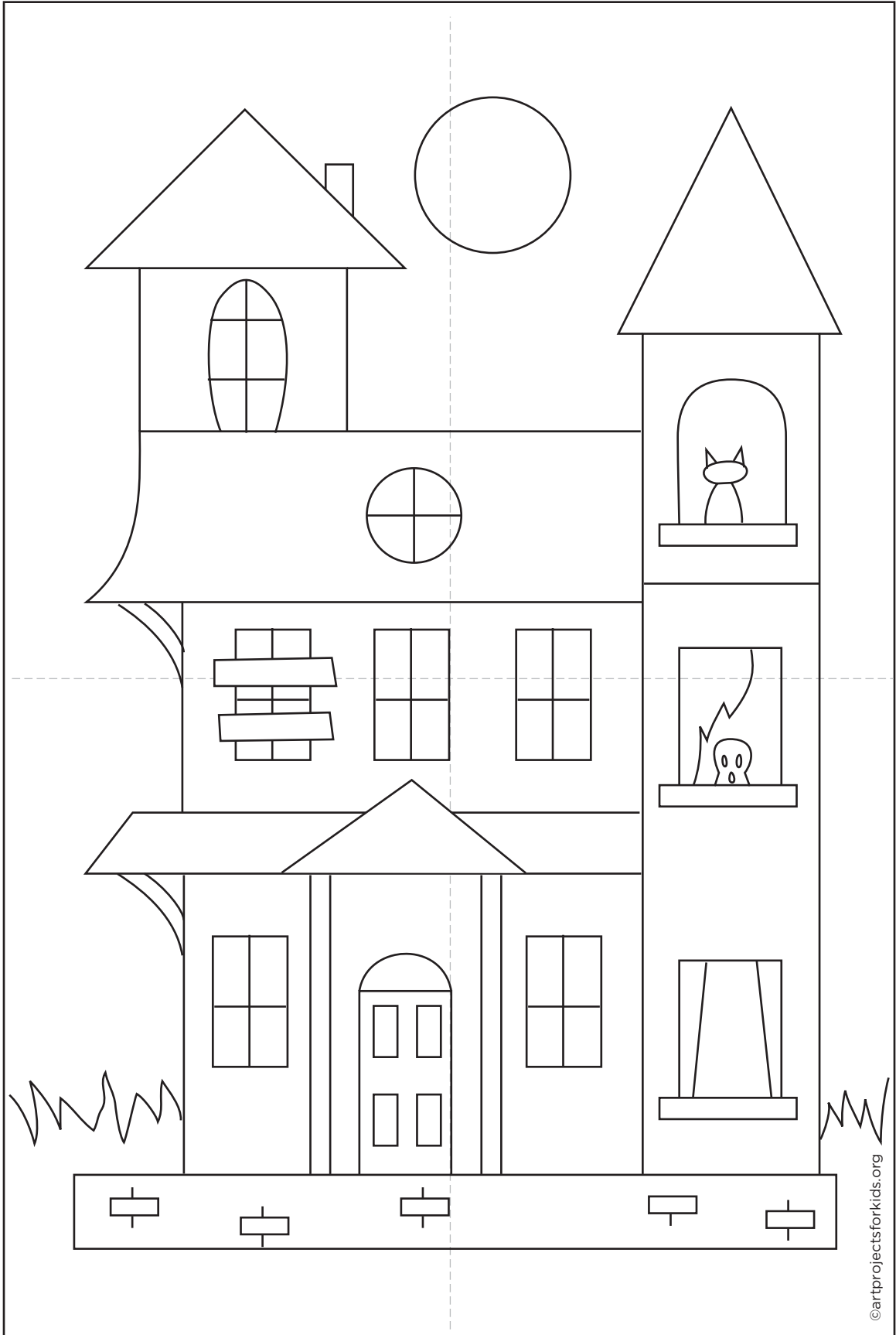

Maple Leaf



Maple Leaf

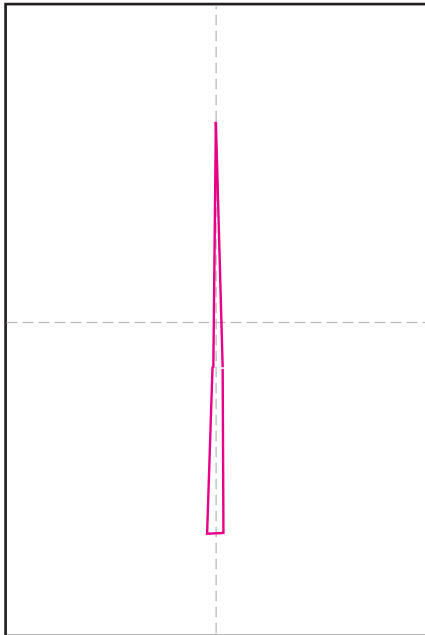

1. Draw the center stem.

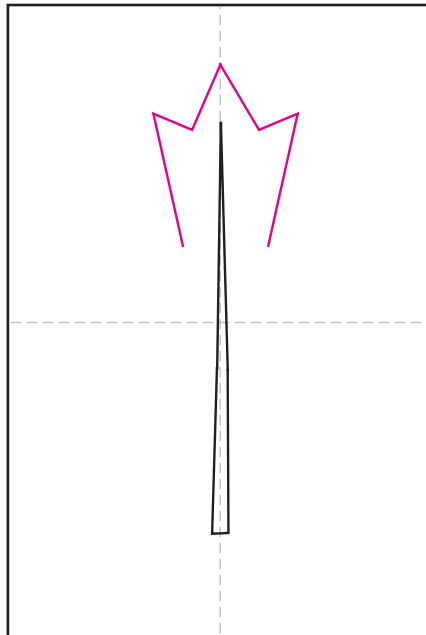

2. Start the top of the leaf, centering the shape above the stem.

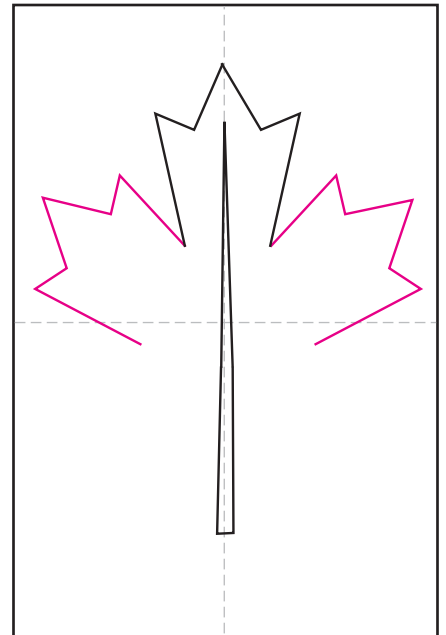

3. Draw the same shape on the left and on the right. Try to make them symmetrical.

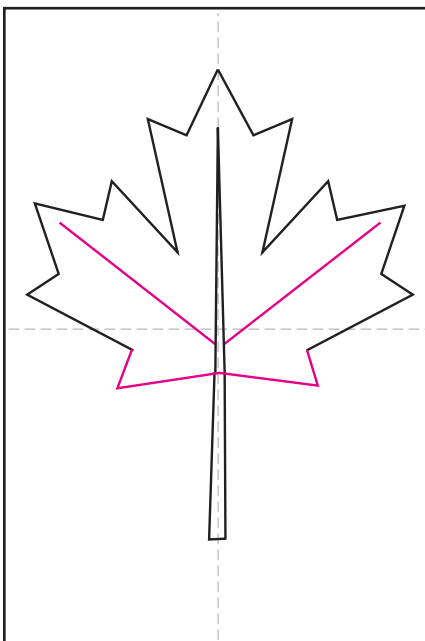

4. Finish the bottom of the leaf on both sides. Add the main center vein lines.

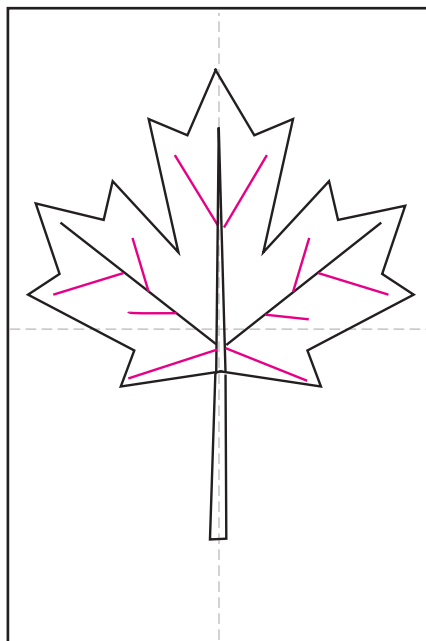

5. Finish with more vein lines.



6. Trace the drawing with a black marker. Fill in carefully with your favorite markers.

Maple Leaf

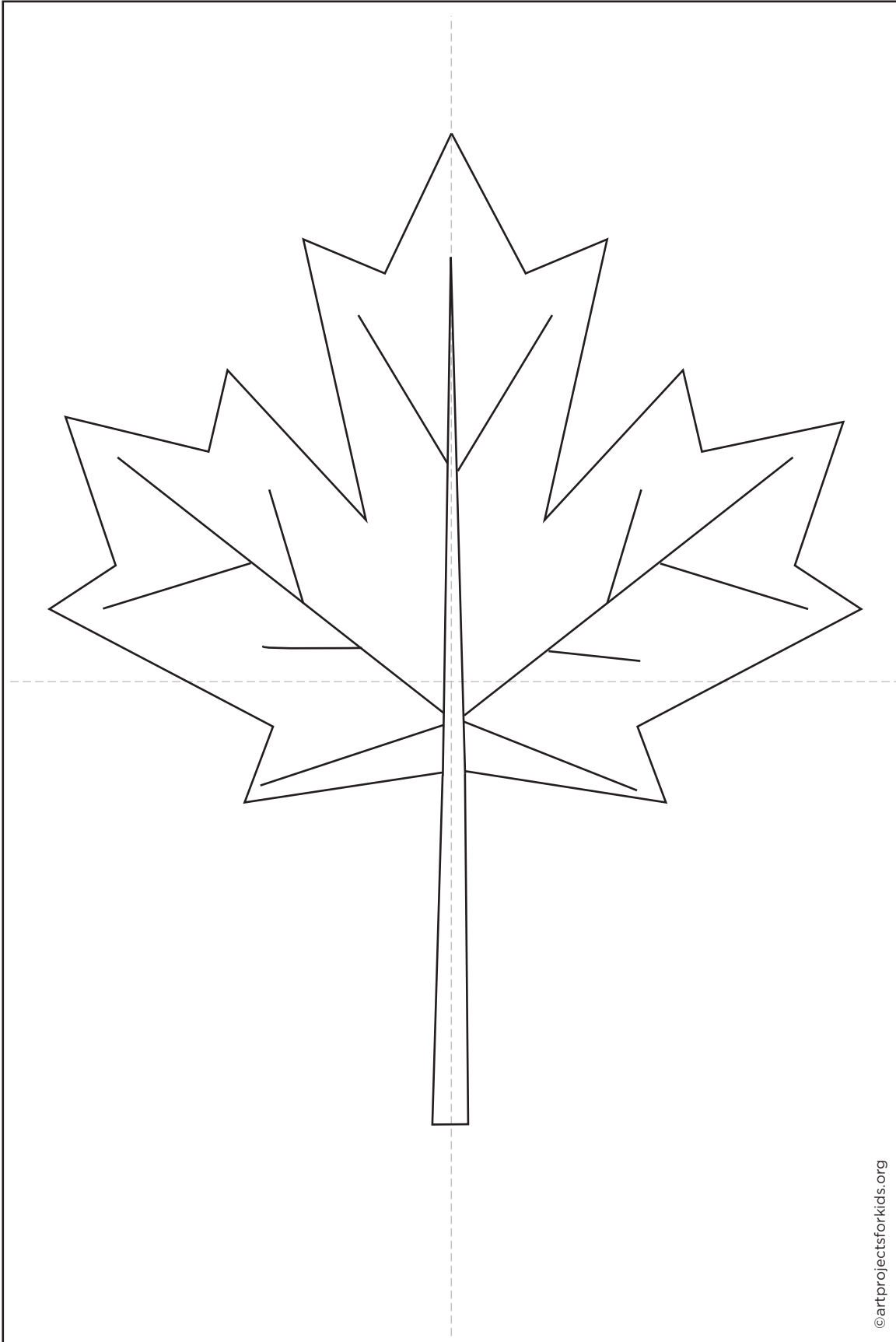

Owl Face



Owl Face

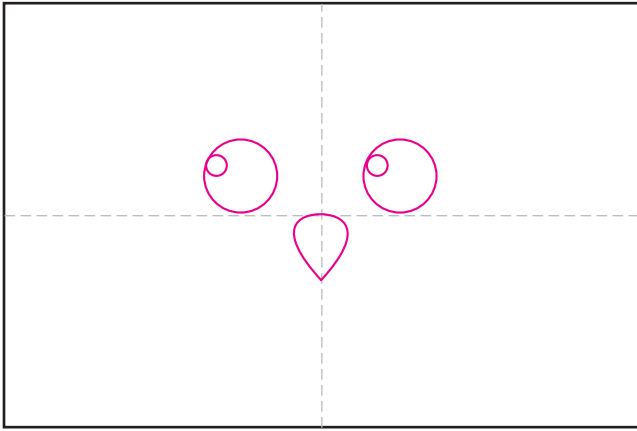

1. Draw the center beak. Add two large circles with smaller "dots" inside. (They are to stay white.)

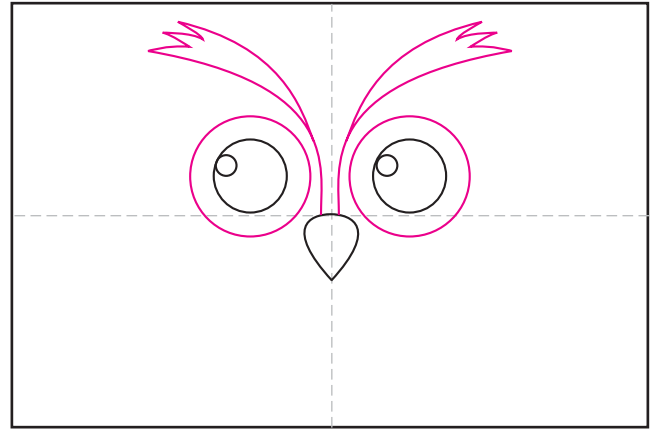

2. Draw rings around each eye. Draw two matching and symmetrical brows.

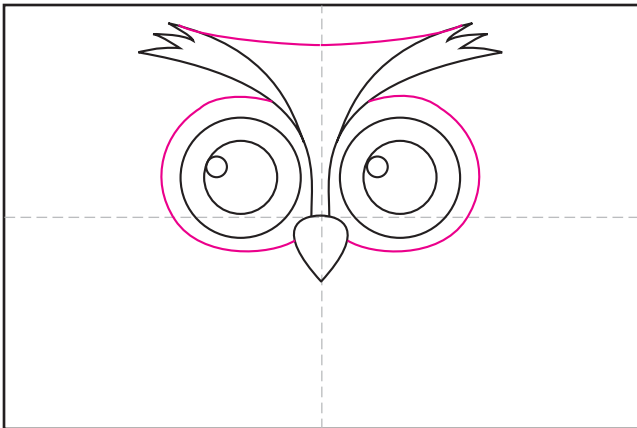

3. Add another ring around the eyes, and connect the brows on top.

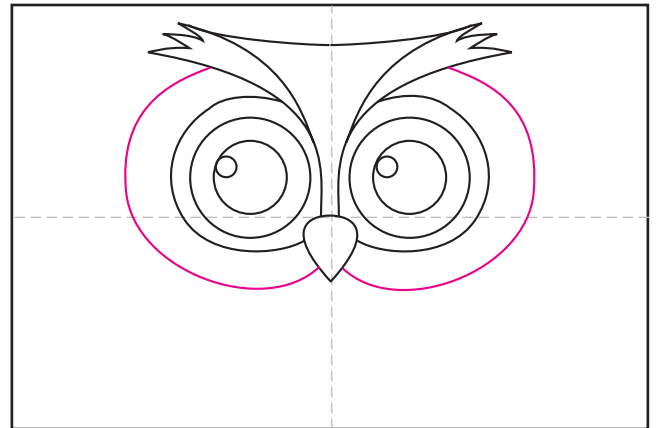

4. Complete the face with two curved cheeks.

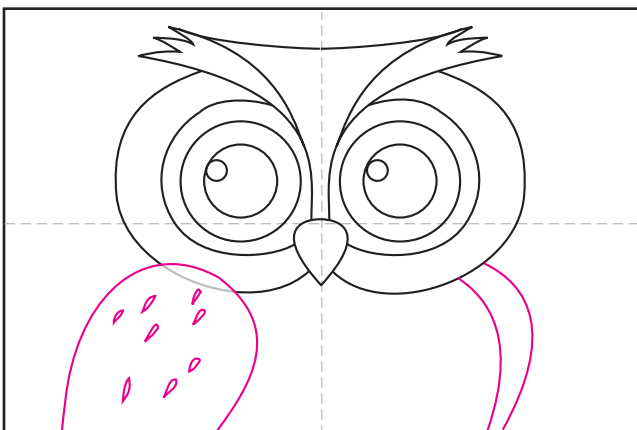

5. Draw the left wing that overlaps a cheek, and another that is tucked behind.



6. Trace the drawing with a black marker. Fill in carefully with your favorite colors and add layers to create shadows.

Owl Face

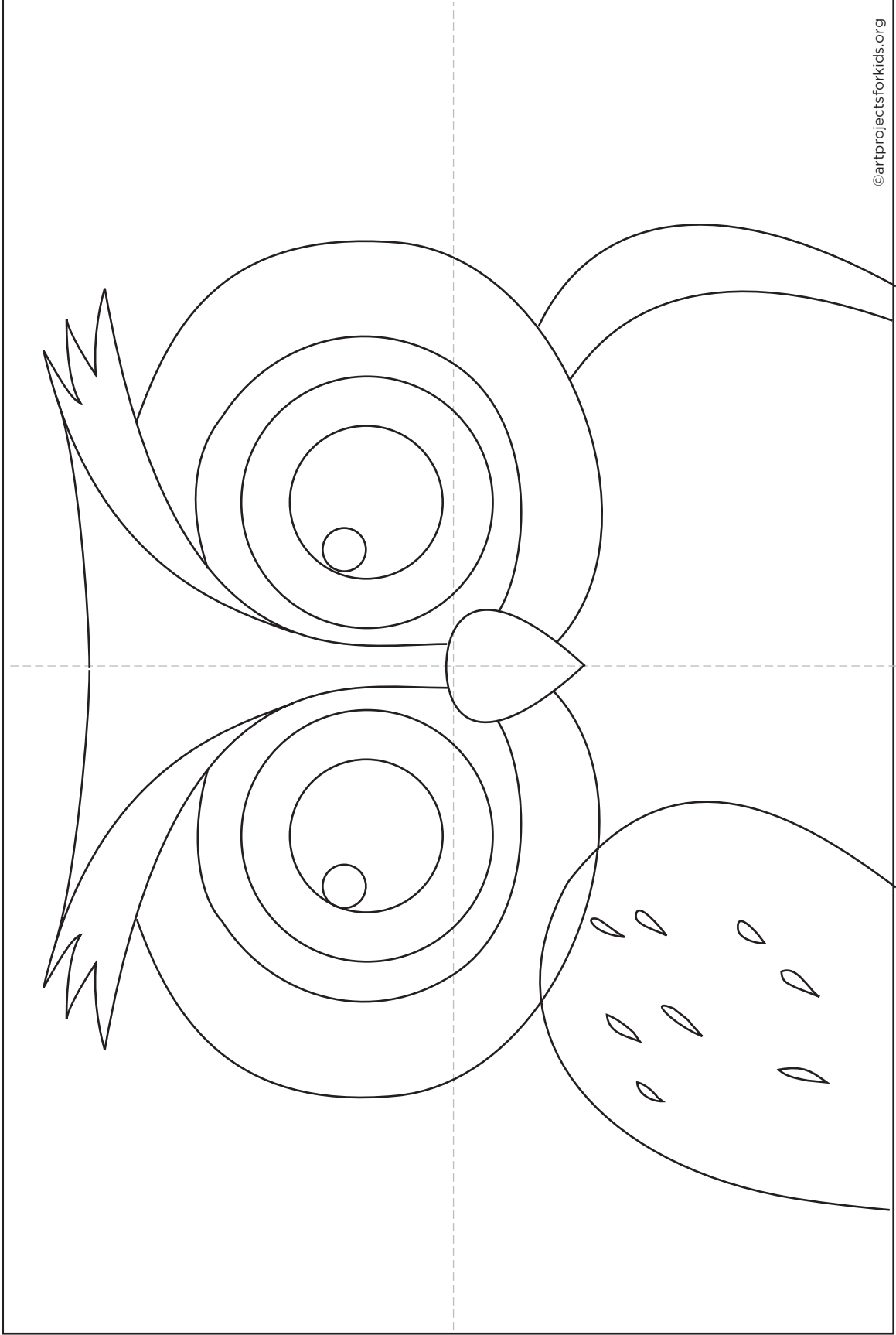

Owl in a Tree



Owl in a Tree

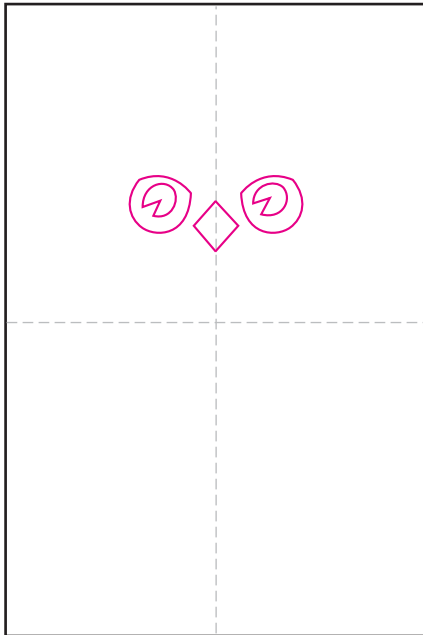

1. Start with drawing the beak. Add two symmetrical eyes.

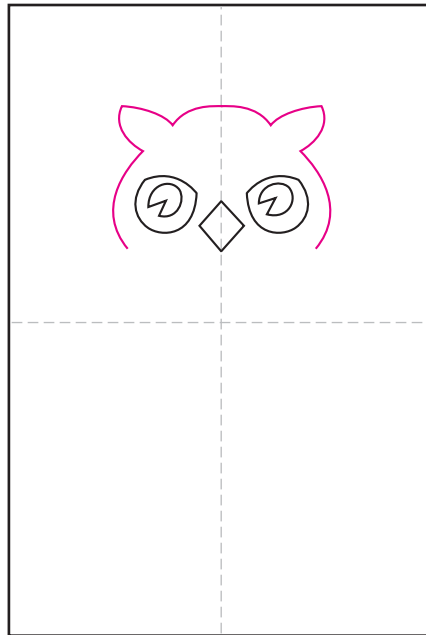

2. Draw the head and ears around the eyes and beak.

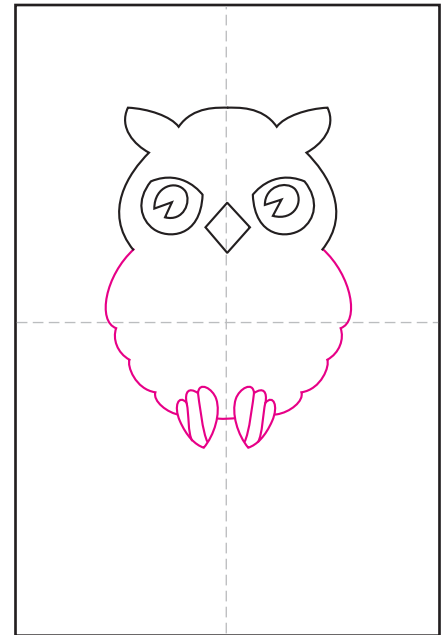

3. Add the symmetrical body below. Draw two claws at the bottom.

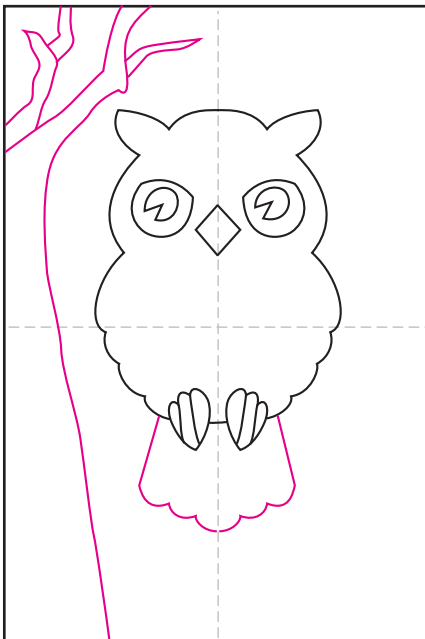

4. Draw a tail below the body. Start the tree that comes in from the left side of the paper.

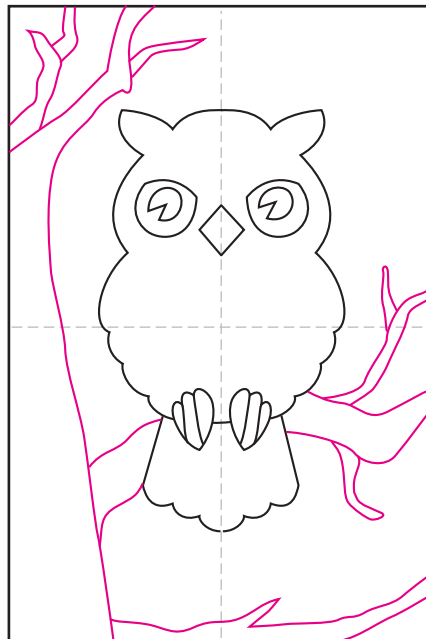

5. Add the two horizontal branches.



6. Trace the drawing with a black marker. Fill in carefully with your favorite colors (black for a silhouette!).

Owl in a Tree

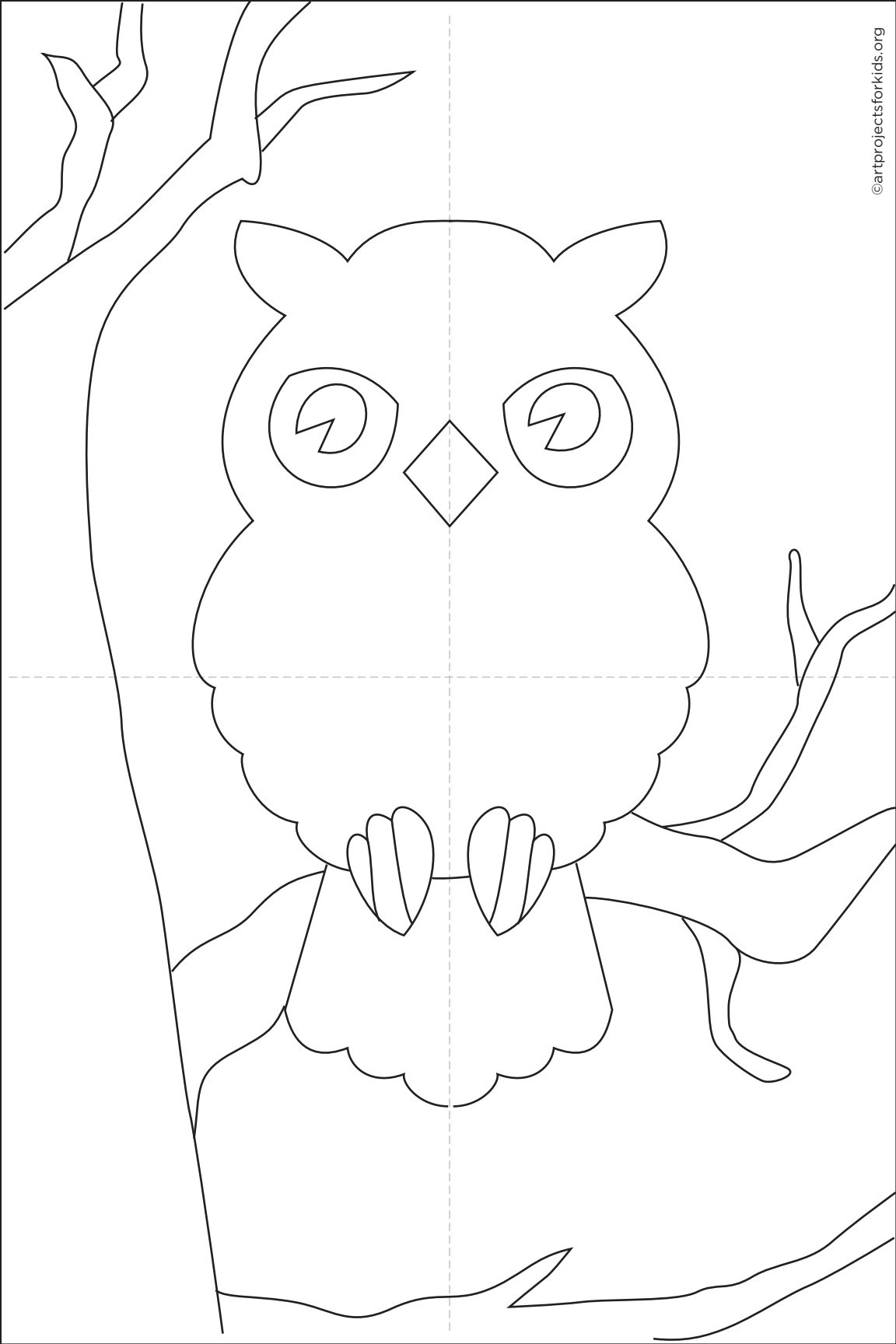

Pickup Truck and a Pumpkin



Pickup Truck and a Pumpkin

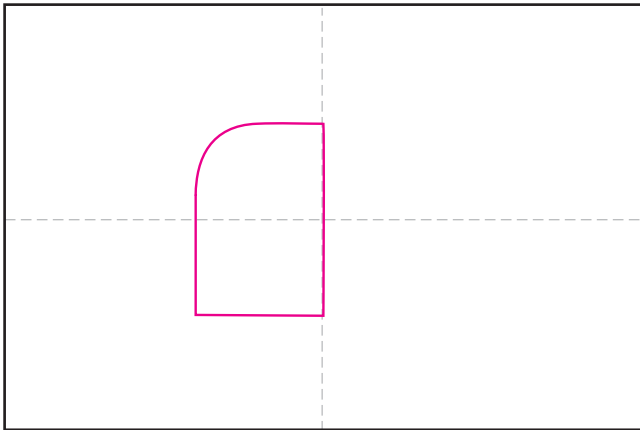

1. Draw a rectangle with a rounded corner to start the cab.

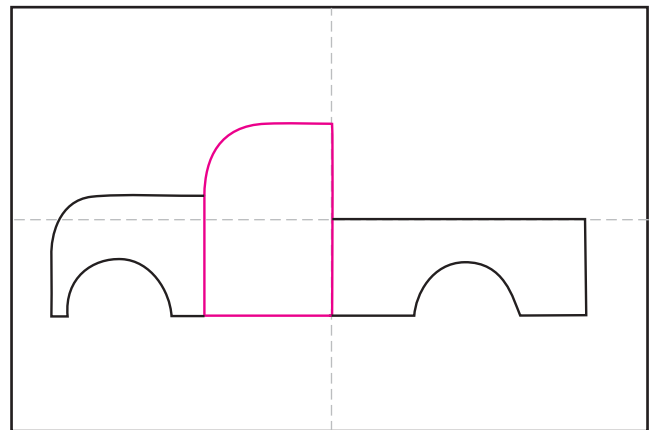

2. Add the front and back bed of the truck.

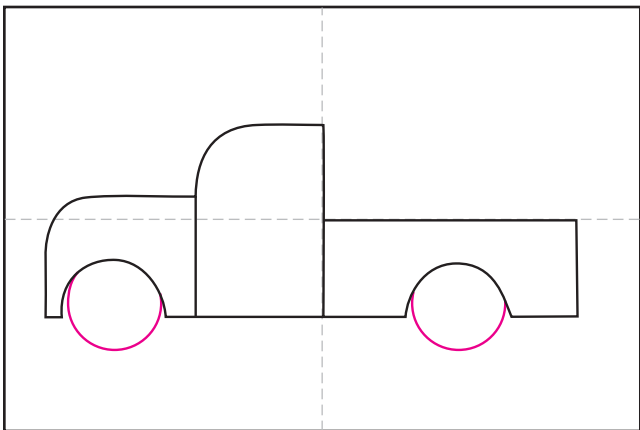

3. Draw rounded wheels that fit into the wells.

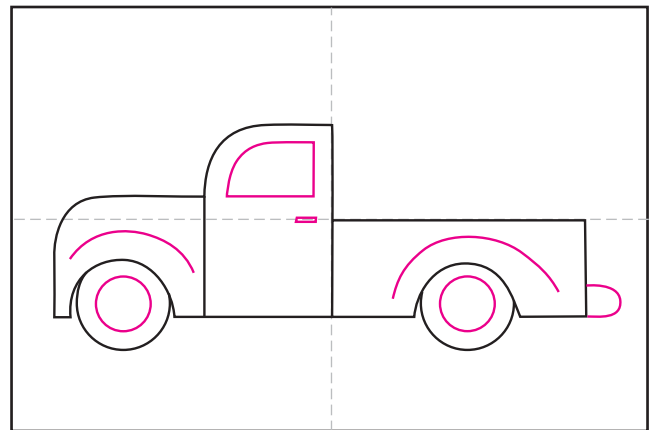

4. Add the hubcaps, and window and details.

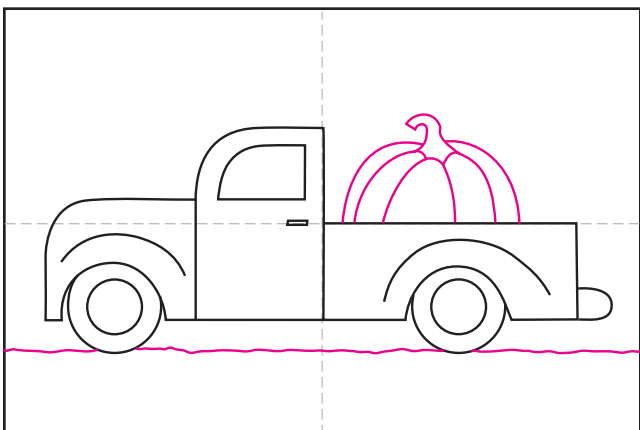

5. Draw a ground line. Add a large pumpkin in the bed of the truck.



6. Trace the drawing with a black marker. Fill in carefully with your favorite markers.

Pickup Truck and a Pumpkin

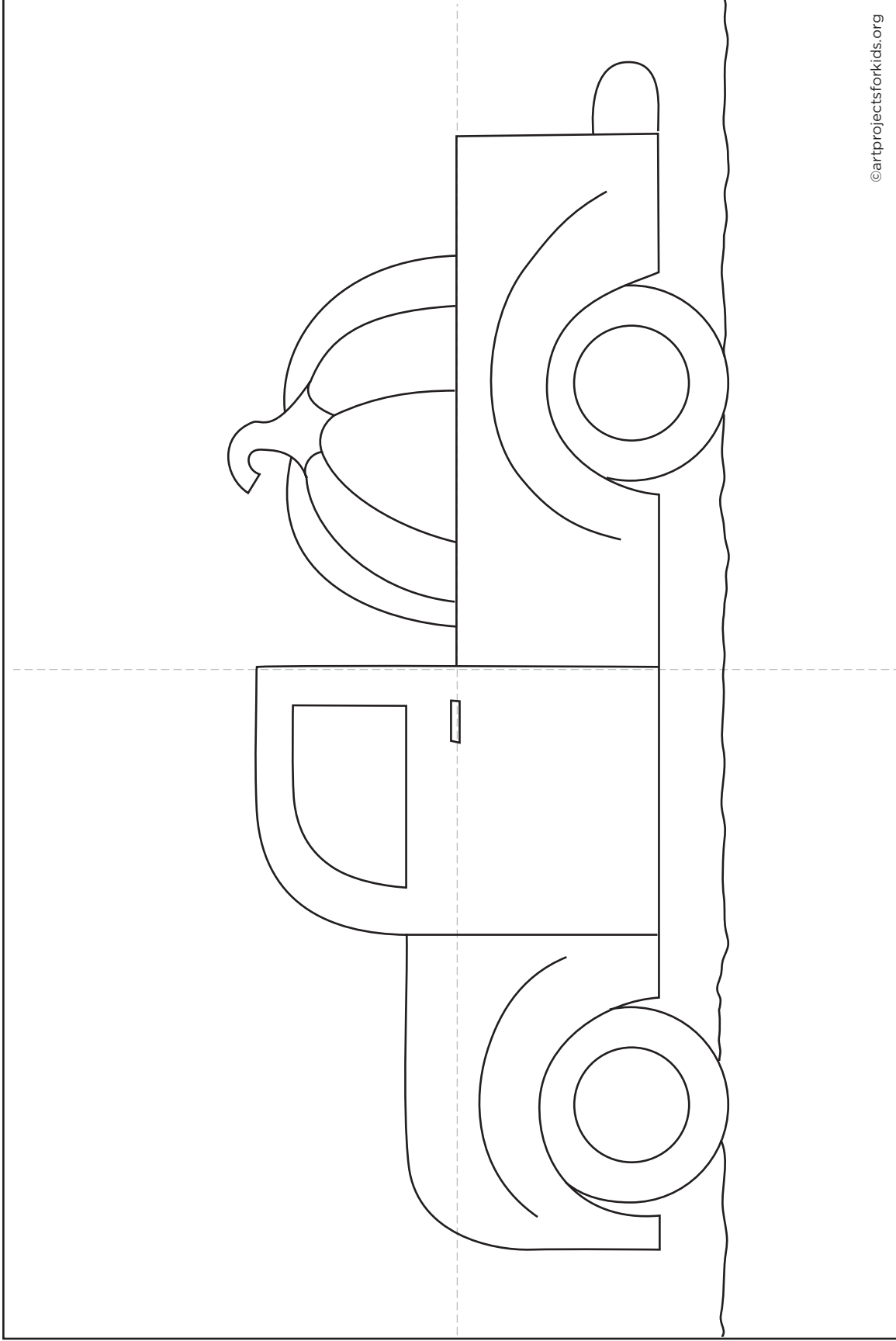

Carved Pumpkin



Carved Pumpkin

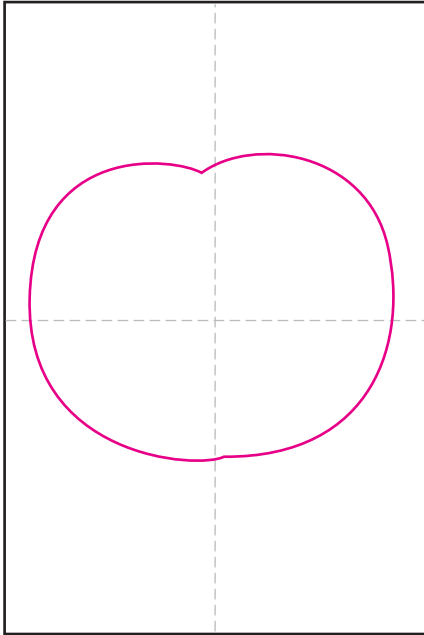

1. Draw a large circle shape with a dip on the top. Make sure it almost fills the width of the paper.

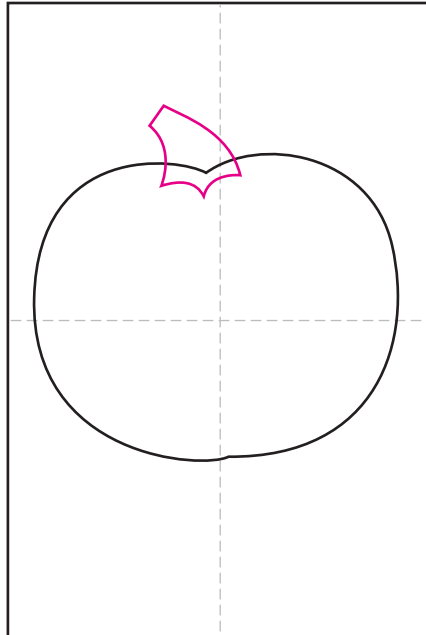

2. Add the top stem that has two curves on the bottom.

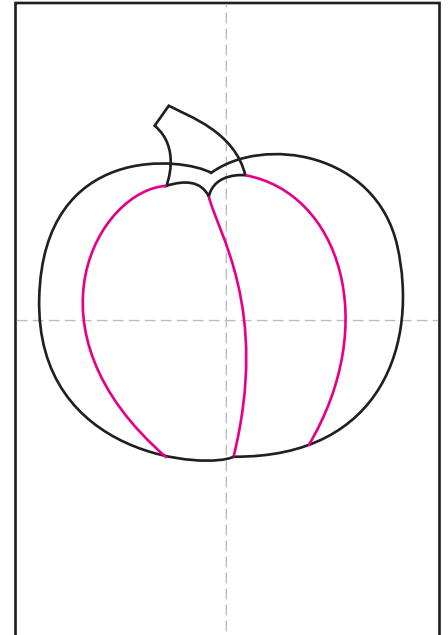

3. Starting at the bottom of the stem, draw three curved lines.

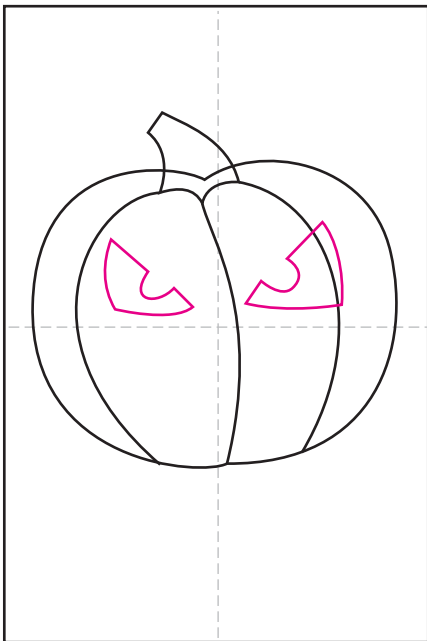

4. Draw two slanted angry eyes. If it helps, draw triangles and then add the eye shape.

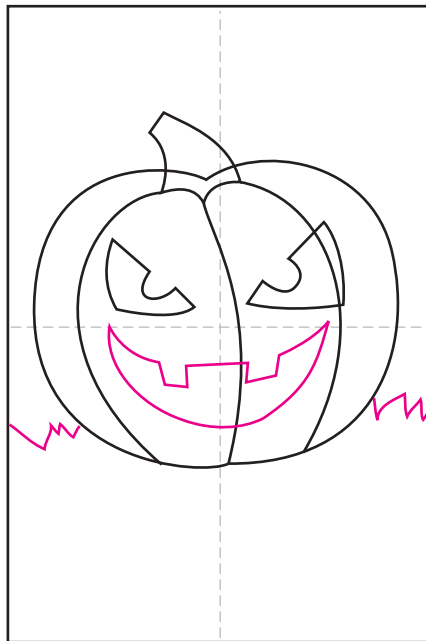

5. Draw a smiling mouth with two teeth. Finish with a grassy horizon line.



6. Trace the drawing with a black marker. Fill in carefully with your favorite markers.

Carved Pumpkin

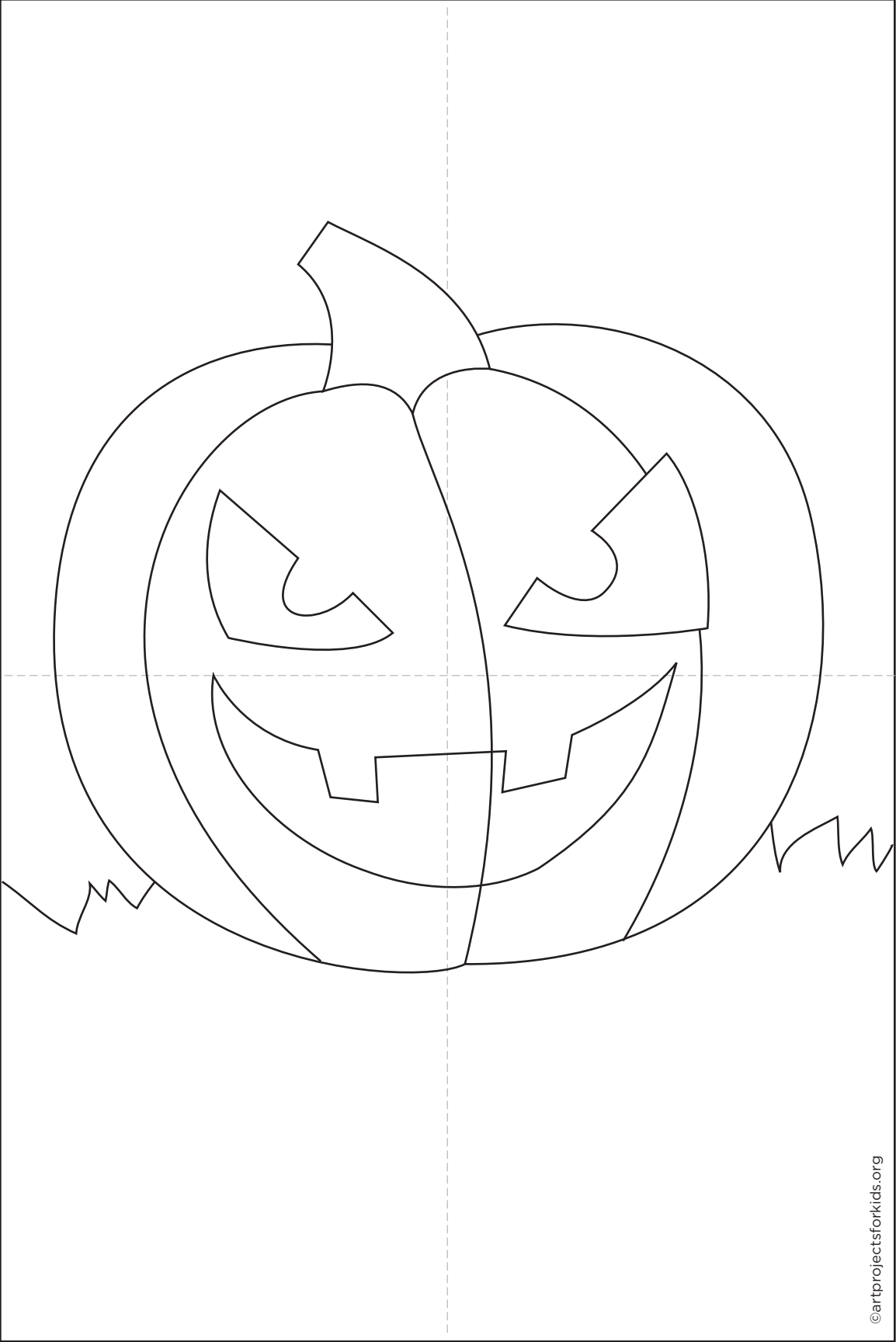

Scarecrow



Scarecrow

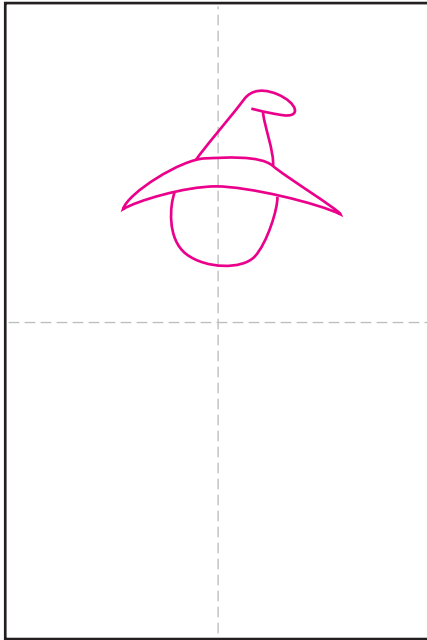

1. Draw the hat and the head.

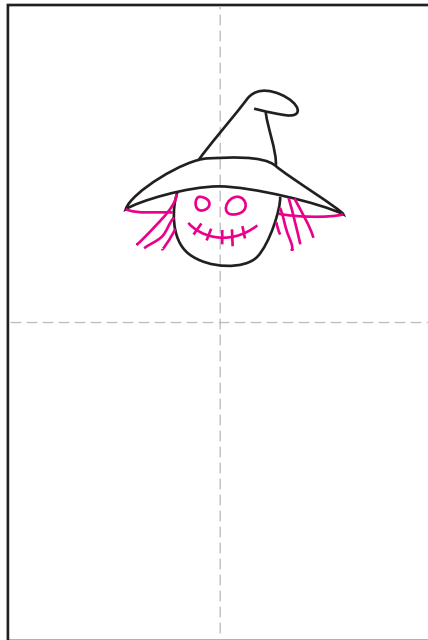

2. Add the hair and face.

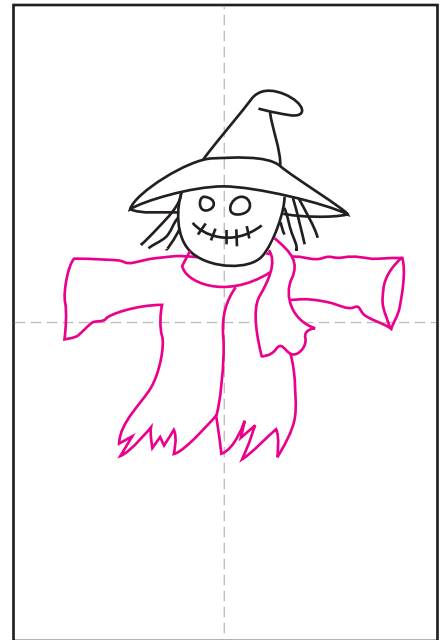

3. Draw a scarf below the head, and a torn shirt.

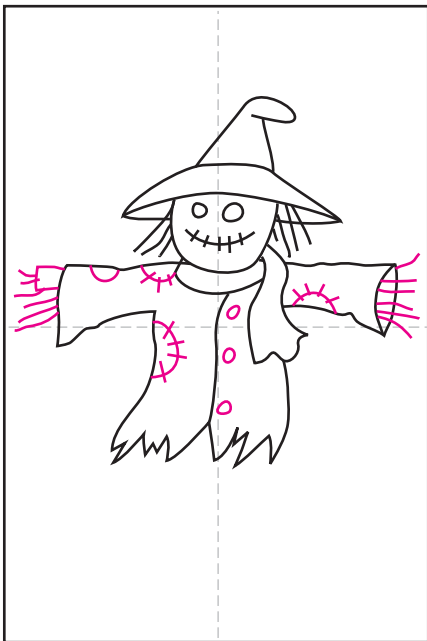

4. Add patches to the shirt, and fill the sleeves with straw.



5. Finish with the pole, grass, and clouds in the sky.



6. Trace the drawing with a black marker. Fill in carefully with your favorite colors.

Scarecrow



Sheriff Costume



Sheriff Costume

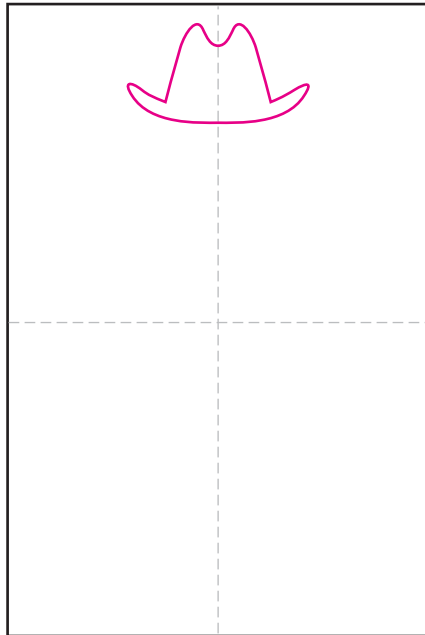

1. Draw the cowboy hat.

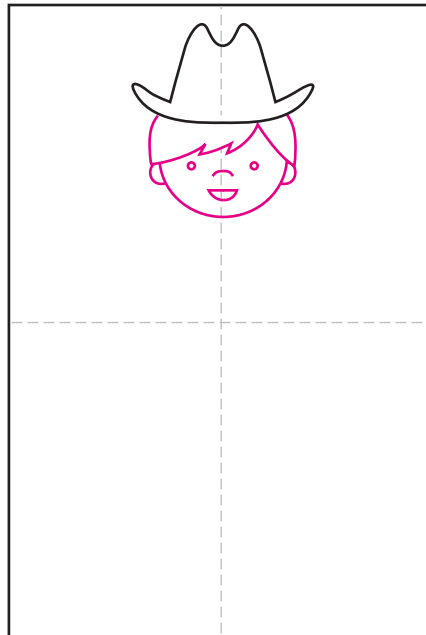

2. Draw the head below the hat.

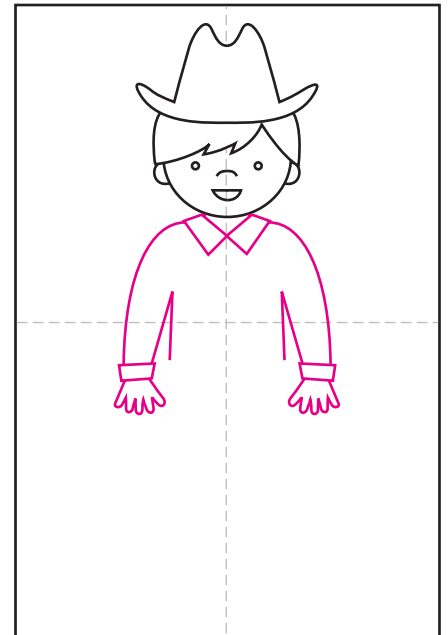

3. Draw the shirt and hands.

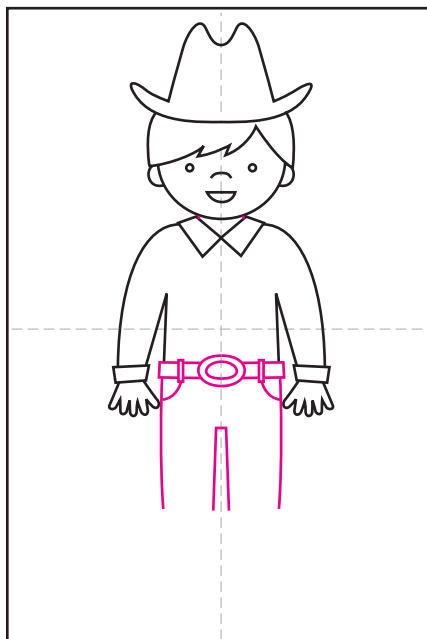

4. Draw the belt and the jeans.

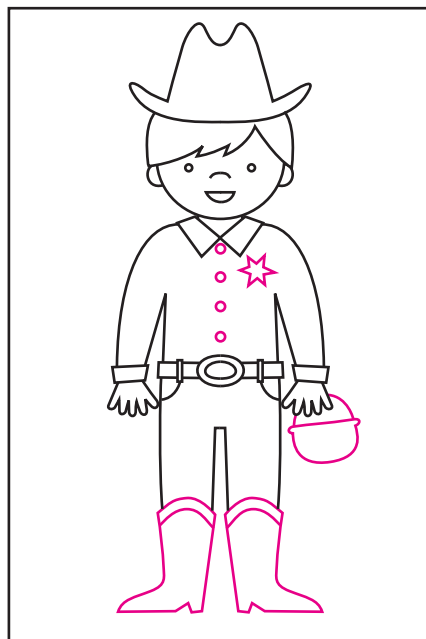

5. Finish with the boots. Add buttons and stars to the shirt. Add a candy pail.



6. Trace the drawing with a black marker. Fill in carefully with your favorite colors.

Sheriff Costume

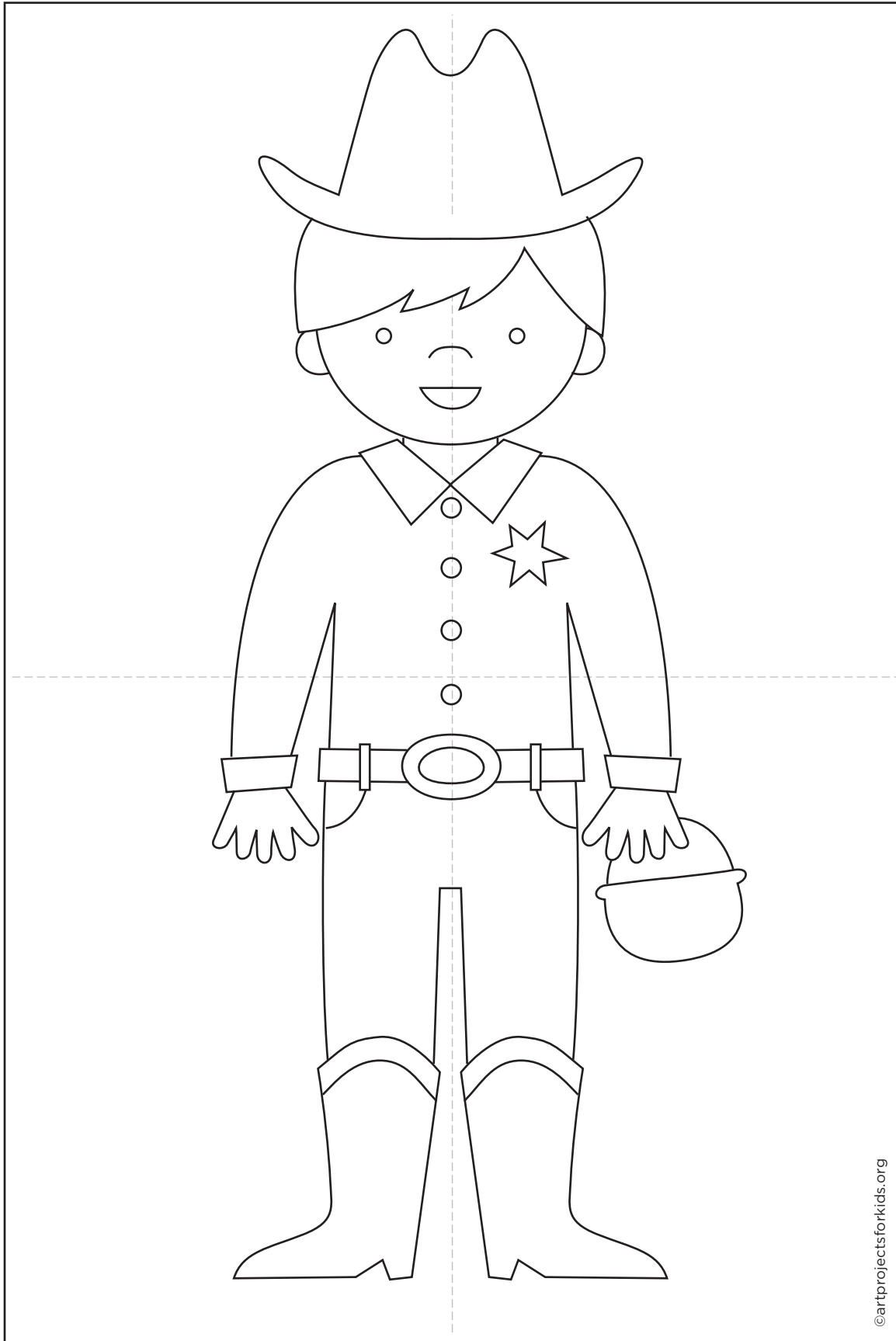

Skull

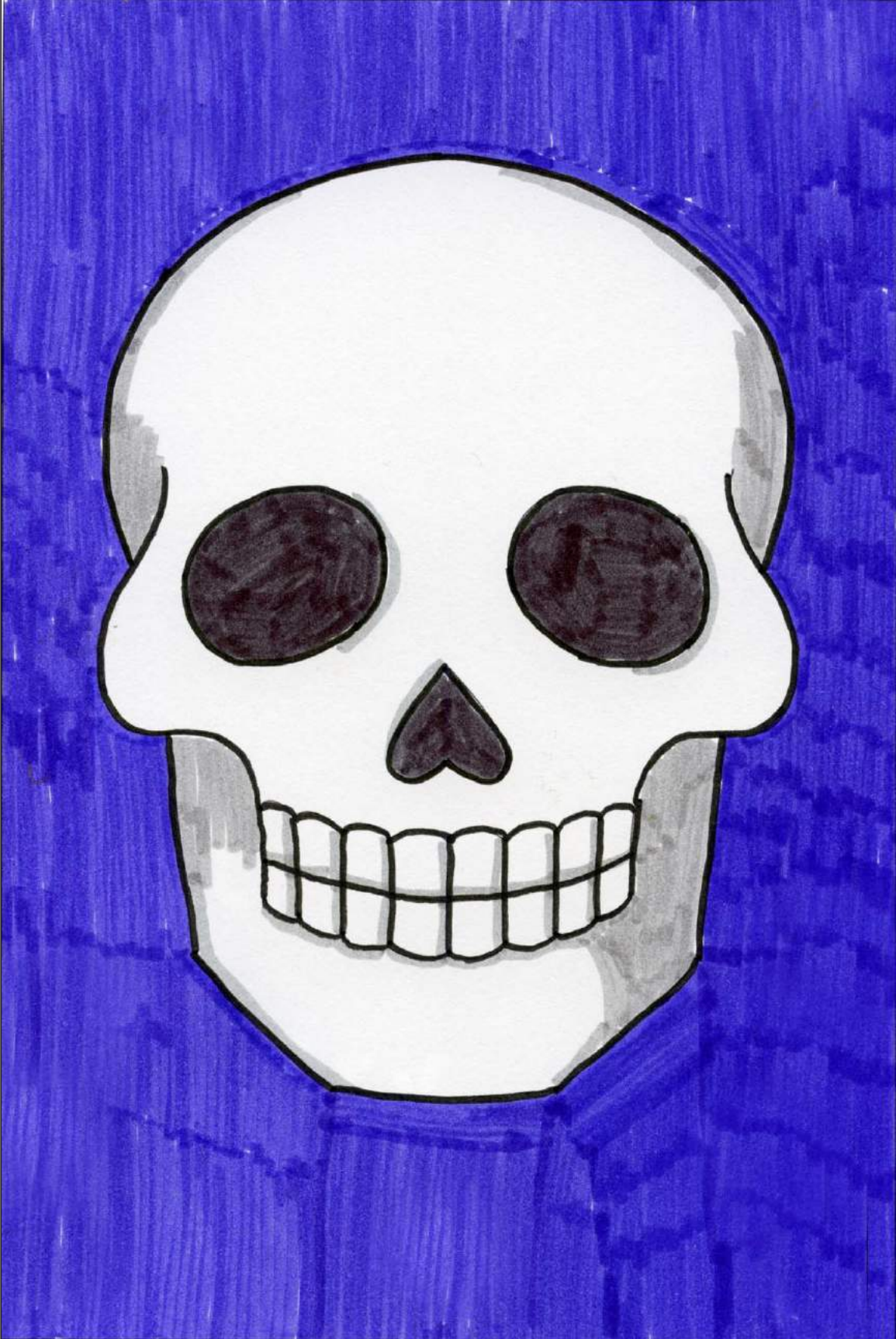

Skull

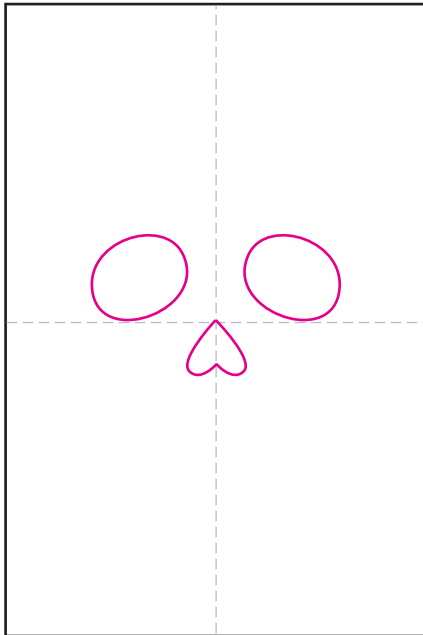

1. Draw the nose hole and two eye sockets.

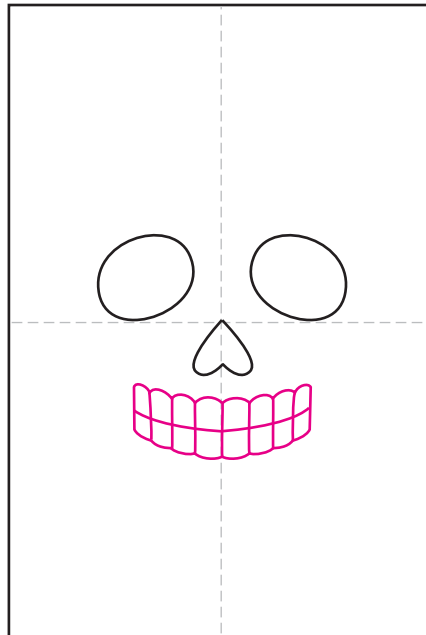

2. Draw a full set of teeth.

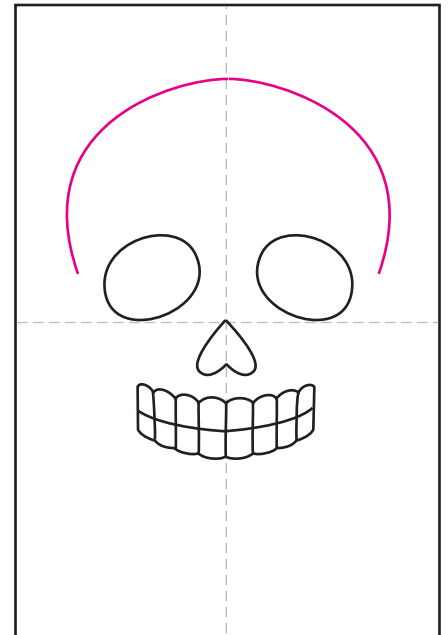

3. Start the top of the head.

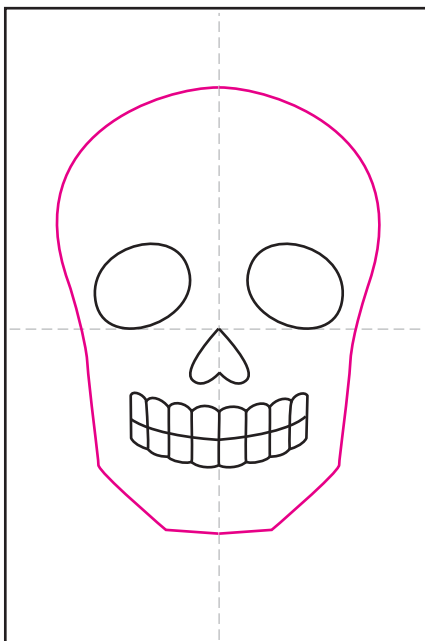

4. Continue and finish the jaw line.

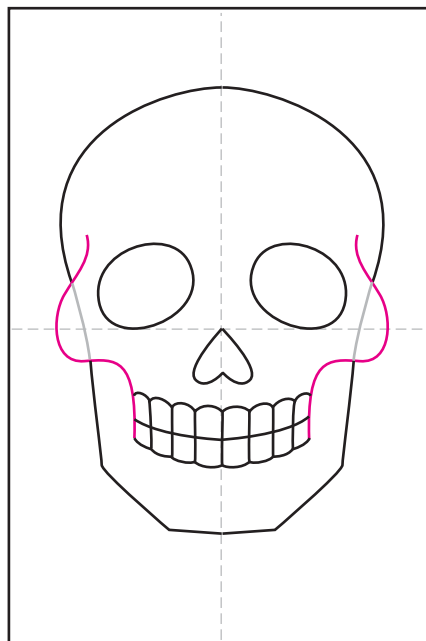

5. Add two symmetrical cheek bones. Erase the lines inside.

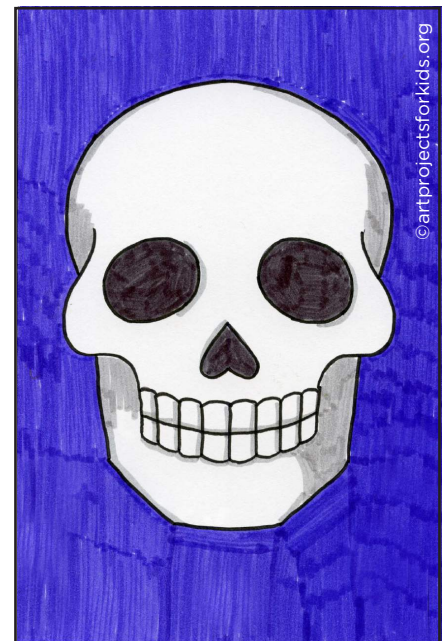

6. Trace the drawing with a black marker. Fill in carefully with black and gray for some shadows.

Skull

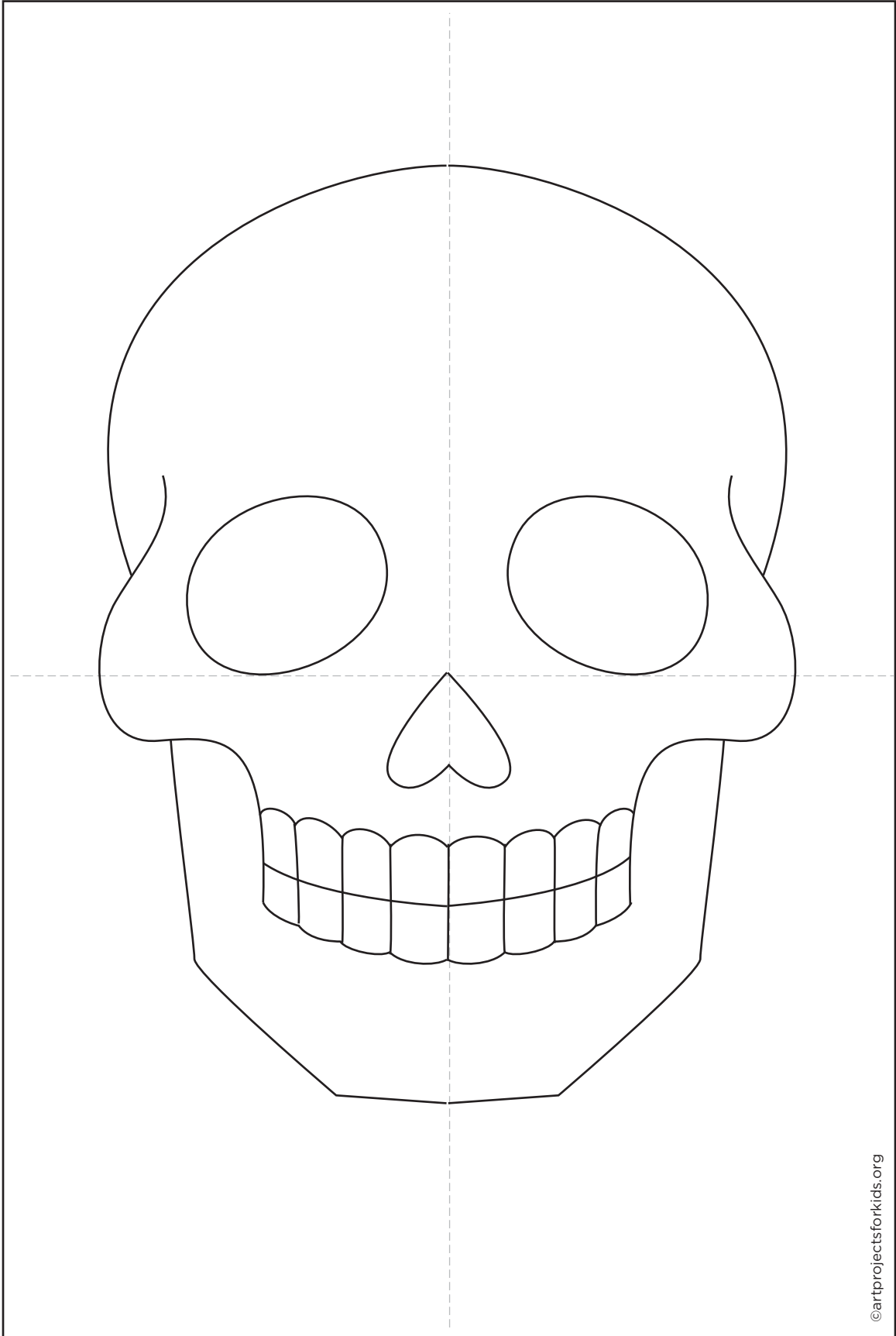

Spider in a Web



Spider in a Web

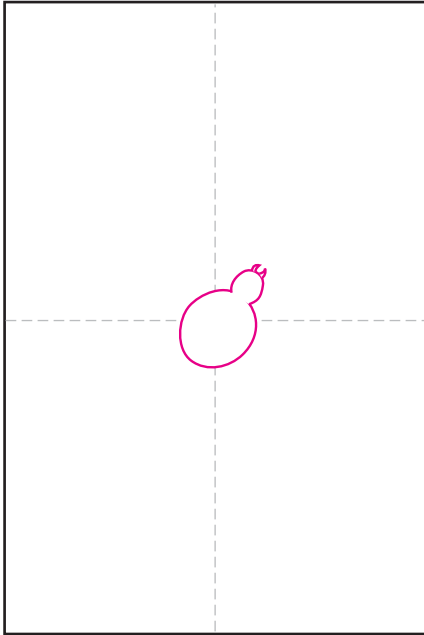

1. Draw two circles for the spider body.

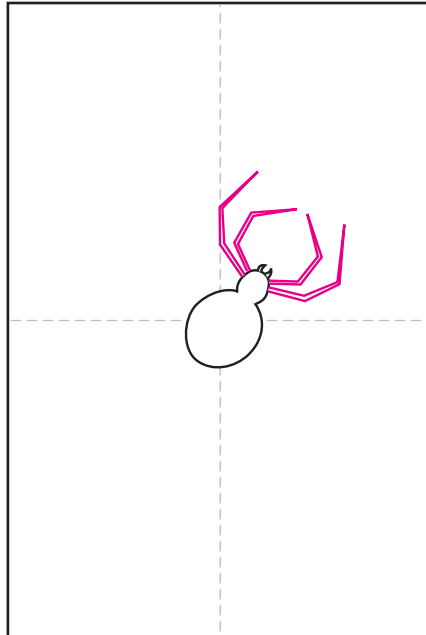

2. Draw a pair of matching front legs.

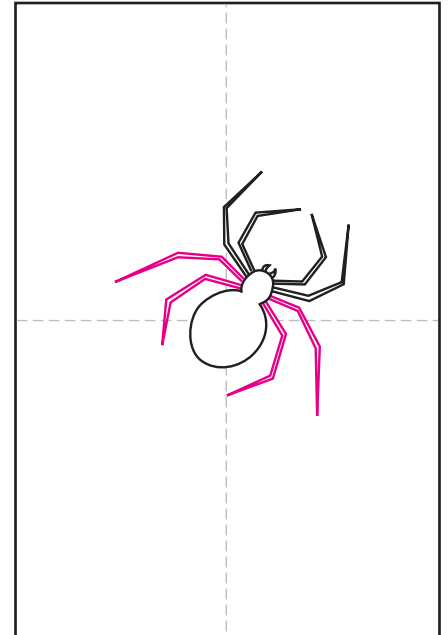

3. Draw a pair of matching back legs.

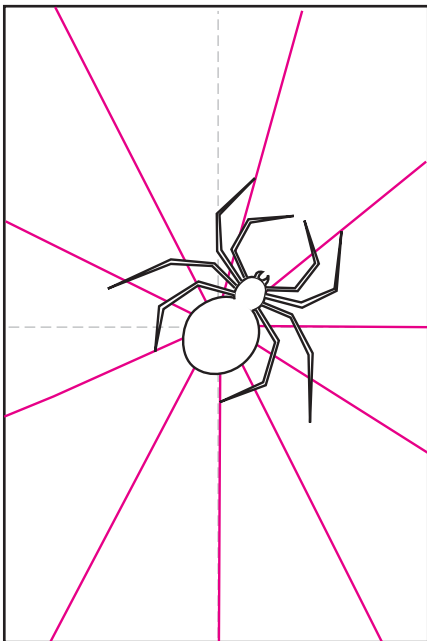

4. Start the spider web with radiating straight lines.

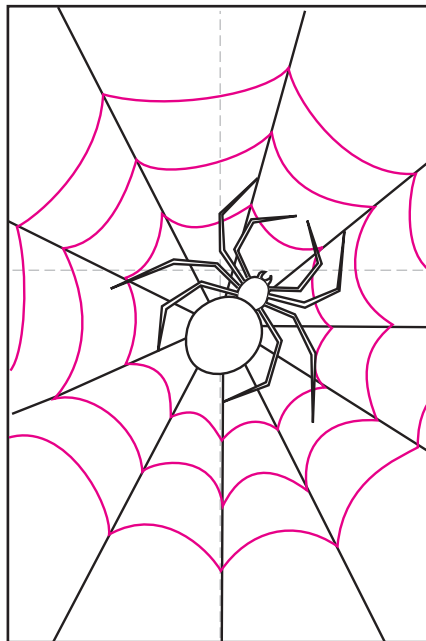

5. Finish the spider web with the curved rings.



6. Trace the drawing with a black marker. Color the spider black. Fill in the background. Add an extra gray line to make a shadow.

Spider in a Web

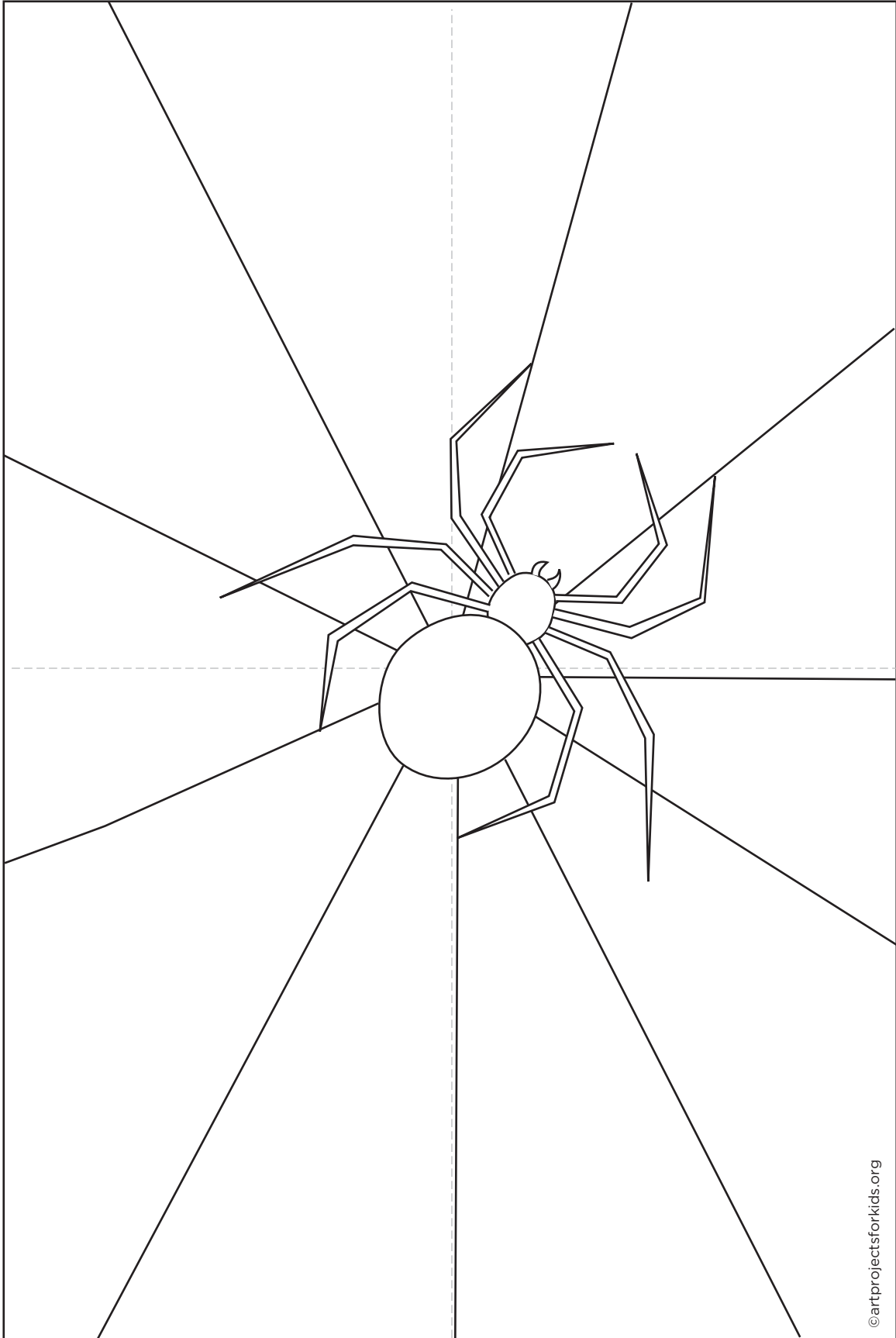

Spider Web



Spider Web

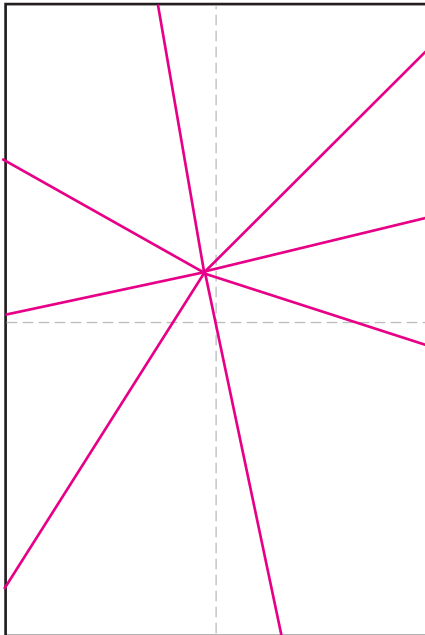

1. Make a dot for the center of your web, and draw 8 lines extending from it. A ruler make be helpful.

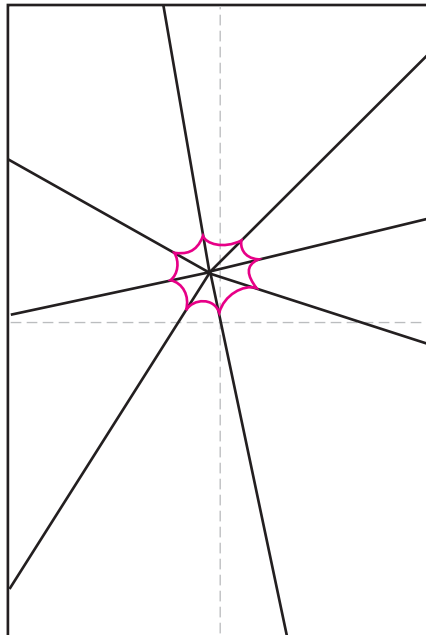

2. Start in the center and draw a small ring as shown. Be sure to curve the lines, and not draw just straight ones.

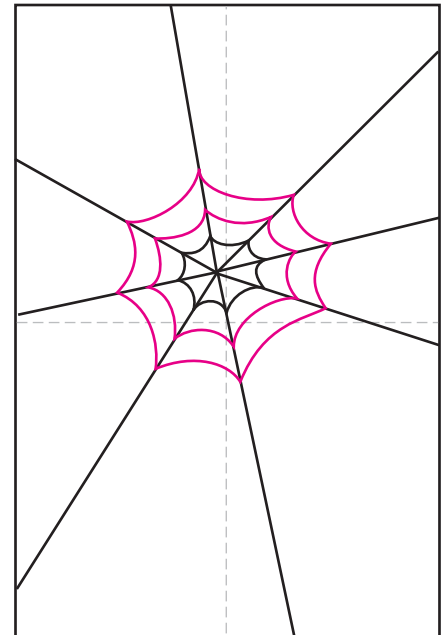

3. Continue making more rings, as evenly spaced as you can.

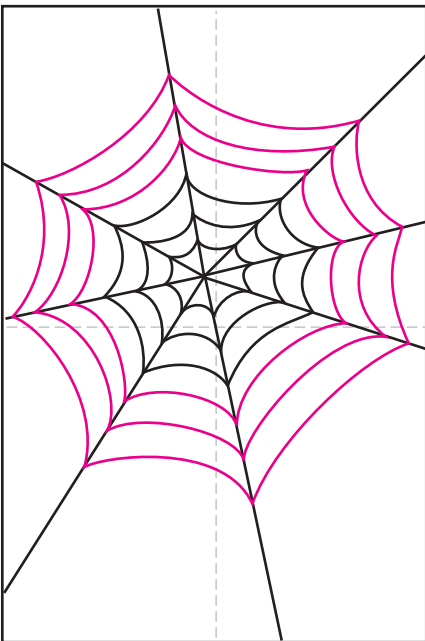

4. Continue making more rings until you run out of room.



5. Trace the web with a black permanent marker.



6. Color the background right over the web lines. When finished, add a gray line beside each to make a shadow.

Spider Web

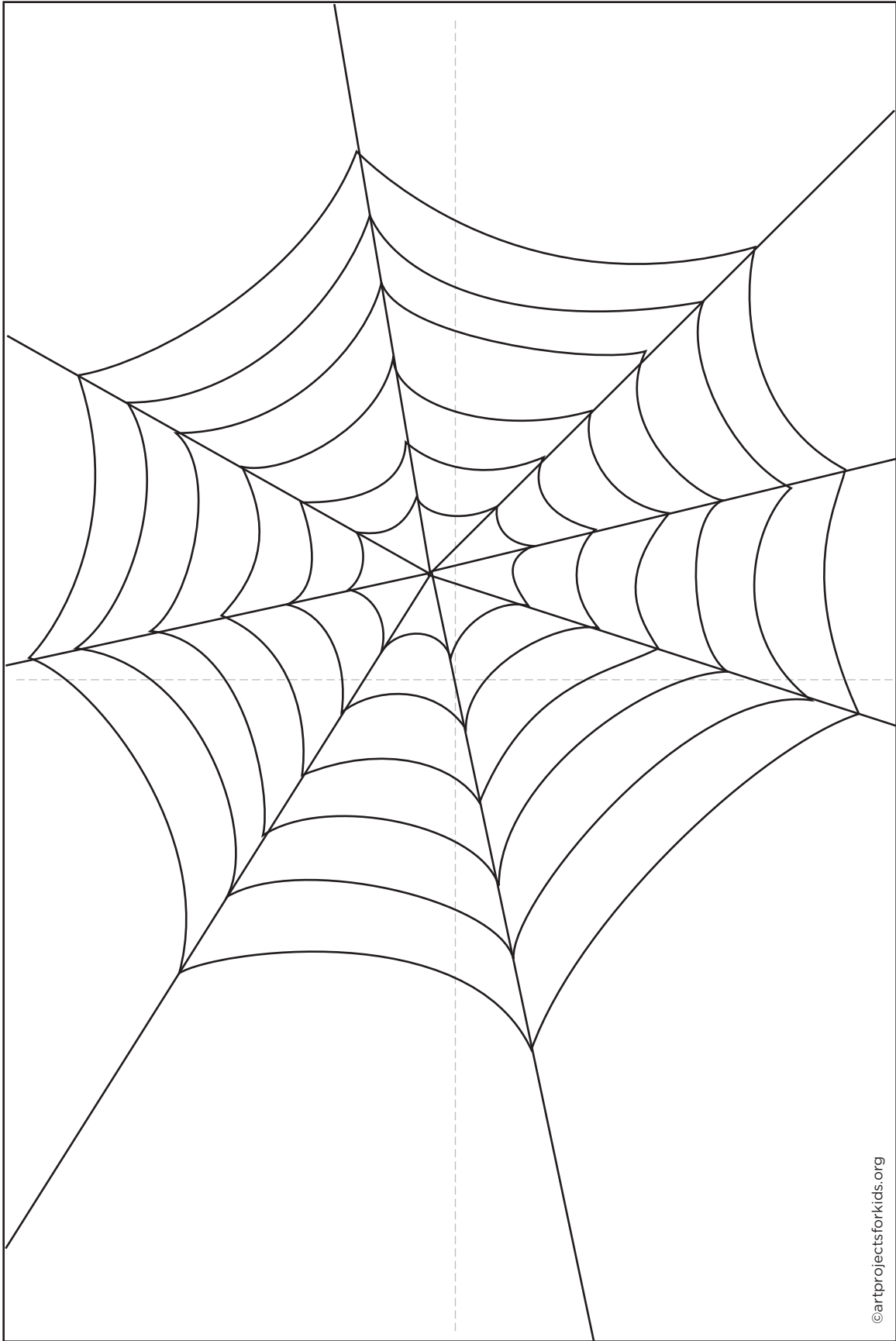

Supergirl Costume



Supergirl Costume

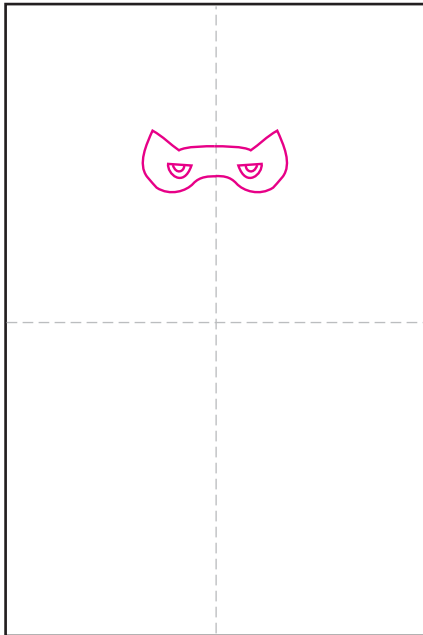

1. Start with drawing the mask.

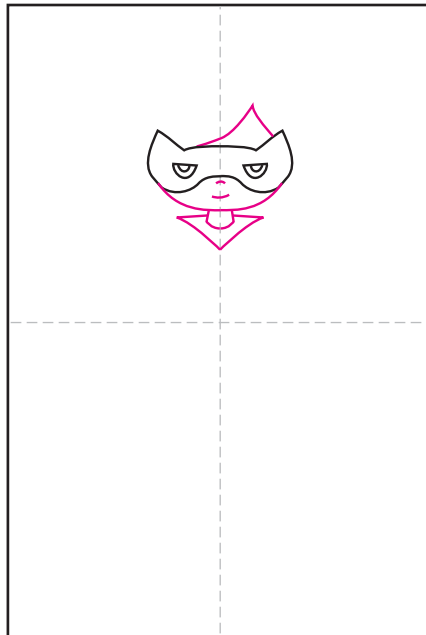

2. Add the part above and the face and neck below.

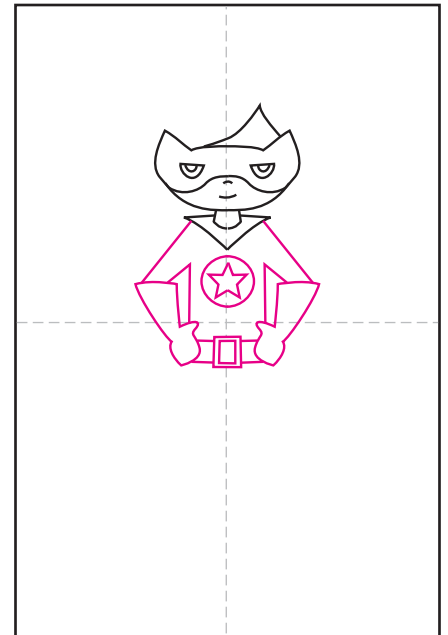

3. Draw the arms and torso.

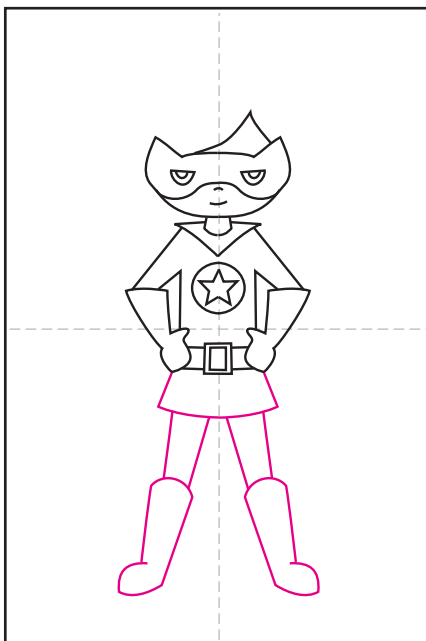

4. Add a skirt and legs with boots.

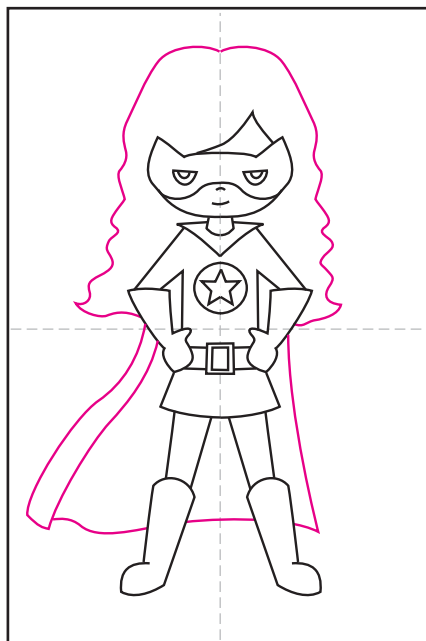

5. Finish with hair and cape that flow behind her body.



6. Trace the drawing with a black marker. Fill in carefully with your favorite colors.

Supergirl Costume

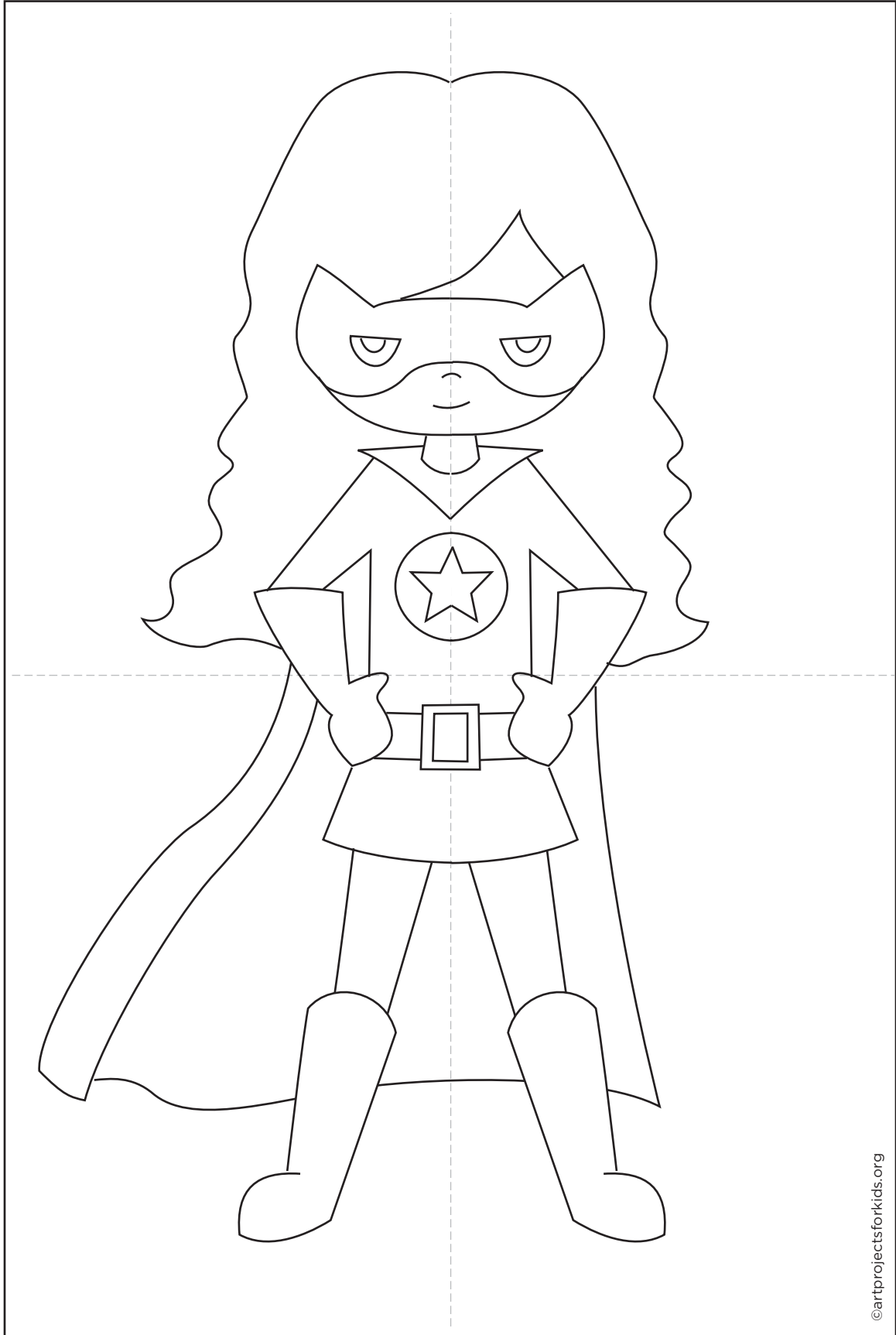

Vampire Costume



Vampire Costume

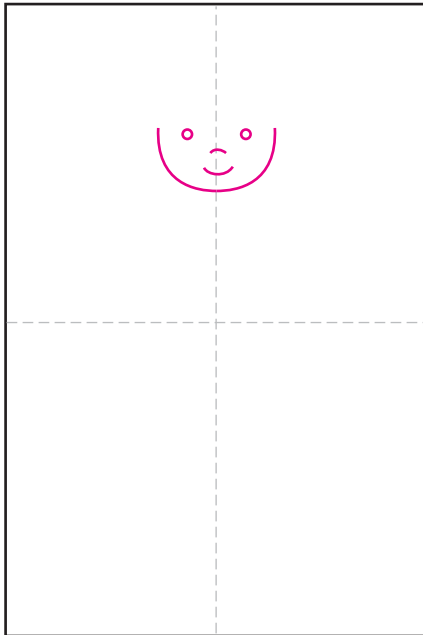

1. Draw a U to make a simple face.

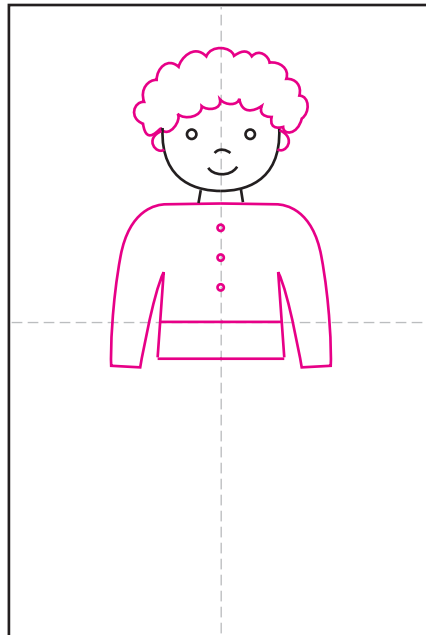

2. Add the hair above, and then start the shirt and arms below.

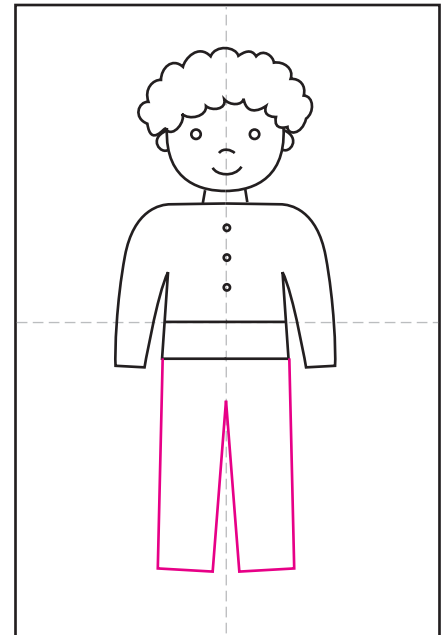

3. Draw the pants.

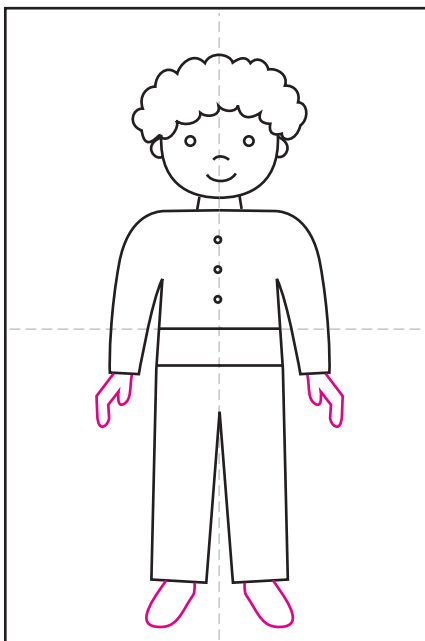

4. Add hands and shoes.

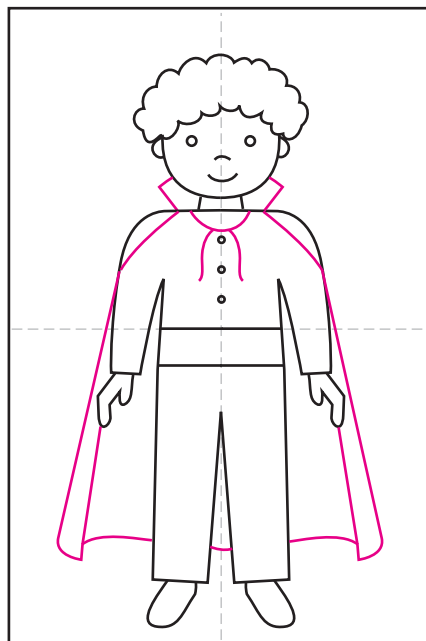

5. Finish with a cape and tie.



6. Trace the drawing with a black marker. Fill in carefully with your favorite colors.

Vampire Costume

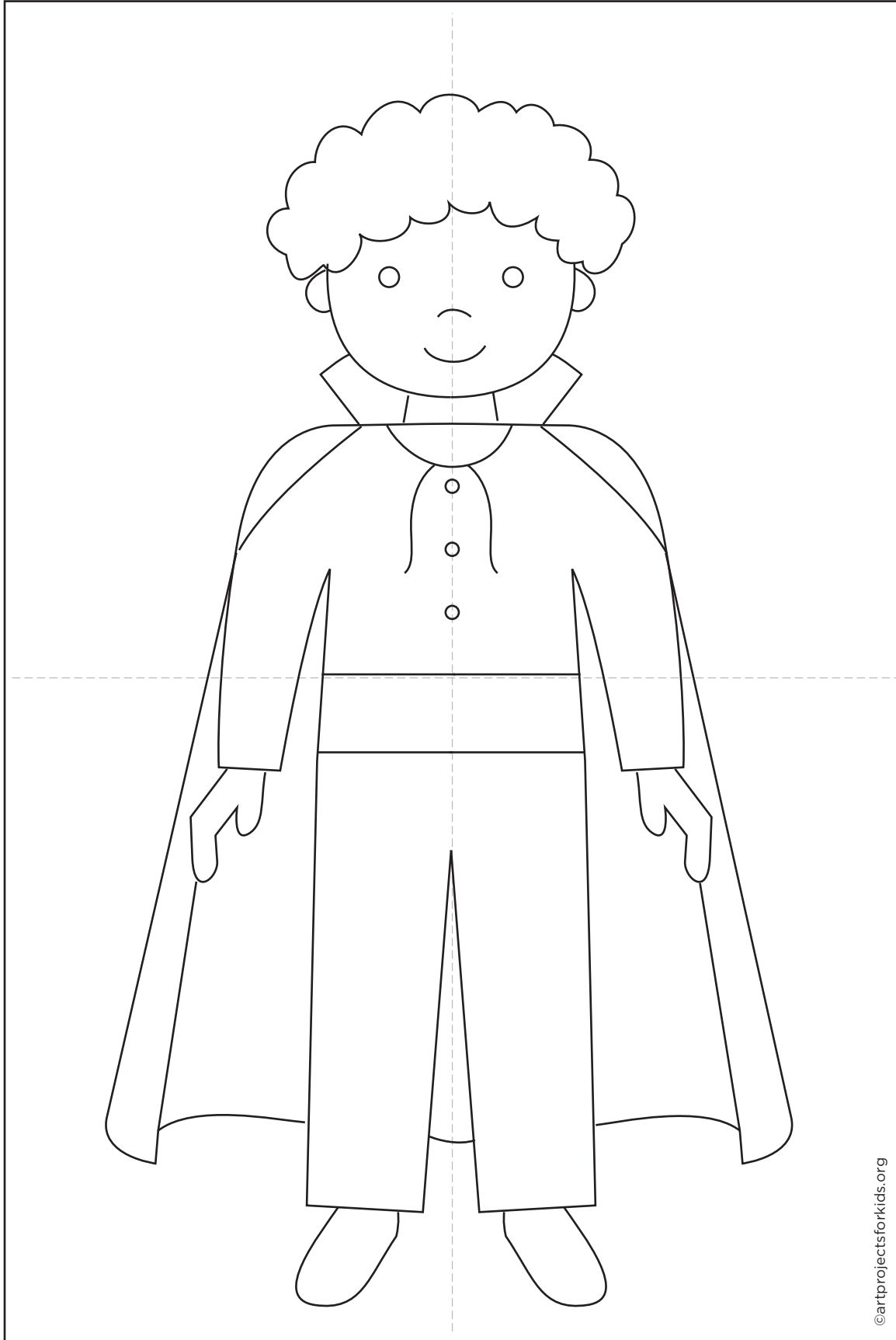

Vintage Cat Face



Vintage Cat Face

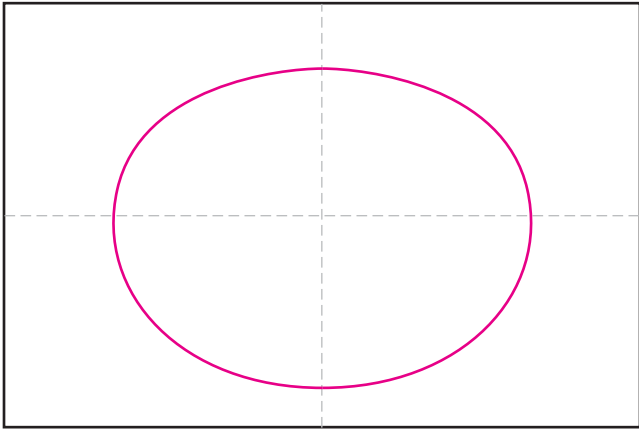

1. Draw a wide oval.

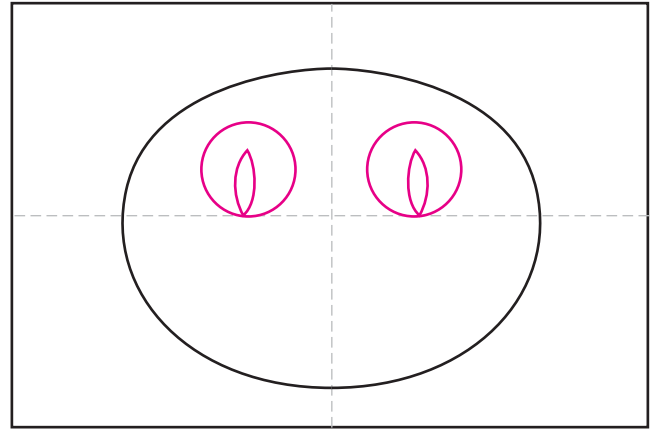

2. Add two circle eyes and sliver shapes. Make sure there is space above them so the eyes look wide open.

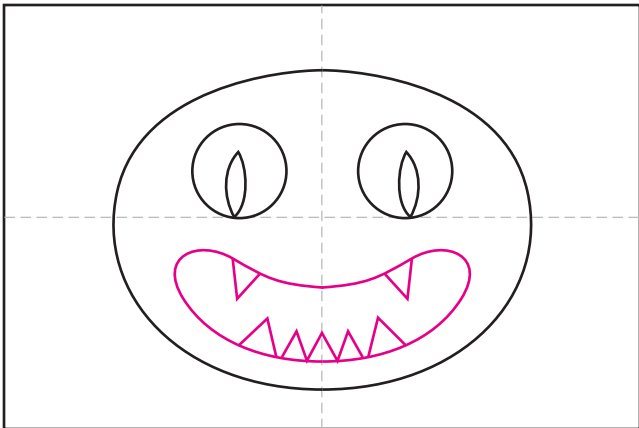

3. Draw a rounded mouth with point teeth.

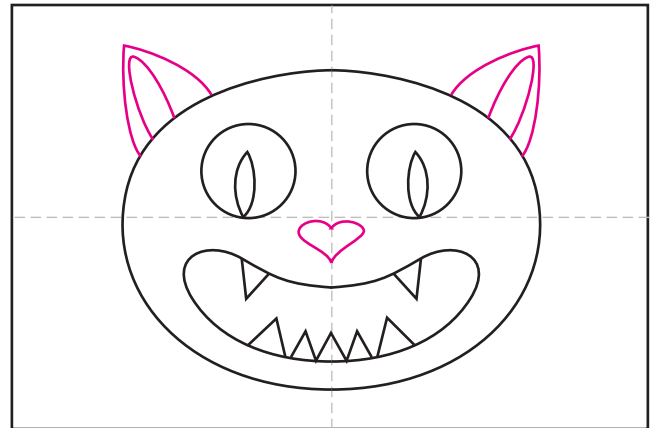

4. Add a small nose and two ears.

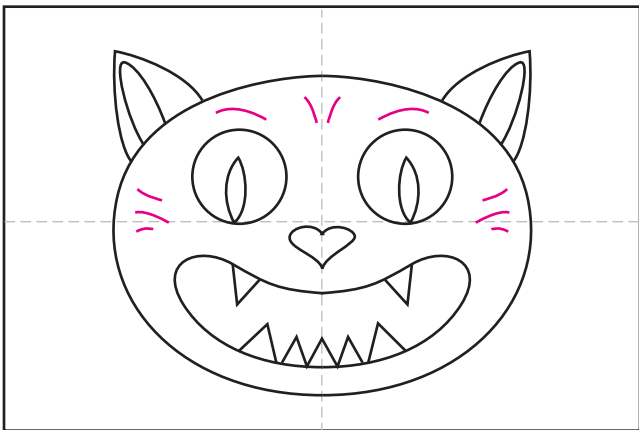

5. Finish with some whisker and fur lines.



6. Trace the drawing with a black marker. Trace the fur lines with a gray marker. Fill in carefully with your favorite colors.

Vintage Cat Face

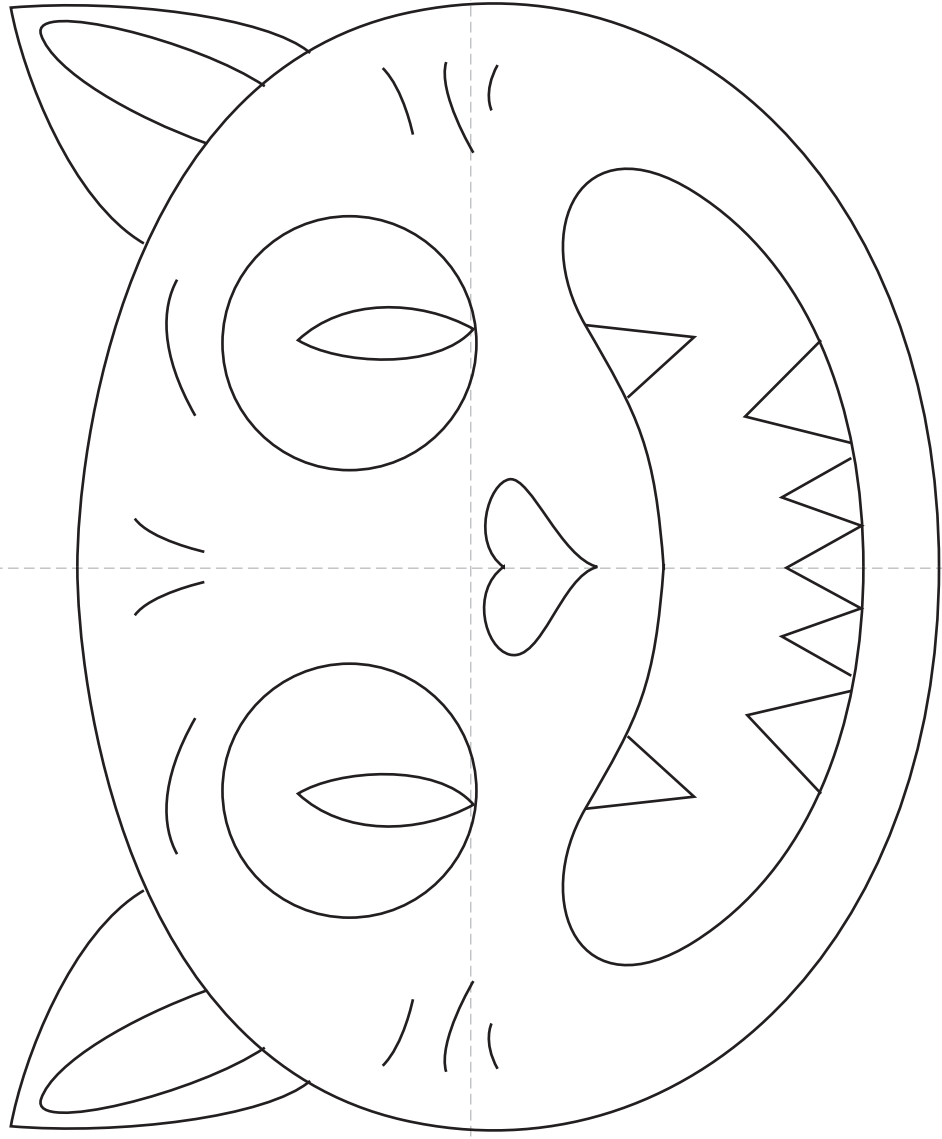

Witch Costume



Witch Costume

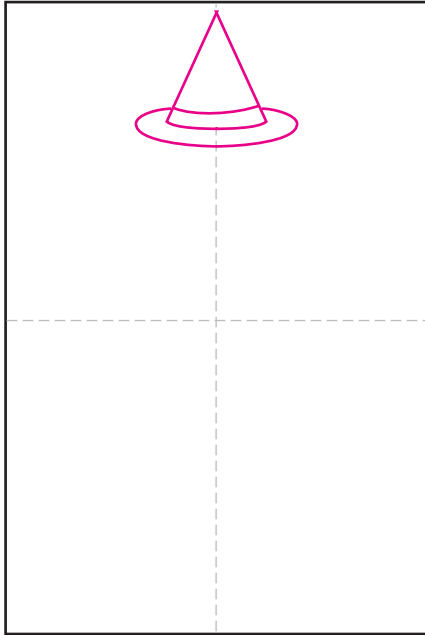

1. Draw the witch hat.

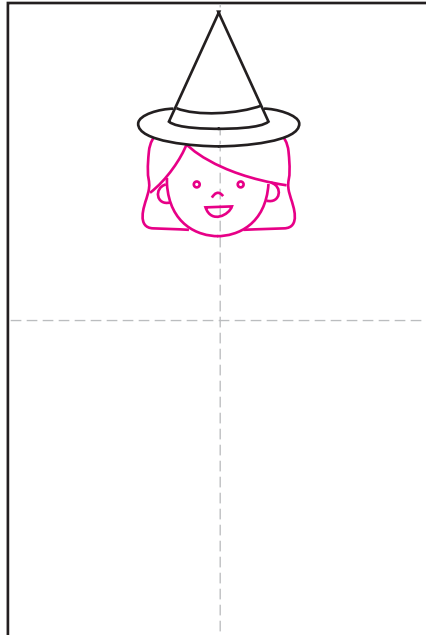

2. Draw the head below the hat.

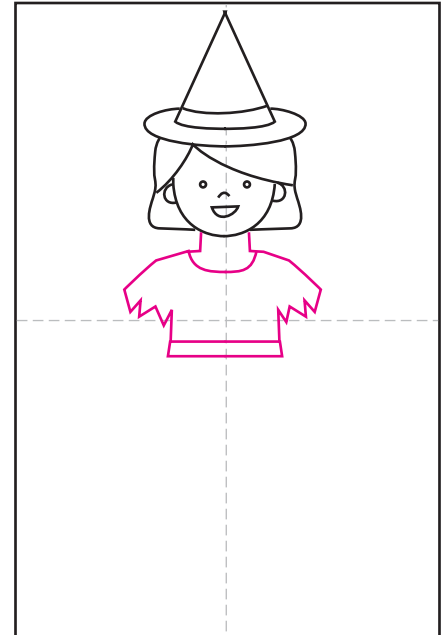

3. Draw the top of the dress.

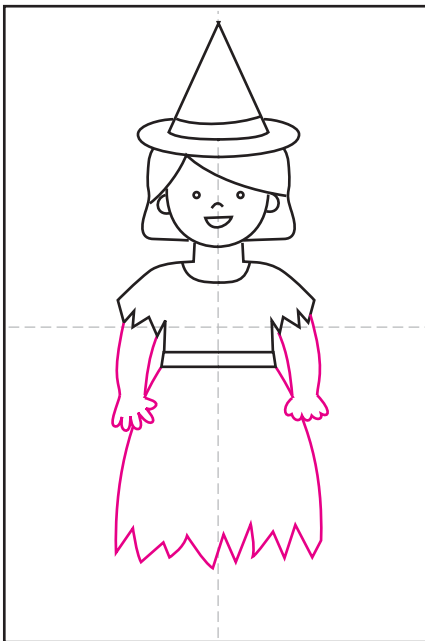

4. Add the bottom of the dress, and two arms coming out of the sleeves.

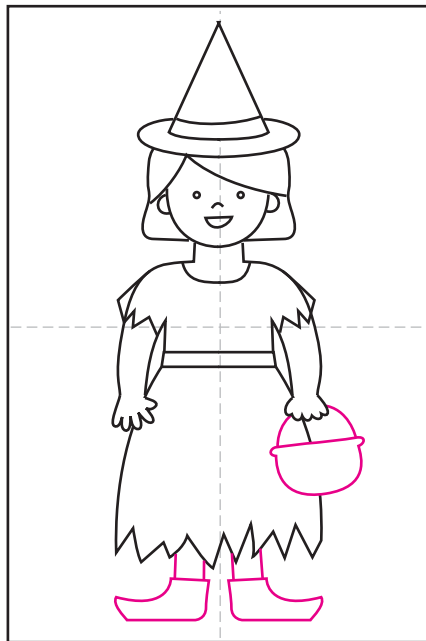

5. Finish with two feet and a candy pail.



6. Trace the drawing with a black marker. Fill in carefully with your favorite colors.

Witch Costume

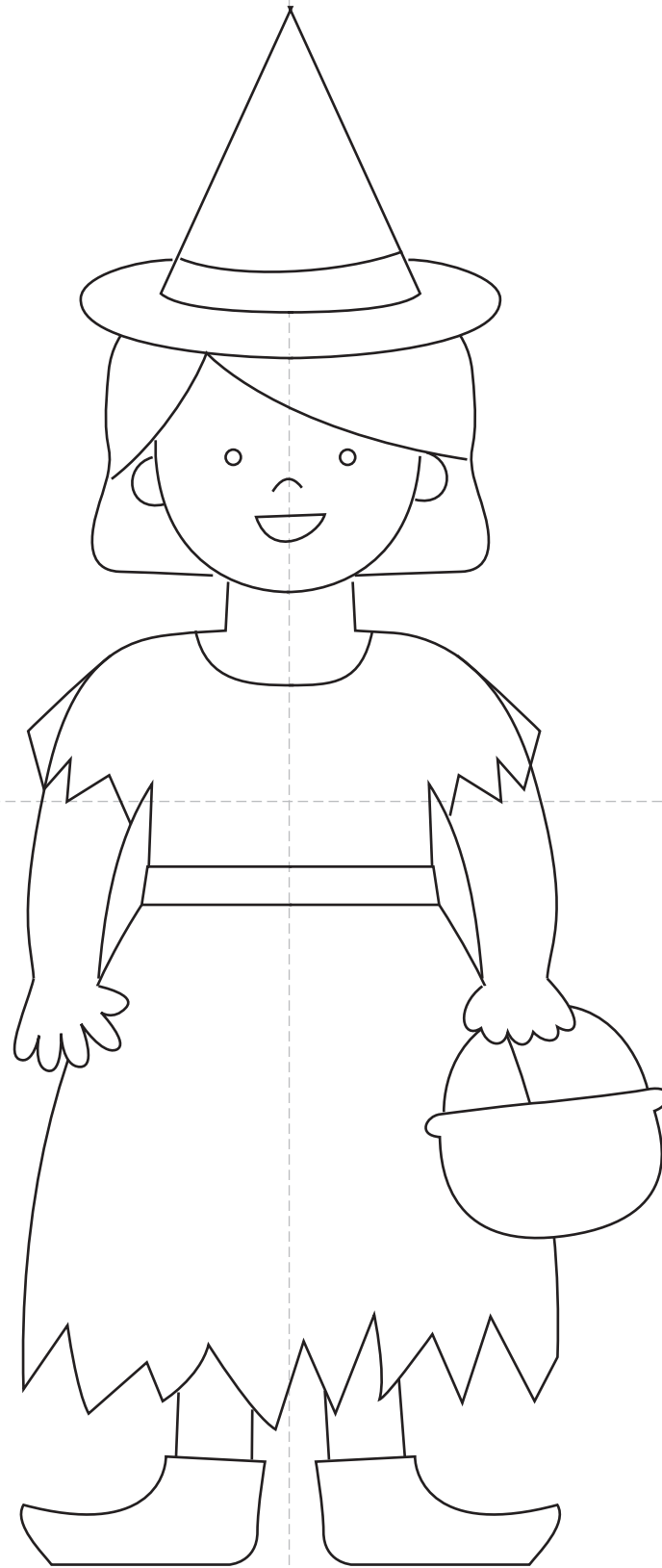

Witch Hat

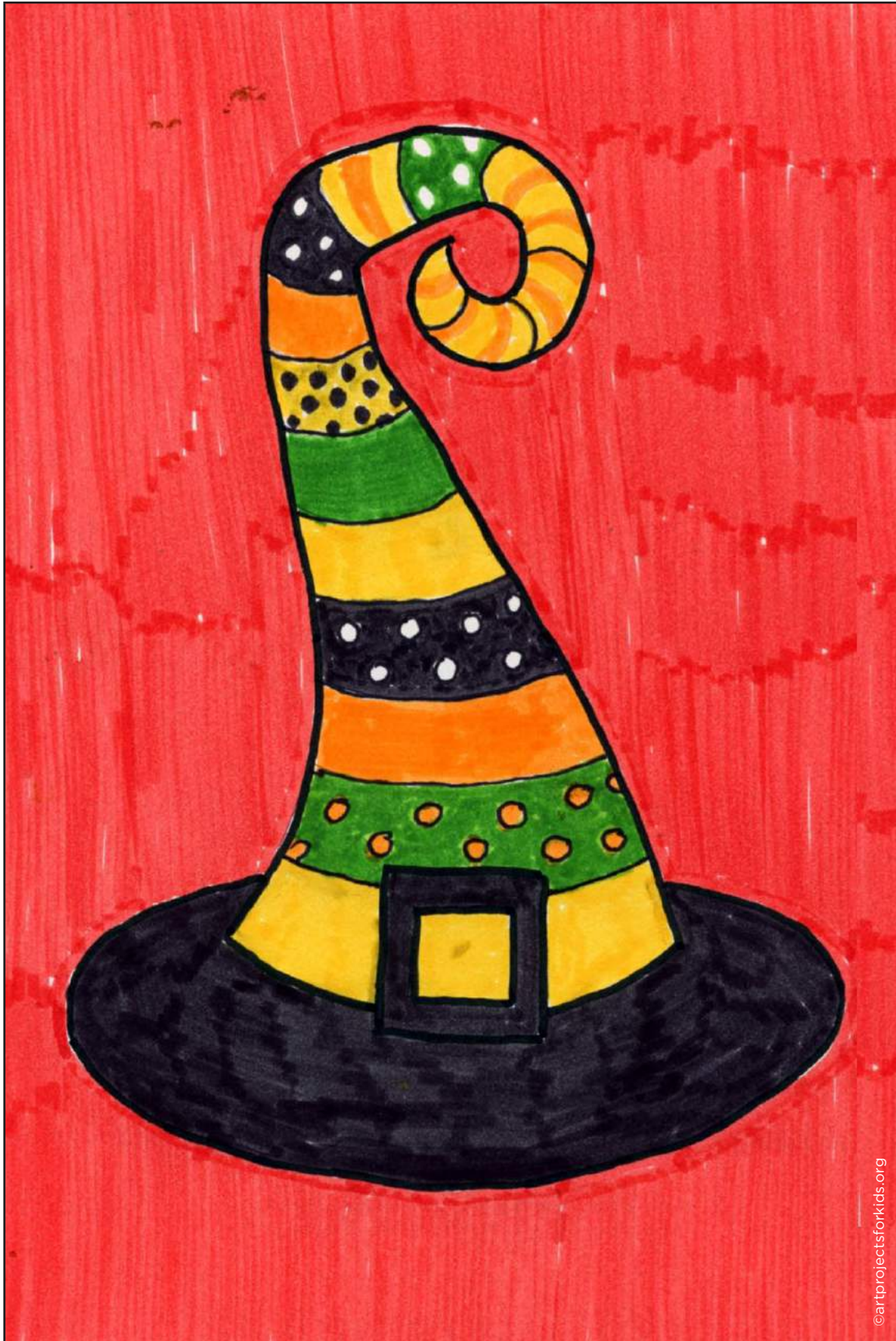

Witch Hat

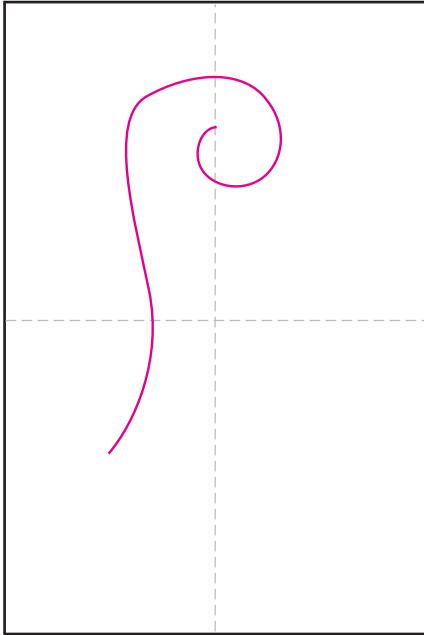

1. Start with a curved line.

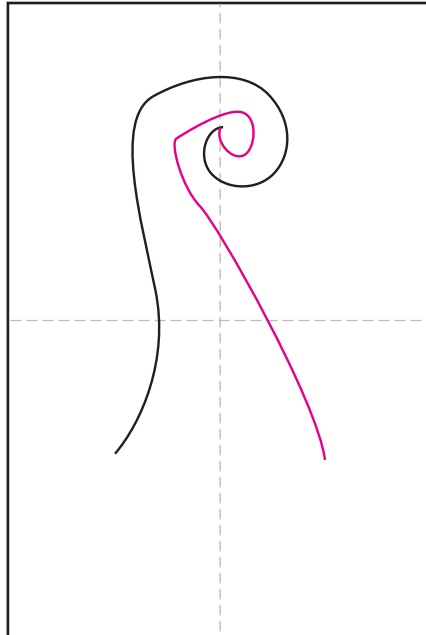

2. Draw another curve that meets at the tip.

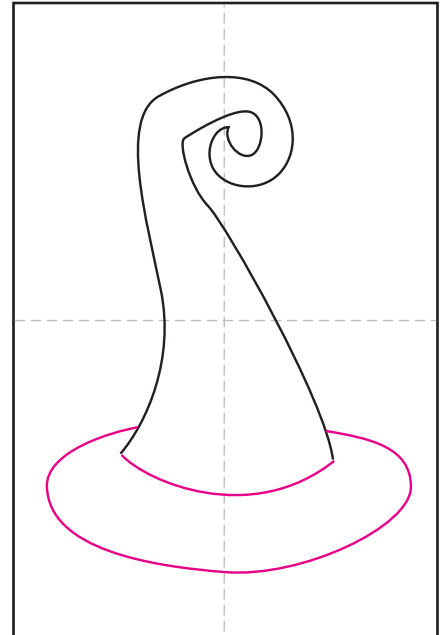

3. Add a rounded hat rim.

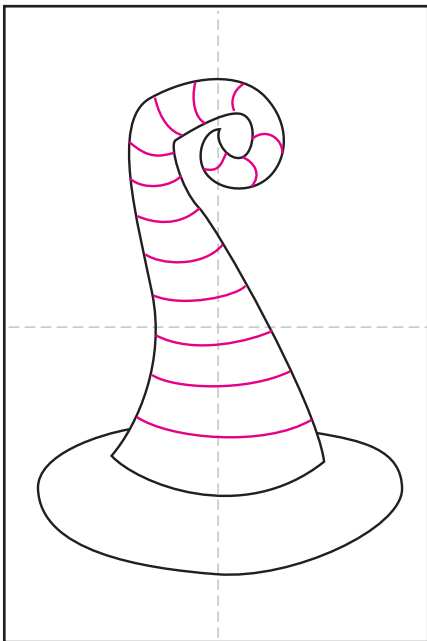

4. Draw curved lines to make lots of stripes.

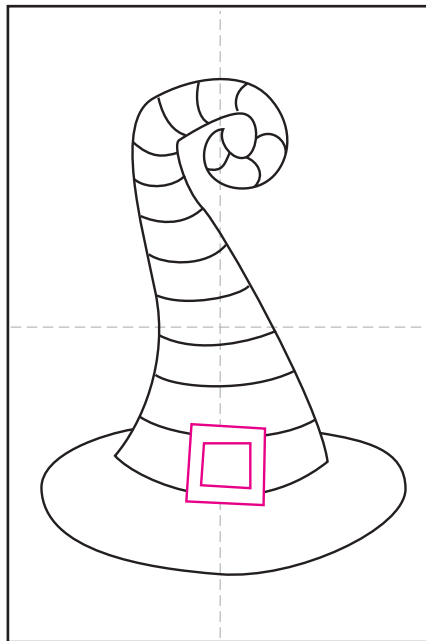

5. Finish with a buckle.

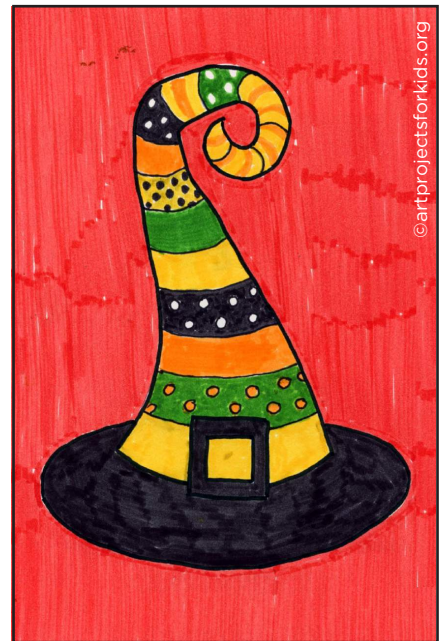

6. Trace the drawing with a black marker. Have fun filling the stripes with lots of different patterns.

Witch Hat

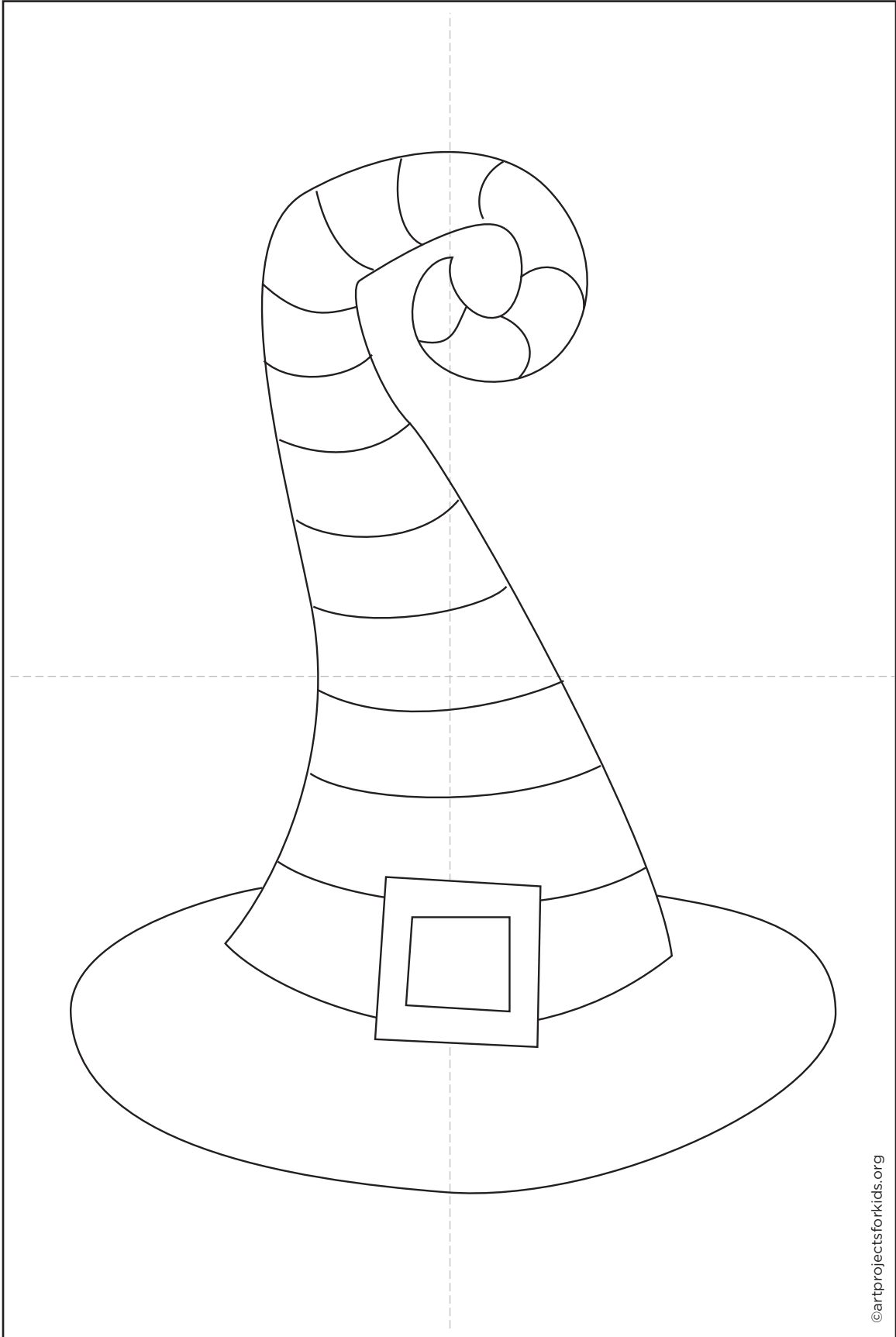

Witch Legs



Witch Legs

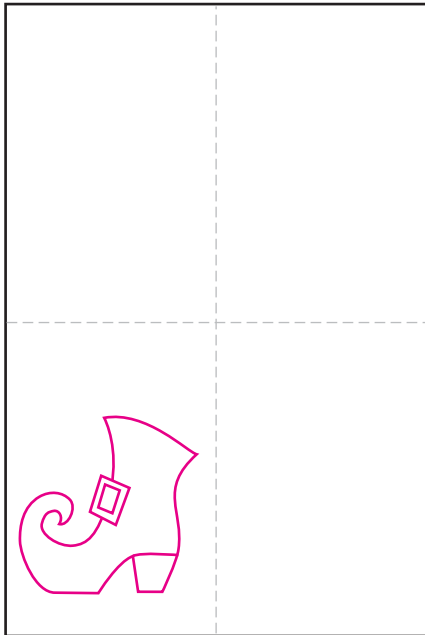

1. Draw the left shoe and buckle.

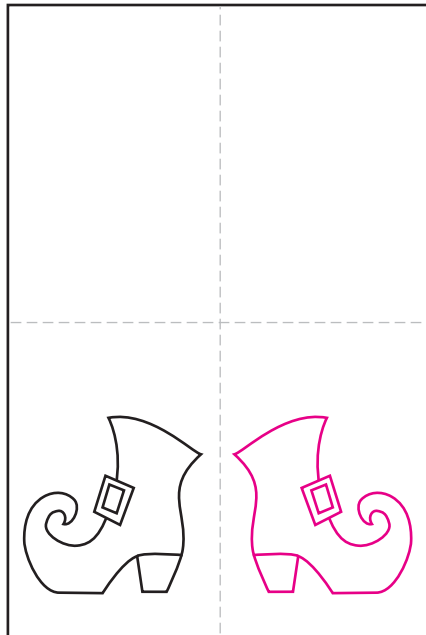

2. Draw a symmetrical right shoe and buckle.

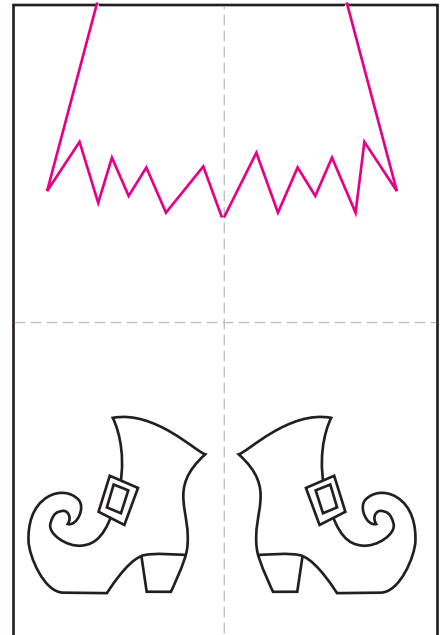

3. Draw the the bottom of a raggedy witch dress.

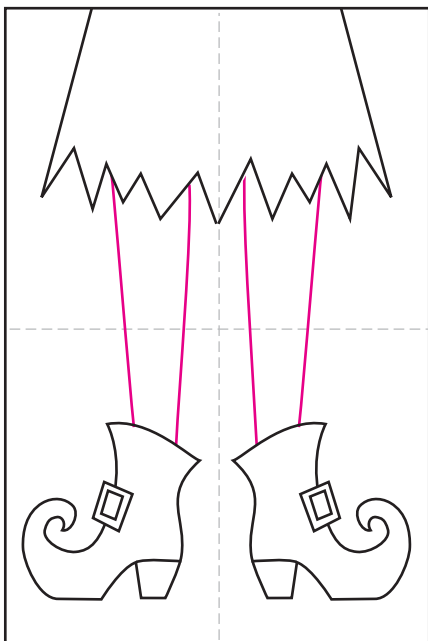

4. Connect the shoes and dress with leg lines.

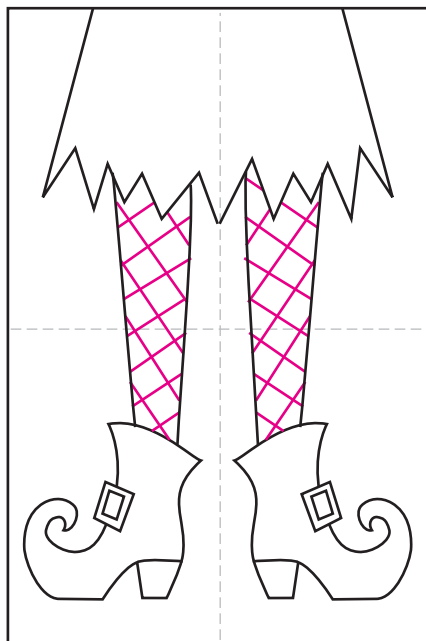

5. Draw a criss cross or other pattern to turn the legs to stockings.



6. Trace the drawing with a black marker. Fill in carefully with your favorite markers.

Witch Legs

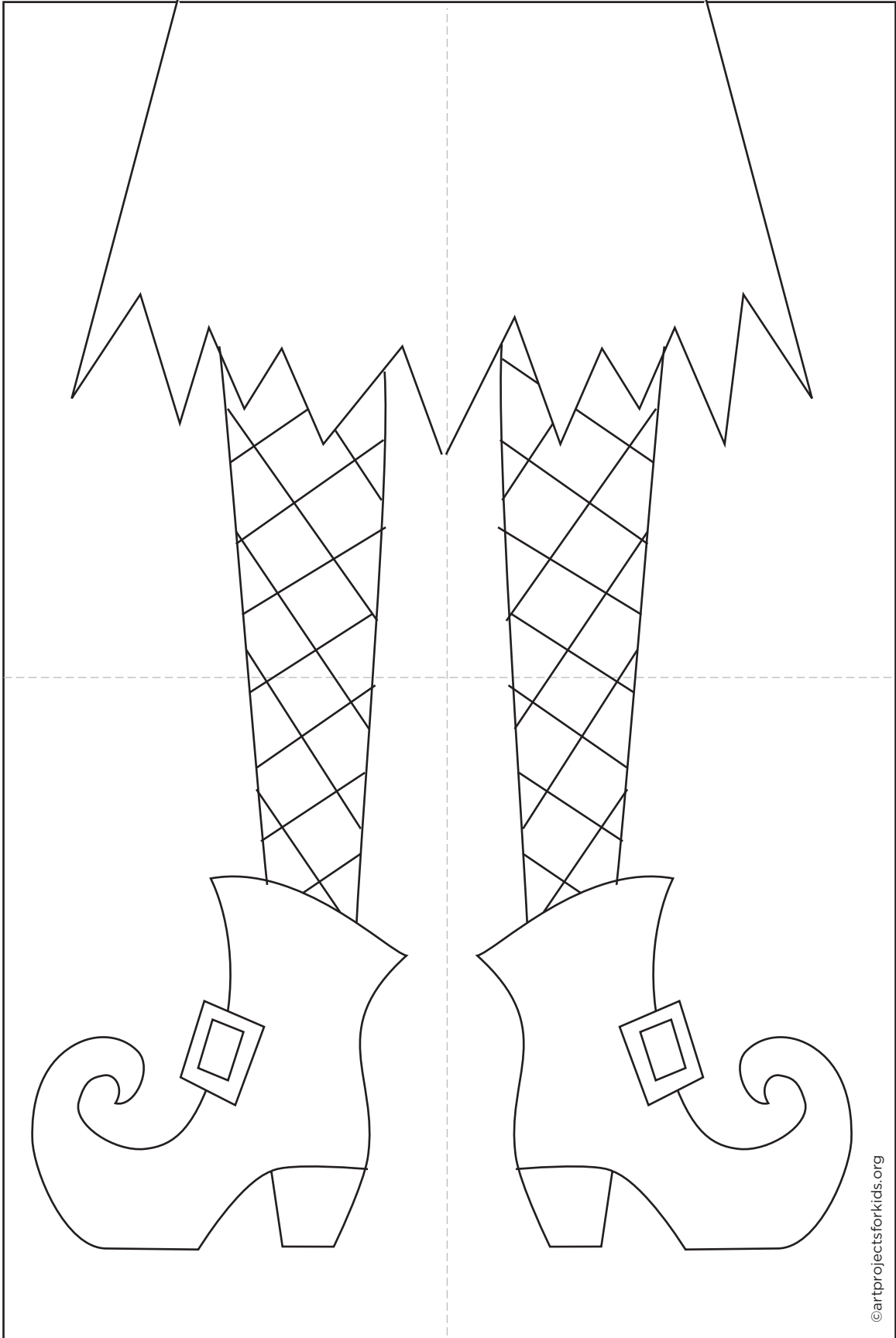

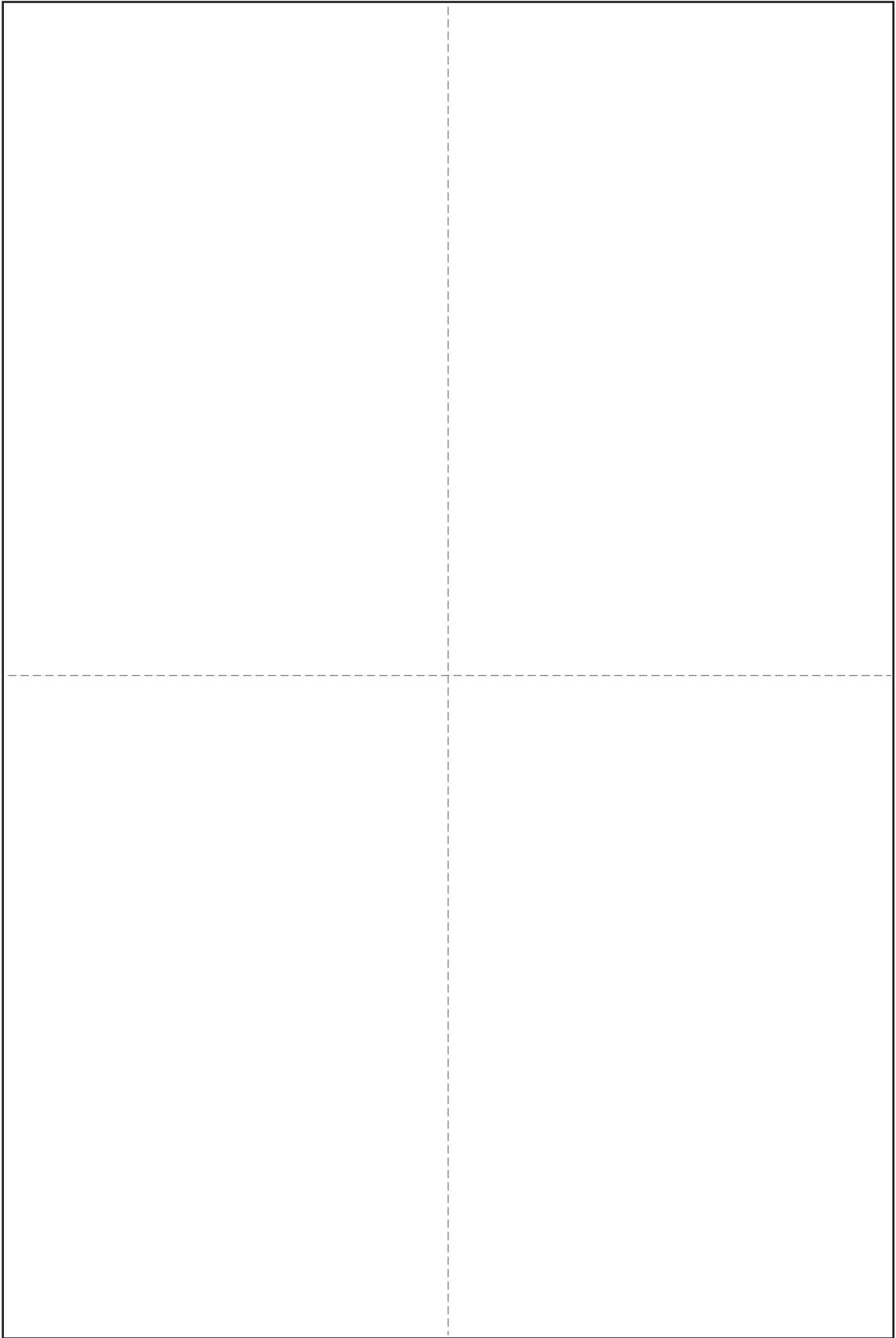

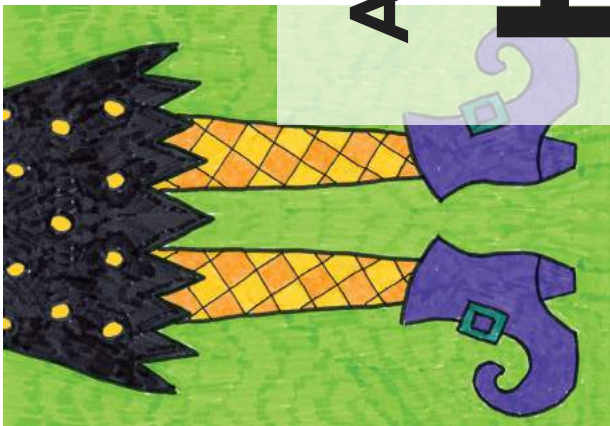

ART PROJECTS FOR KIDS
HALLOWEEN



DRAWINGS

Cover art for the sleeve of a binder. Cut, tape to top.

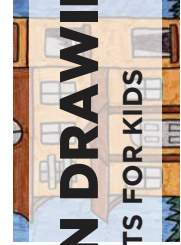
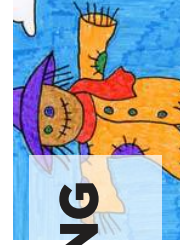
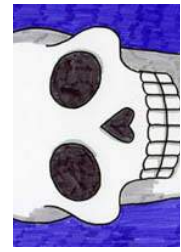
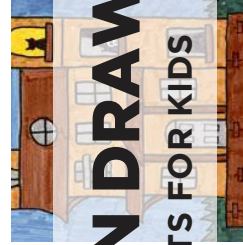
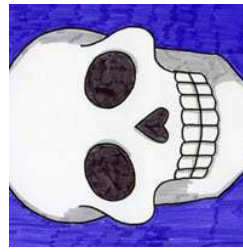
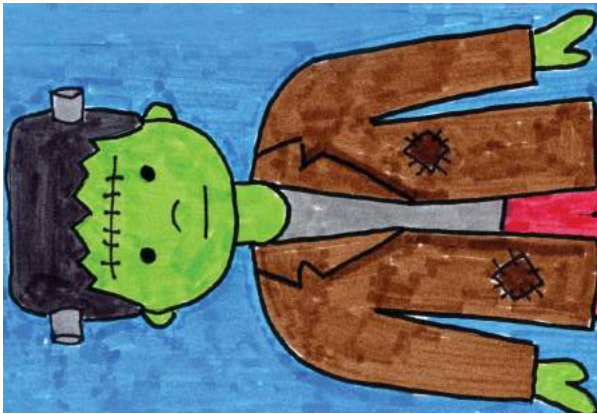
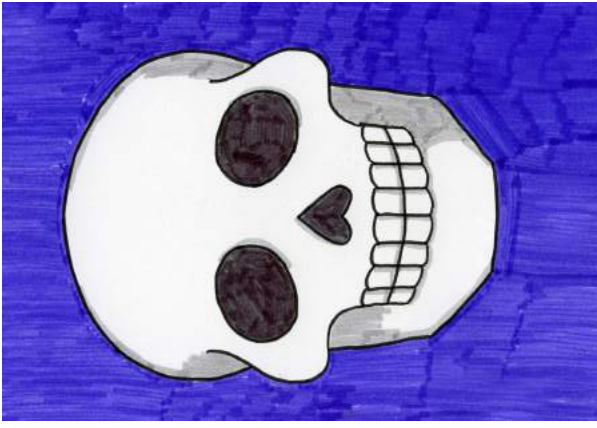

HALLOWEEN DRAWING

ART PROJECTS FOR KIDS

HALLOWEEN DRAWING

ART PROJECTS FOR KIDS