

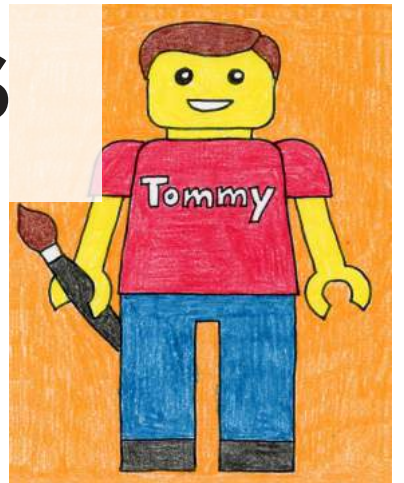

ART PROJECTS FOR KIDS

# Self Portrait



## ART PROJECTS

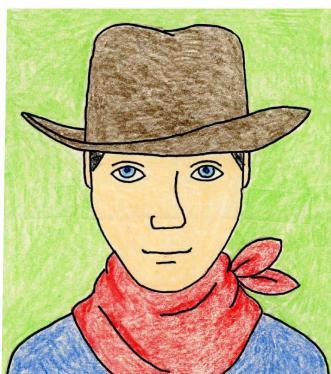
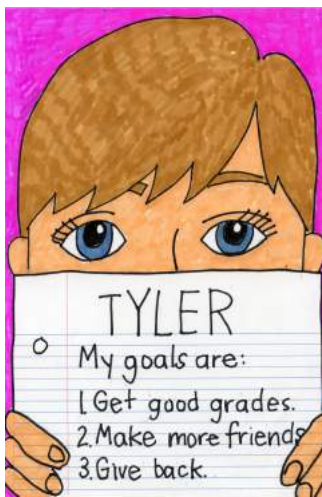
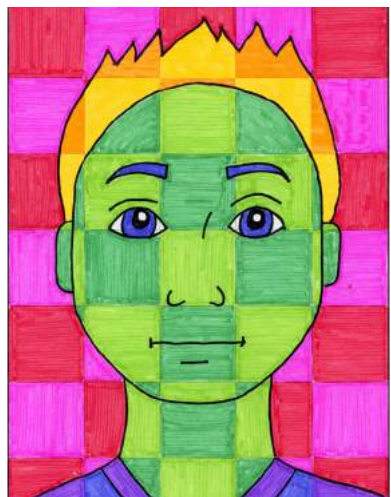

# SELF PORTRAIT PROJECTS INDEX



Paul Klee page 3



Cubism page 6



Statue of Liberty page 9



Big Face page 12



Hundertwasser page 15



Doodle Drawing page 19

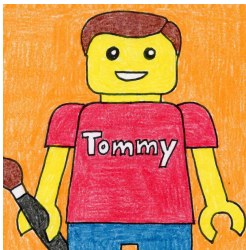

Lego page 23



Sunglasses page 27



Modigliani page 31

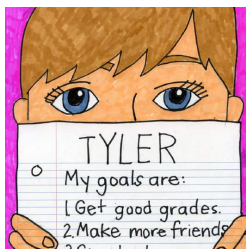

My Goals page 35

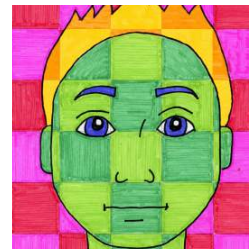

Chuck Close page 39

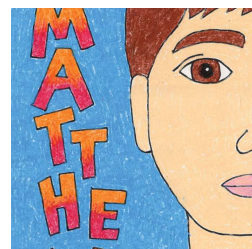

Half Portrait page 43

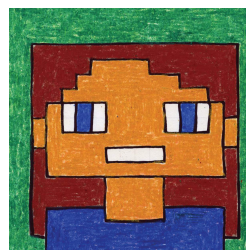

Minecraft page 46



Wanted Poster page 52



Lichtenstein page 58

Paul Klee SELF PORTRAIT



## Paul Klee Self Portrait

Paul Klee was a Swiss-German painter who refused to stick to any single artistic movement over the span of his career. His unique style was influenced by expressionism, cubism, and surrealism.

Klee's famous painting "Senecio" is a fun one to imitate as it uses simple shapes and blocks of color — easy to do with bleeding tissue paper.

I recommended students start this project by tracing a large circle template. Large circles are some of the hardest shapes for them to draw, and if you don't, you might have a lot of students that struggle to draw a perfect circle for too long, and never even get to the tissue painting.

### NATIONAL ARTS STANDARDS

VA:Cr1.2.2a Make art or design with various materials and tools to explore personal interests, questions, and curiosity.



### MATERIALS

- Watercolor paper, 9" x 12"
- Black permanent marker
- Bleeding tissue paper  
(I used Spectra® Art Tissue™ paper)
- Water
- Paint brush

### DIRECTIONS

PREP: Precut lots of tissue paper into 2"-ish squares.

- Students follow the tutorial to draw themselves with a large circle head. The touching eyes are added, a square mouth and shoulders, and then whatever hair details are desired.
- The drawing is traced with a permanent black marker.
- Students brush water onto the watercolor paper. Squares of tissue are laid on top. More water is brushed on the tissue until it is completely wet. Repeat to fill the entire paper. Let dry for 15 minutes.
- Carefully remove the tissue and dispose of. If the painting is wrinkled, press it between books to flatten.

# Paul Klee SELF PORTRAIT TUTORIAL

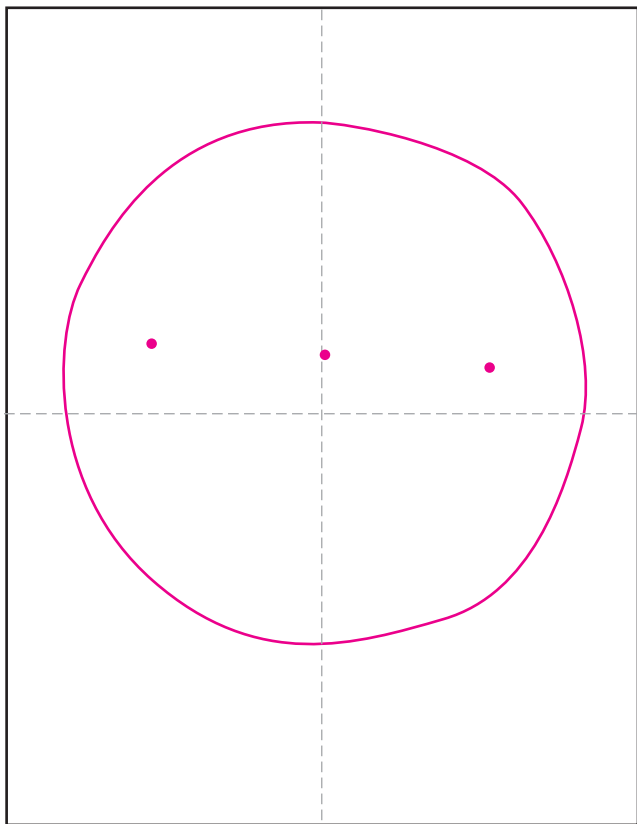

1. Draw or trace a large circle. Make 3 dots for eyes.

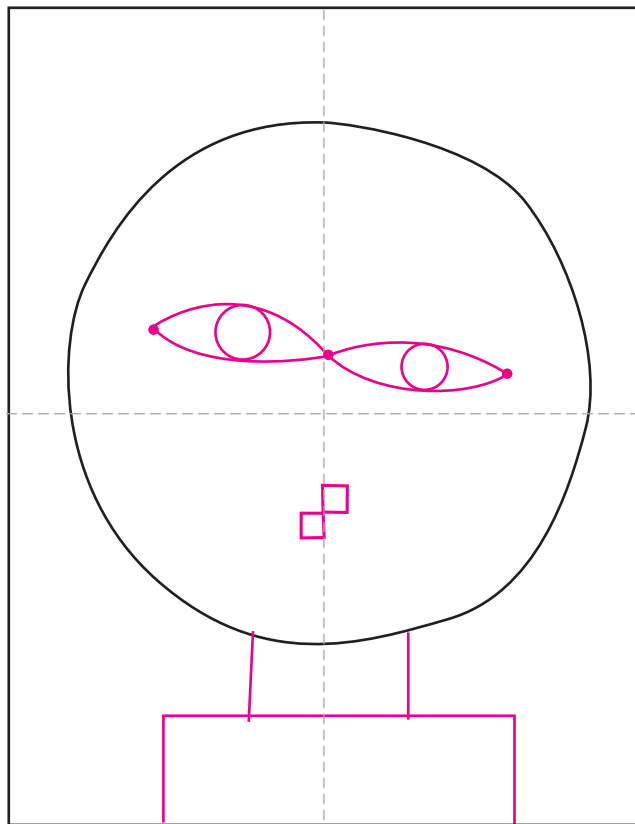

2. Finish eyes, draw square neck, shoulders, mouth.

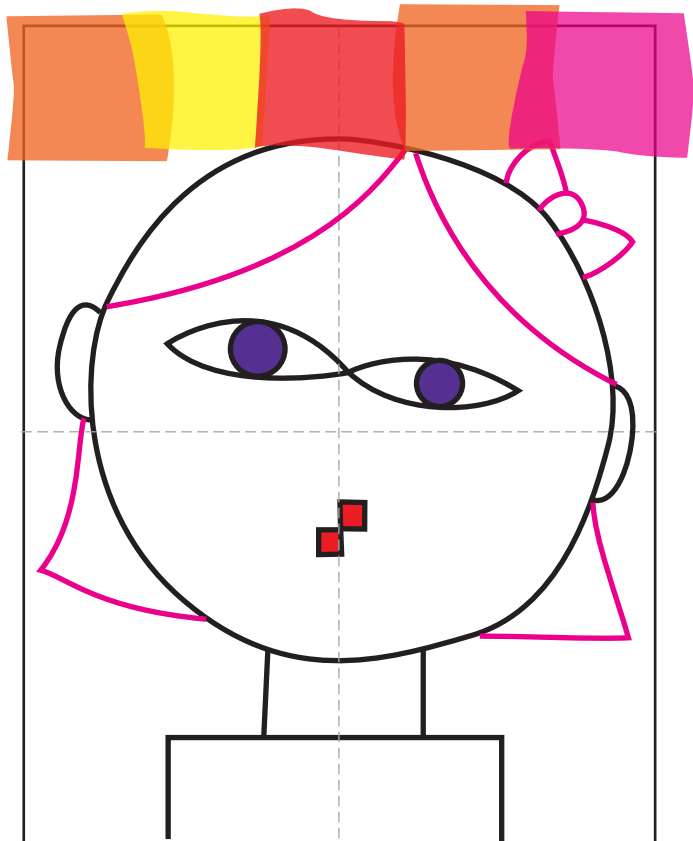

3. Draw your hair. Trace with marker. Color eyes and lips with crayon. Brush with water, apply tissue squares. Repeat until paper is covered. Brush any dry spots.



4. Remove tissue after about 10 minutes. It will brush right off and leave color behind.

Cubism SELF PORTRAIT



# Cubism Self Portrait

Cubism is a style of painting that was developed in the early 1900s, and shows objects from many angles at once. Two main artists, Pablo Picasso and Georges Braque, developed Cubism. They believed that painters should not just present realistic views of subjects. Instead, they wanted to show every part of the whole subject.

Students can follow this simple tutorial to draw a face that half profile and half front view. It's a fun way to draw a literal interpretation of the word "cubism".

## NATIONAL ARTS STANDARDS

VA:Cr1.2.2a Make art or design with various materials and tools to explore personal interests, questions, and curiosity.

## DIRECTIONS

PREP: Print template guide on page 61 for each student.

- Students follow the tutorial to draw a simple cubism style face, with their own hair added. The emphasis is on keeping the drawing very simple. No fancy eyes or clothes are needed.
- The drawing is traced with a thick black marker.
- The drawing is colored with markers or crayons or pastels. The goal is to use unusual colors - the brighter and bolder, the better!



## MATERIALS

- White drawing paper
  - Black permanent marker, chisel tip
  - Crayons or markers
- (I used Creativity Street Glide-On Tempera Color Sticks)

# Cubism SELF PORTRAIT TUTORIAL



Supplies: Markers and or oil pastels

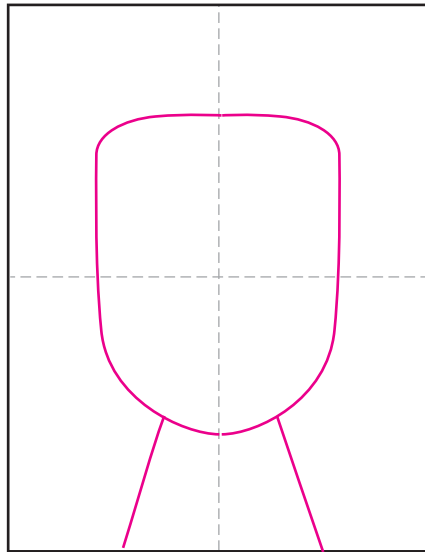

1. Fold for guide lines. Draw head and neck.

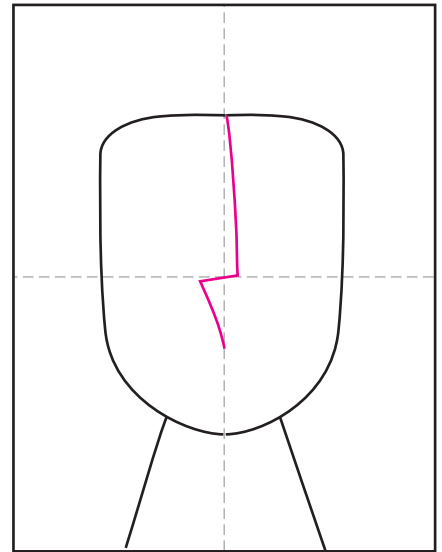

2. Start the profile nose.

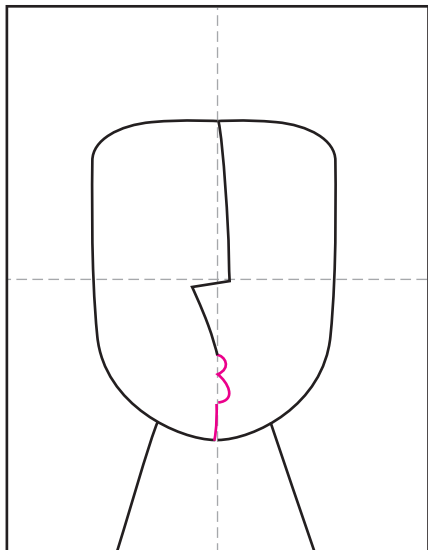

3. Add the profile mouth and chin.

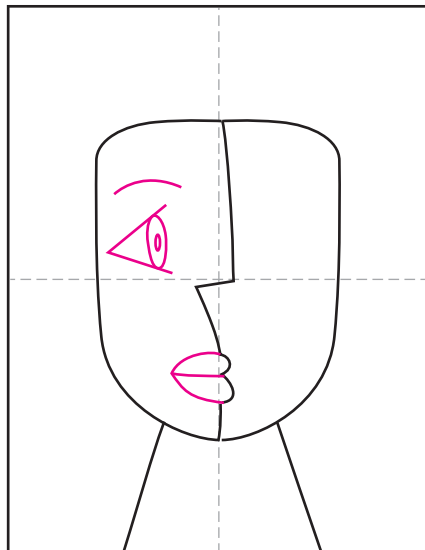

4. Draw the left profile face.

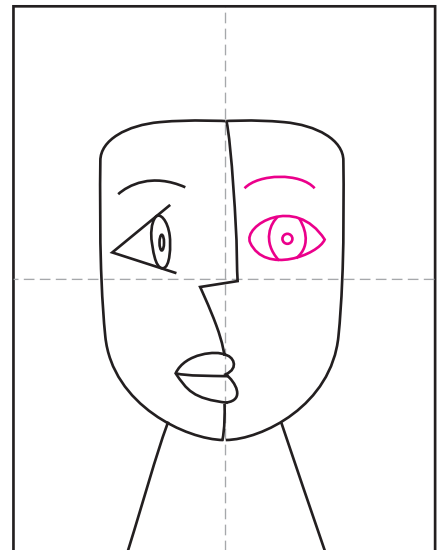

5. Draw direct looking right eye.

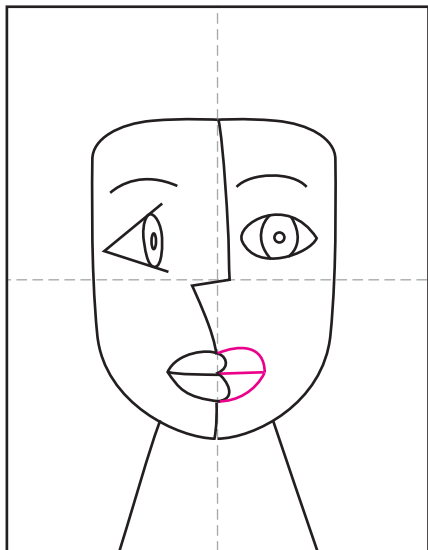

6. Add right lips.

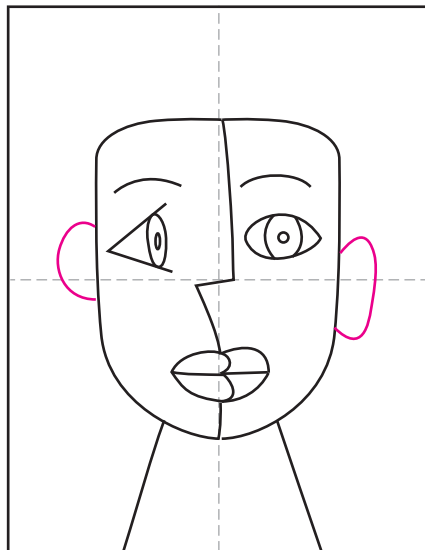

7. Add two ears, they needn't match.

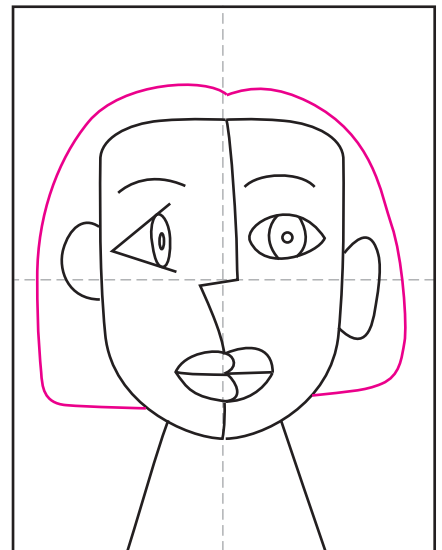

8. Finish with hair. Trace and color.



Statue of Liberty SELF PORTRAIT



## Statue of Liberty Self Portrait

Students learning about United States symbols, such as the Statue of Liberty, can draw themselves with a crown and fireworks, just like what is seen in the New York Harbor every 4th of July.

My tutorial will walk students through drawing their head under a crown, and then tips on making colorful star painting in the background.

### NATIONAL ARTS STANDARDS

VA:Cr1.2.2a Make art or design with various materials and tools to explore personal interests, questions, and curiosity.

### DIRECTIONS

PREP: Print the grid on page 61 or draw the guide lines in pencil on the paper. This really help young students draw large and fill the paper.

- Direct the students or have them follow the Statue of Liberty Tutorial themselves.
- The drawing is traced with a black marker.
- The entire face is painted a light copper green.
- Students use crayons to draw stars in the background.
- Black watercolor is used to paint the sky.



### MATERIALS

- Watercolor paper, 9" x 12"
- Black marker
- Crayons
- Watercolor paint (I like the liquid Sargeant® brand)

# Statue of Liberty SELF PORTRAIT TUTORIAL



Supplies: Marker, crayons, watercolor paint

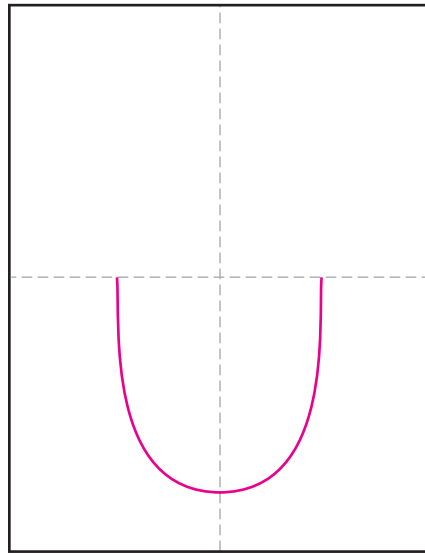

1. Make guide lines. Draw a "U".

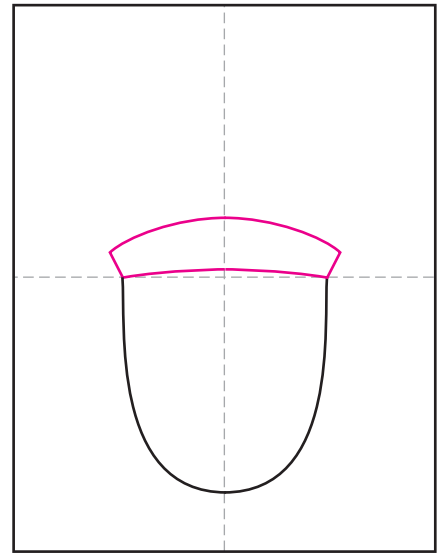

2. Draw the crown base.

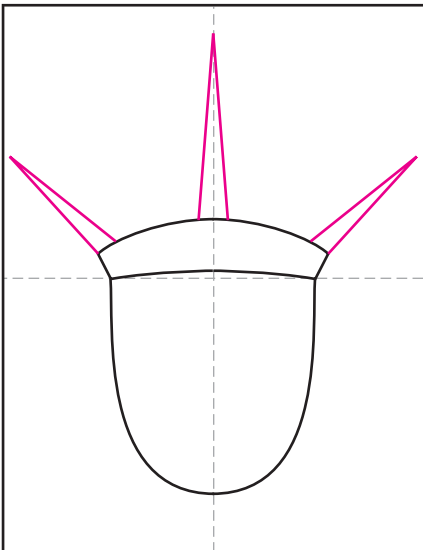

3. Draw three crown spikes.

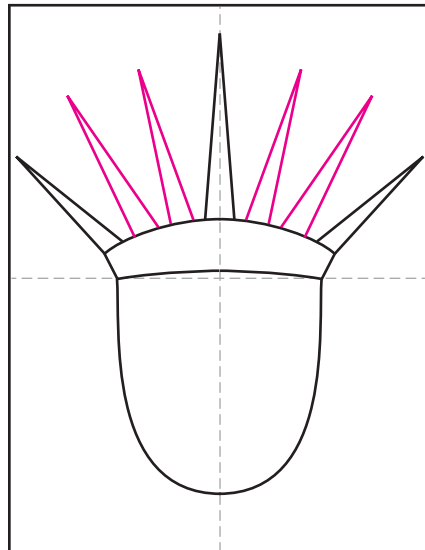

4. Fill in remaining crown spikes.

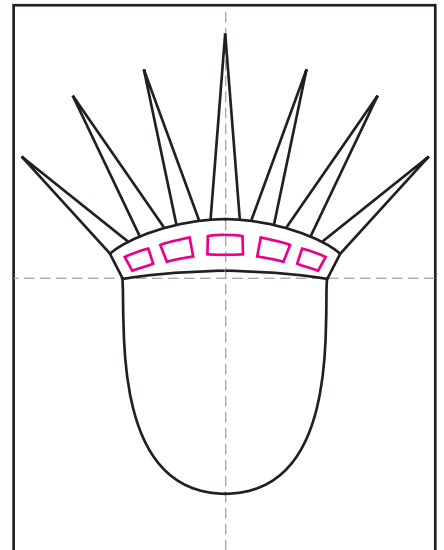

5. Draw the crown windows.

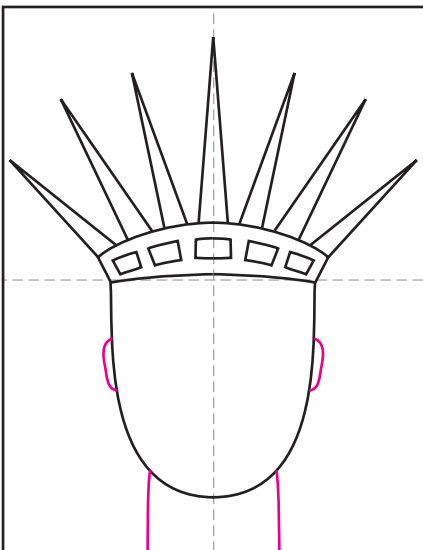

6. Add ears and neck.

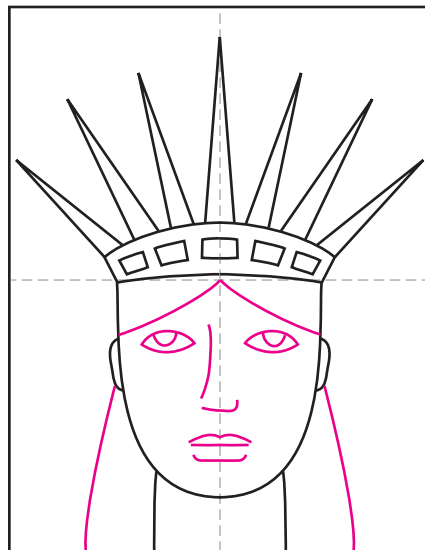

7. Finish with face and hair. Trace all with permanent black marker.



8. Draw crayon stars. Paint background with black watercolor paint.

*Big Face* SELF PORTRAIT



# Big Face Self Portrait

Here's a drawing that is guaranteed to fill the paper. Students are directed to make their lines touch the edge so you end up with some very large and interesting works of art.

Any kind of media could be used for this, but I find it perfect for a crayon resist as the large sections of the face are so easy and fun to fill with all kinds of patterns. Some of my all time favorite ones have been created by kinders, so it's easy to do.

## NATIONAL ARTS STANDARDS

VA:Cr1.2.2a Make art or design with various materials and tools to explore personal interests, questions, and curiosity.

## DIRECTIONS

- Direct the students or have them follow the tutorial on the following page.
- Students trace the drawing with a black marker.
- Patterns are drawn with crayon on the large areas.
- Fill all the sections with liquid watercolor paint.



## MATERIALS

- Watercolor paper, 9" x 12"
- Black marker
- Crayons
- Liquid watercolor paint

# Big Face SELF PORTRAIT TUTORIAL



Supplies: Marker, crayons, liquid watercolor paint, watercolor paper

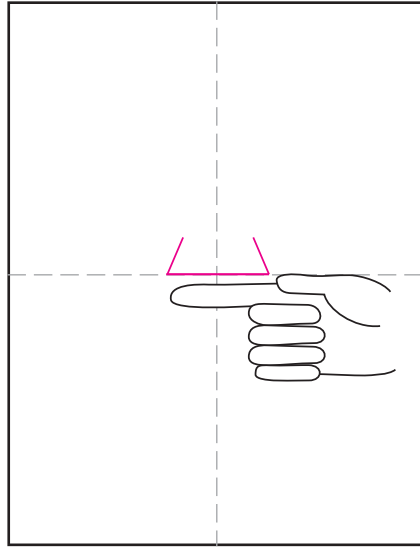

1. Make guide lines. Start the nose.

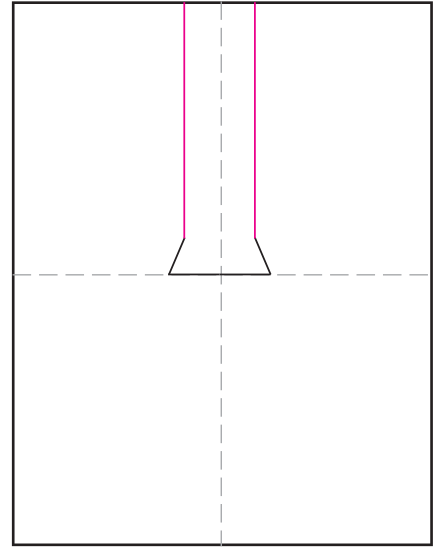

2. Add two lines going up.

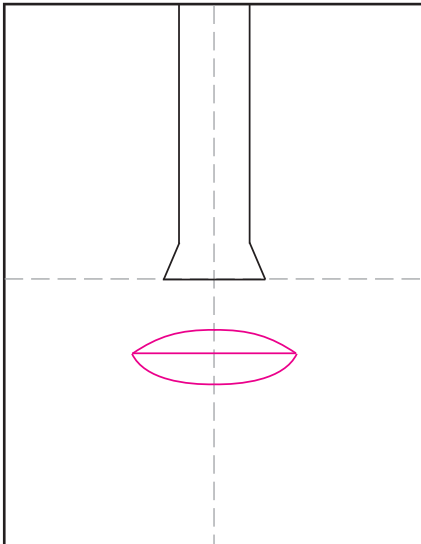

3. Draw a mouth.

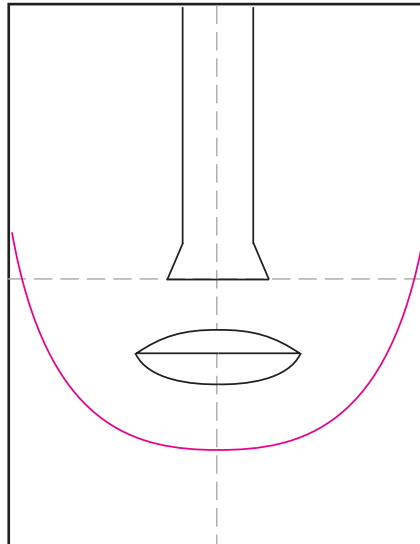

4. Draw the chin.

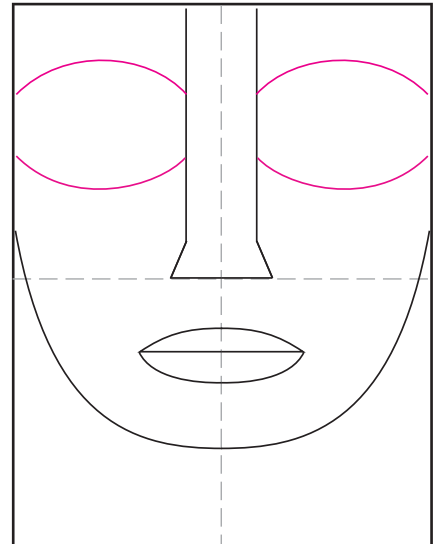

5. Draw four curved lines.

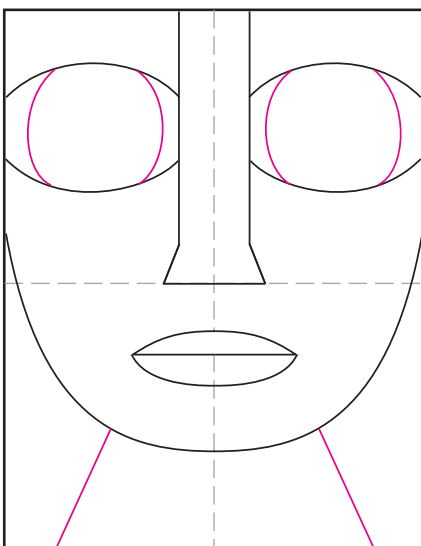

6. Finish the eyes. Add the neck.

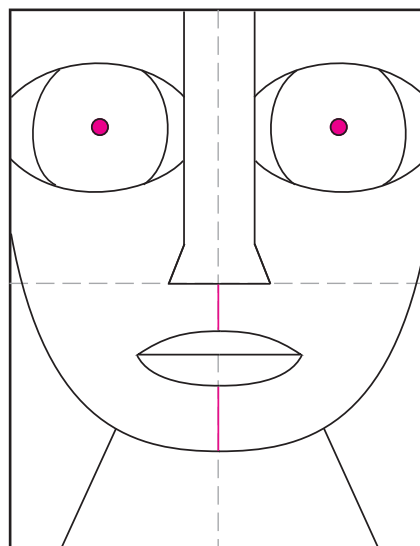

7. Add center of eyes and mouth lines.

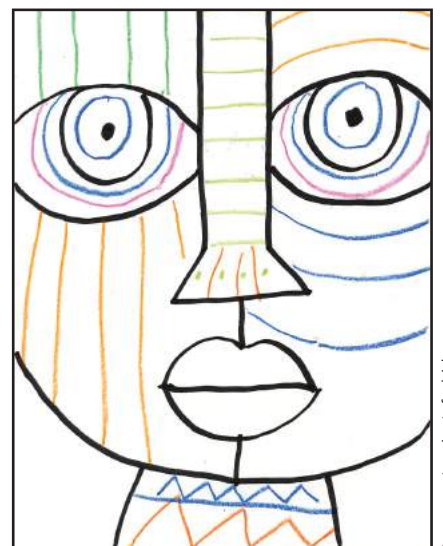

8. Trace, add crayon patterns, paint.

Hundertwasser SELF PORTRAIT



# Hundertwasser Self Portrait

Friedensreich Hundertwasser, born in Austria in 1928, was one of the most important artists and architects of the 20th century.

Hundertwasser produced many different types of works of art (ranging from paintings, postage stamps, clothes, flags). His work often included bright colours and natural, organic forms. He believed that people were not happy when they lost their connection with nature.

This self portrait lesson uses some of his trademark features: eyes that touch each other, mouths with pointy lips and simplified body shapes.

## NATIONAL ARTS STANDARDS

VA:Cr1.2.2a Make art or design with various materials and tools to explore personal interests, questions, and curiosity.

## DIRECTIONS

PREP: Print the template page with the double light border lines on page 18 for each student.

- Direct the students or have them follow the tutorial on the following pages.
- Students trace the drawing with a black marker.
- The drawing is colored with pencil crayons.



## MATERIALS

- White drawing paper, 8.5" x 11"
- Black marker
- Crayons or pencil crayons



# Hundertwasser SELF PORTRAIT TUTORIAL



Supplies: Marker, pencil crayons

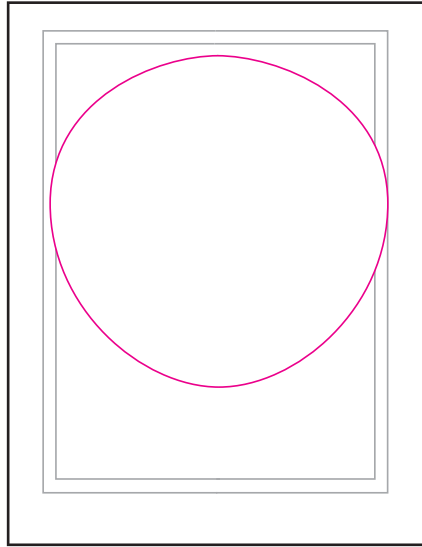

1. Draw a circle that touches the border as shown.

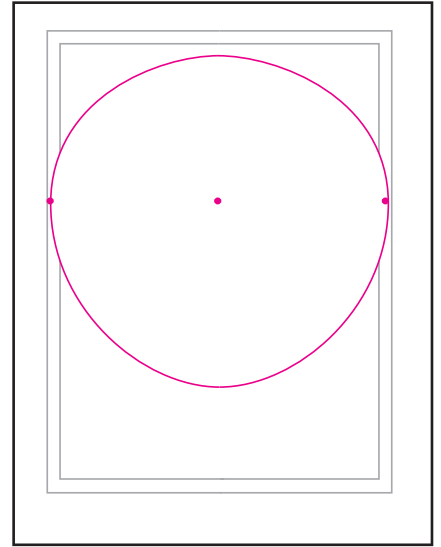

2. Make three dots for the eyes.

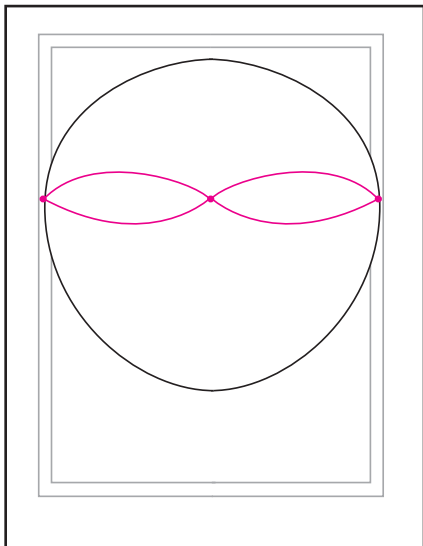

2. Connect dots for eyes.

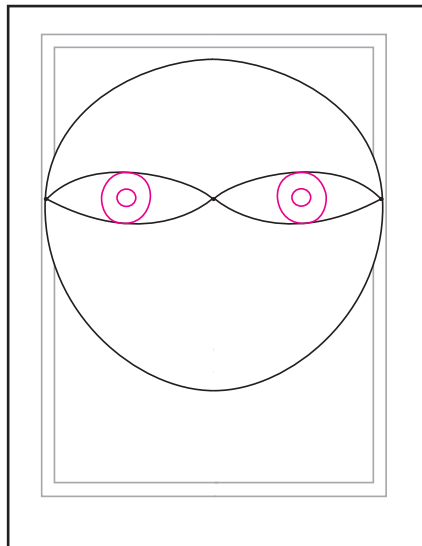

3. Draw circles inside eyes.

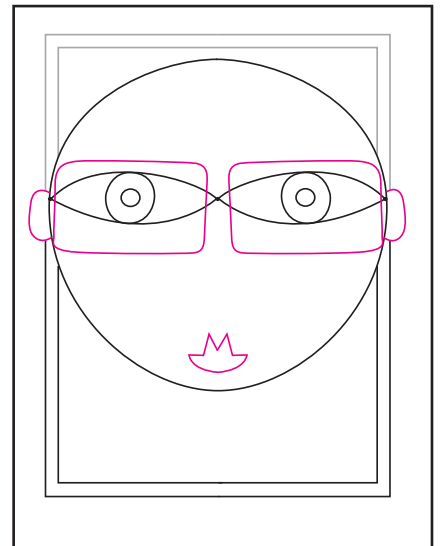

4. Finish face, add ears. Hundertwasser liked to draw a mouth as shown.

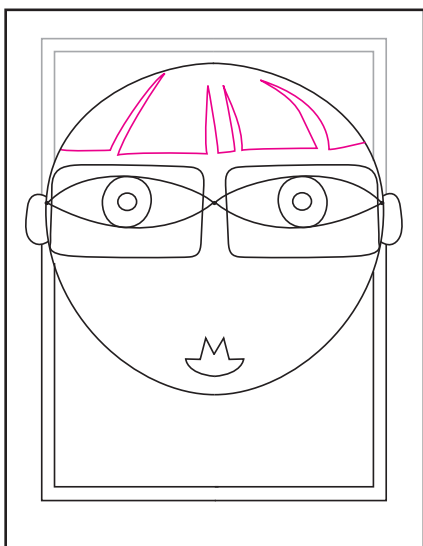

5. Draw forehead hairline as needed.

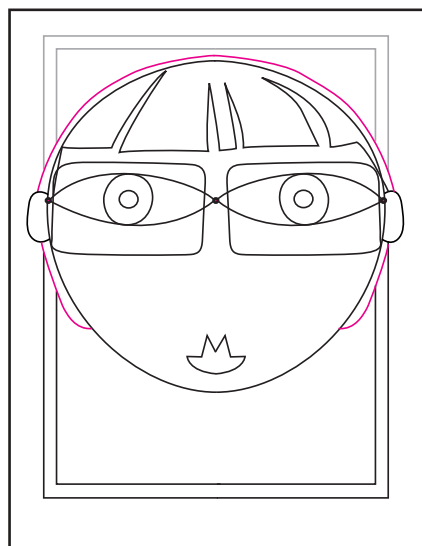

6. Draw outer hair line as needed.

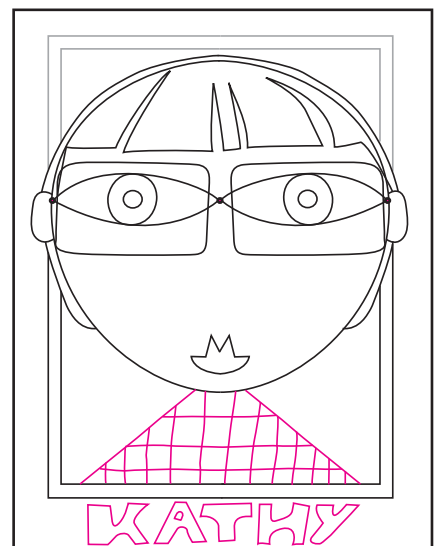

7. Draw simple triangle shoulders. Add your name below.

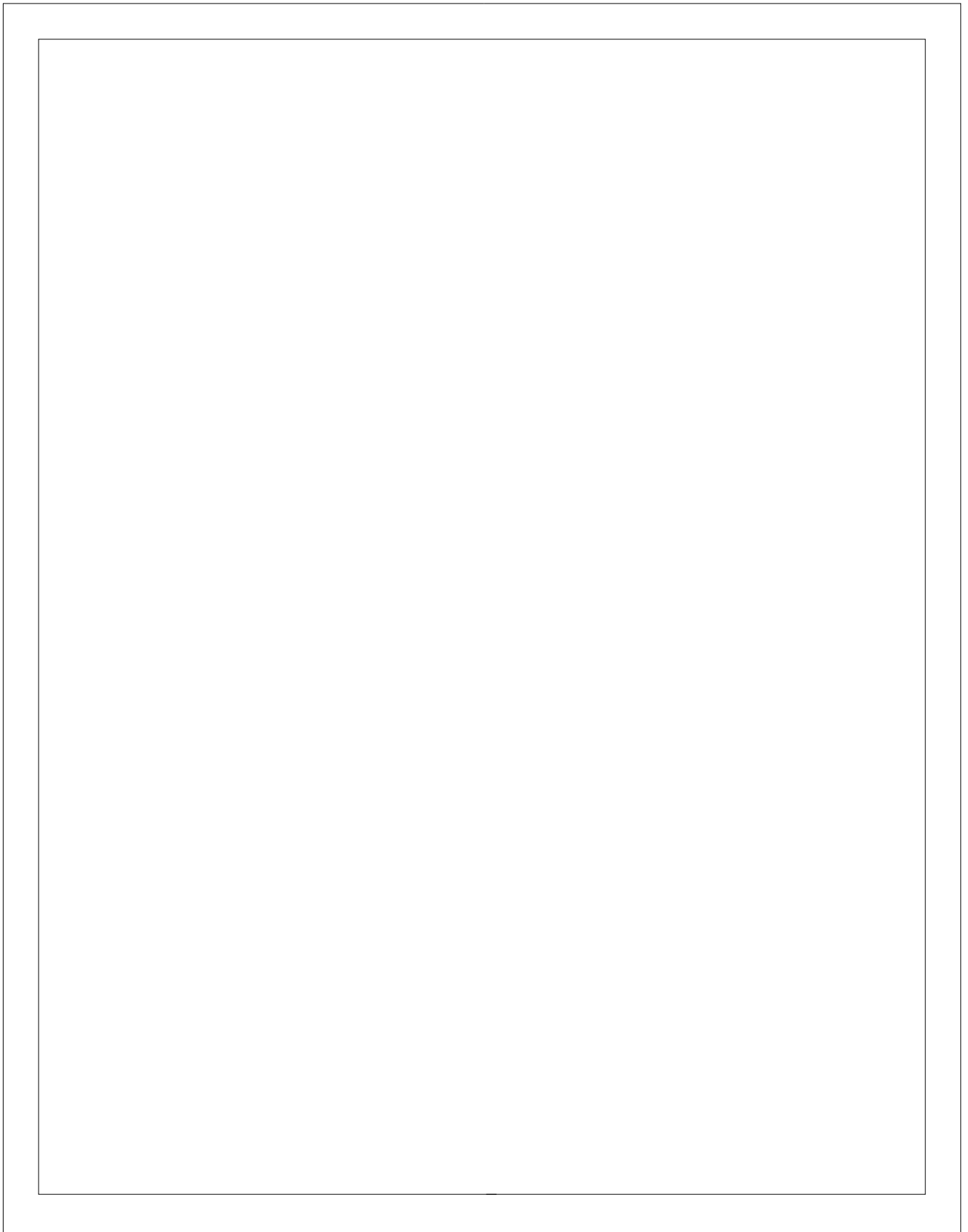

# Sophia

New shirt  
from my  
vacation.

My sister's  
bow

Birth day  
bracelet

skinned  
knee

My  
favorite  
shorts

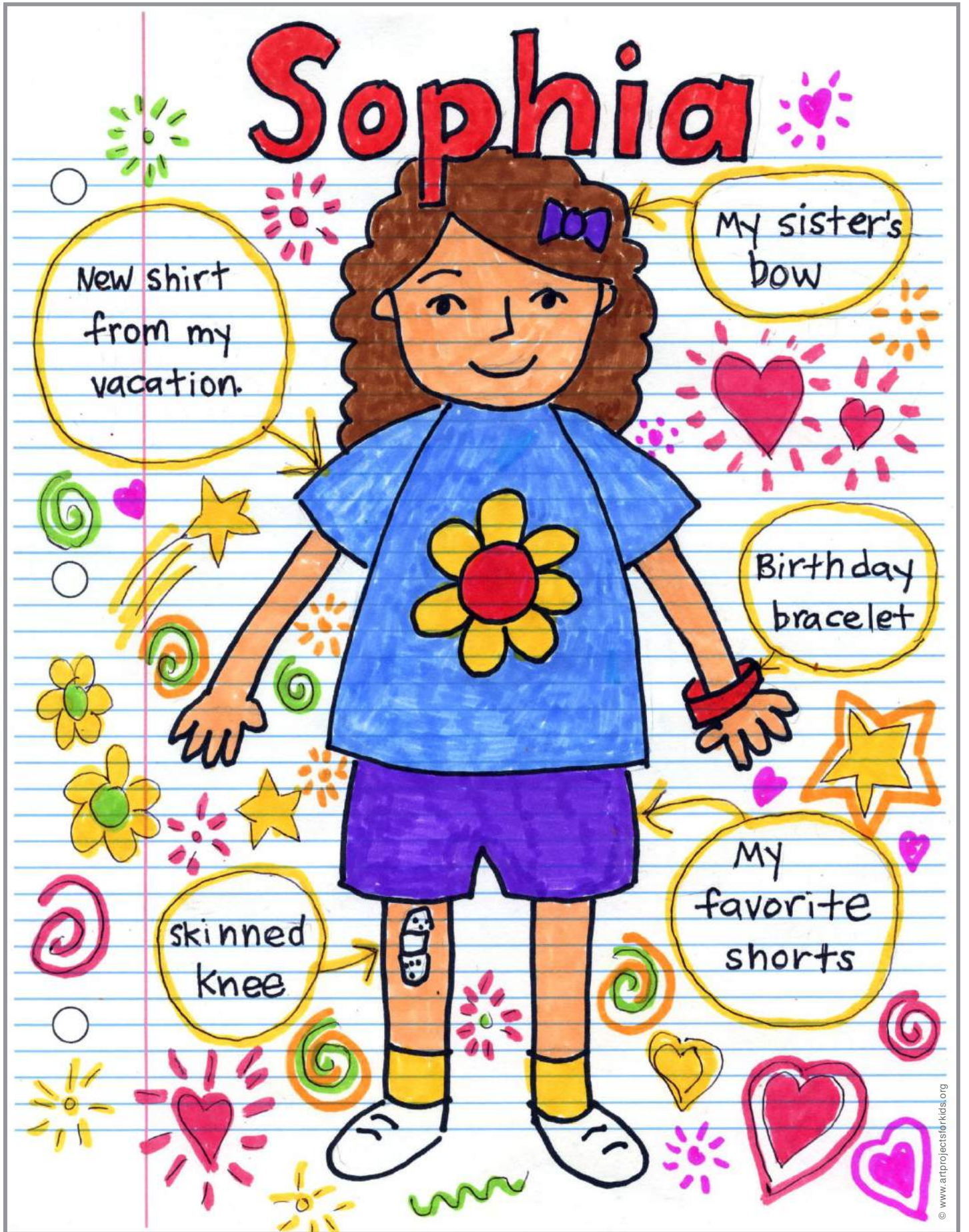

## Doodle Self Portrait

The goal of this project is for students to share five things about themselves through their artwork.

Students make a simple self portrait drawing and label things that make them unique. A drawing paper background gives them a horizontal guide for body symmetry and provides assistance in placement of sentences.

When the drawing and writing is complete, doodles are added to fill in the background. It's an easy way for students to learn to fill their paper, and spend the extra time it takes to make a colorful work of art.

### COMMON CORE WRITING STANDARDS

Production and Distribution of Writing:

CCSS.ELA-LITERACY.W.1.5

With guidance and support from adults, focus on a topic, respond to questions and suggestions from peers, and add details to strengthen writing as needed.

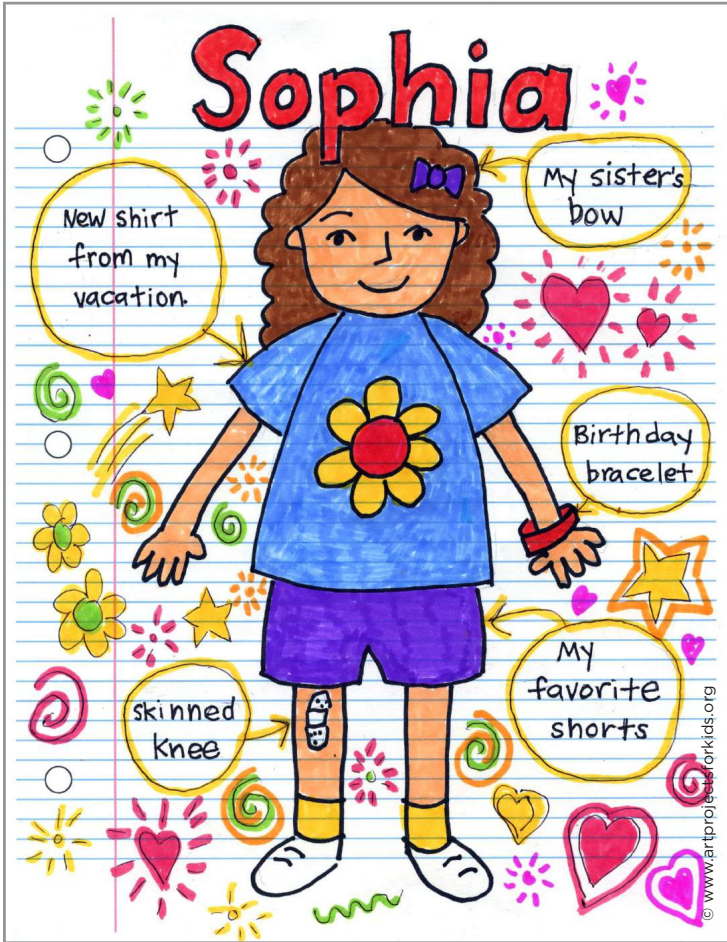

### MATERIALS

- White drawing or other heavy paper, 8.5" x 11"
- Thin black markers
- Markers (I prefer the Stabilo® Power Markers)

### DIRECTIONS

PREP: Print School Paper art on page 22 to heavy paper.

- Students follow my tutorial to draw themselves, filling up the space with the blue lines.
- The drawing with a black marker.
- At least five label sentences are written with a pencil, then circled, and traced.
- Students color their body, and add lots of simple doodle shapes (hearts, stars, swirls) to the background to make it full of color.

# Doodle SELF PORTRAIT TUTORIAL

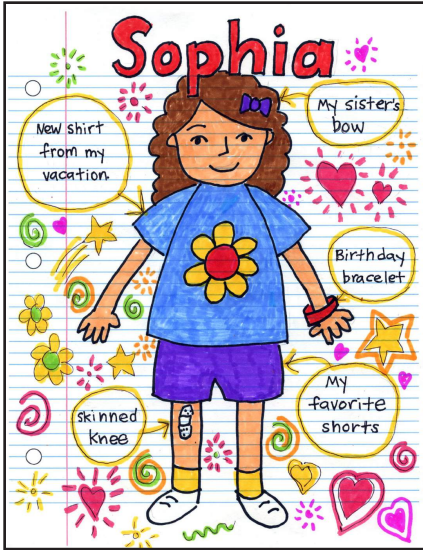

Supplies: Markers, I like Stabilo®

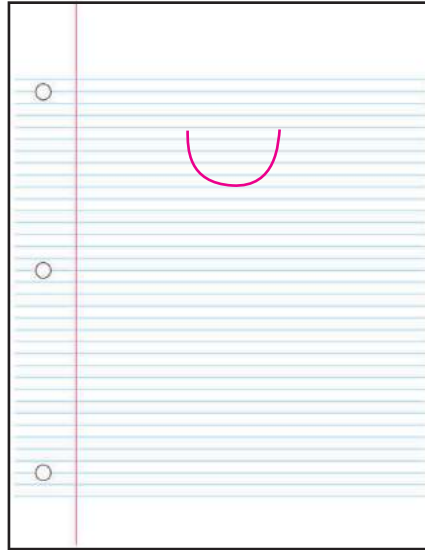

1. Start the head with a U shape.

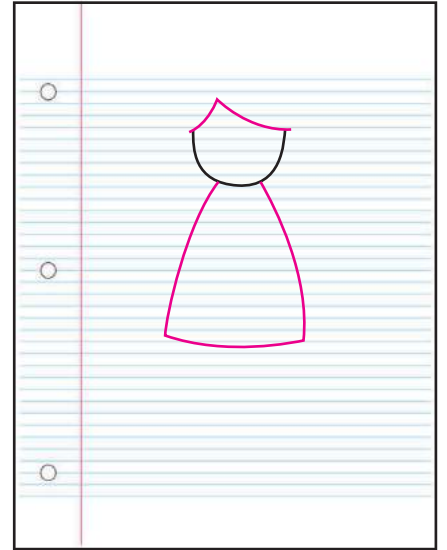

2. Add hair line. Start the body.

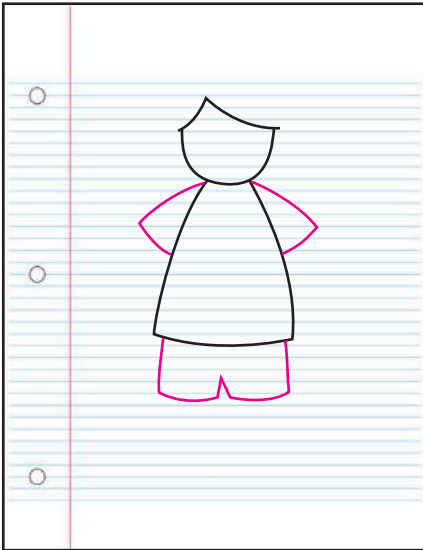

3. Add the sleeves and pants.

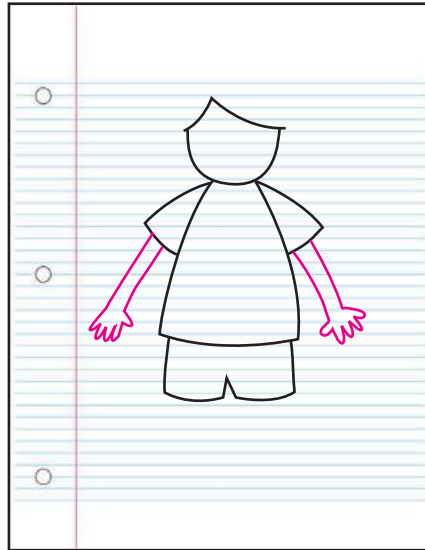

4. Draw two matching arms.

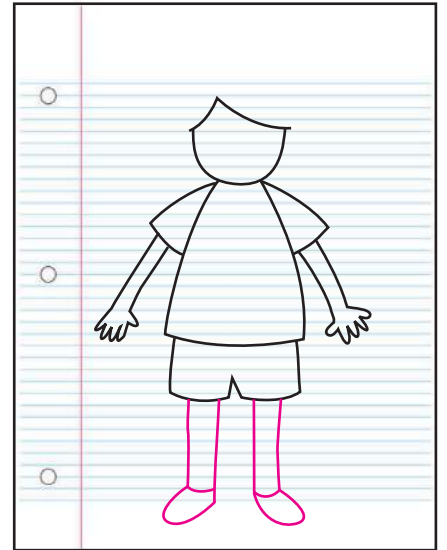

5. Draw two matching legs, feet.

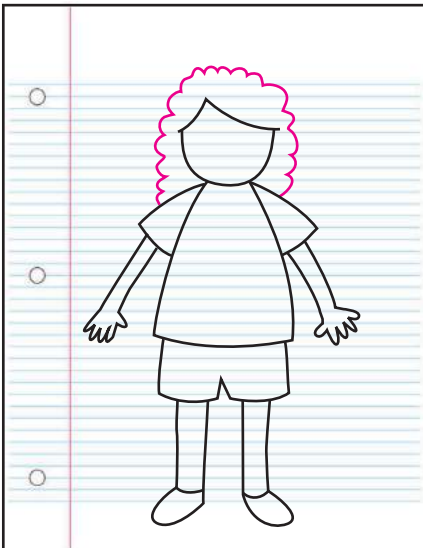

6. Finish head with hair.

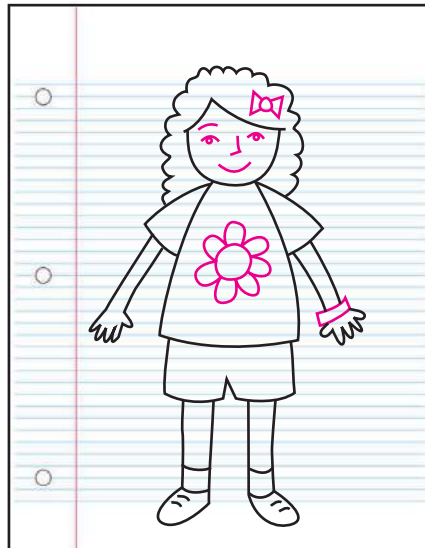

7. Add face and details.

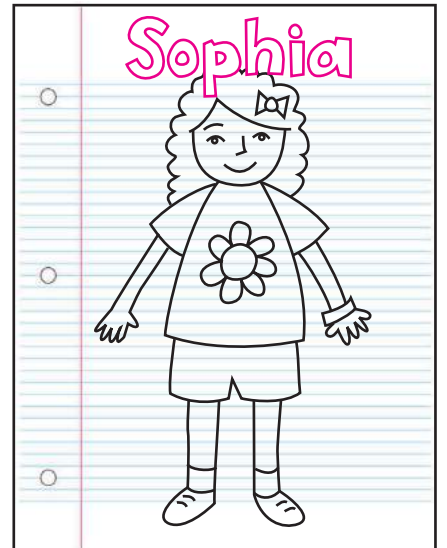

8. Draw your name in block letters. Trace, color and add lots of doodles.



LEGO SELF PORTRAIT

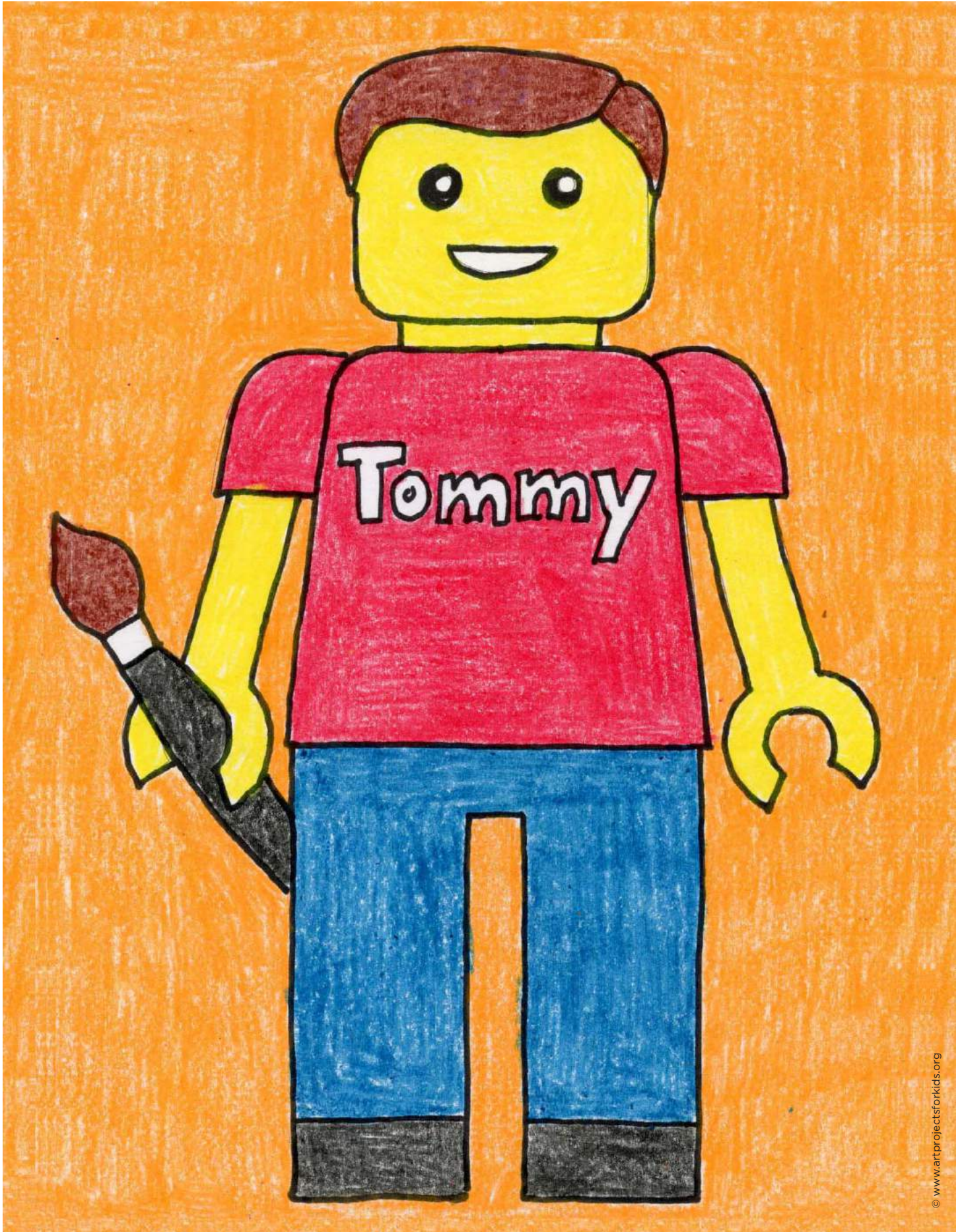

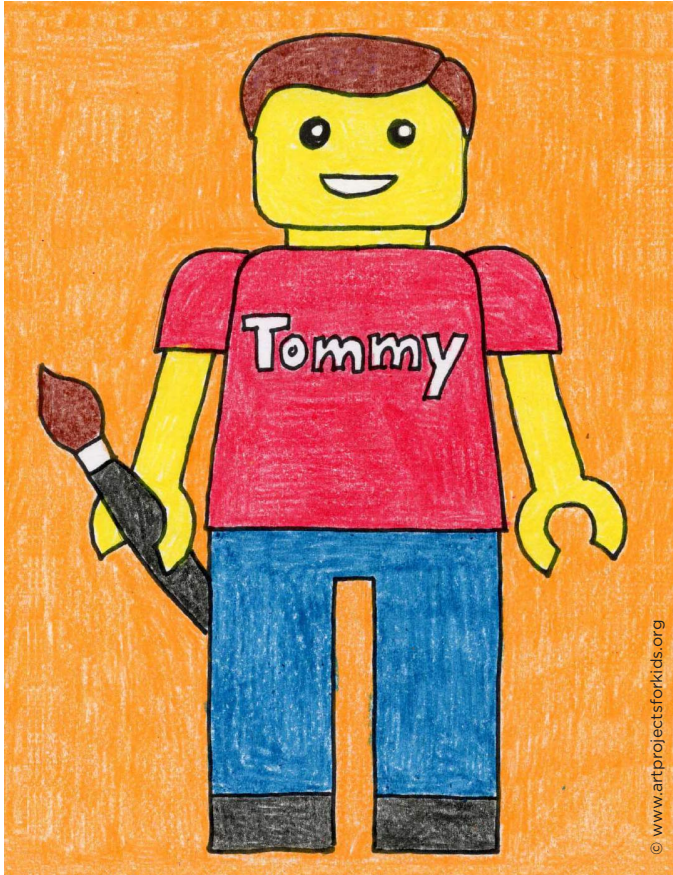

## Lego Self Portrait

The popularity of Legos and their simple shapes really lend themselves to some fun art projects for kids.

I've made a tutorial to help students to draw their own block shape body, so they can customize it any way they'd like. Some straight lines, geometric shapes and rounded corners are all it takes.

For a final touch, adding a personal item in one hand will also tell a lot about what the students are interested in.

### NATIONAL ARTS STANDARDS

VA:Cr1.1.5a Combine ideas to generate an innovative idea for art-making.

### DIRECTIONS

PREP: Print template shown on page 26 or have students fold their paper three times to create guide lines shown.

- Students draw a Lego body by following the tutorial.
- When complete, the hair and clothes are customized to reflect what they look like and what they wear. Their name is added to their clothing.
- A personal item is added to at least one hand, something that describes more of what their interests are.
- The drawing is traced with a black marker.
- The drawing is colored heavily with crayons.

### MATERIALS

- White drawing paper, 8.5" x 11"
- Black marker
- Crayons



# LEGO SELF PORTRAIT TUTORIAL

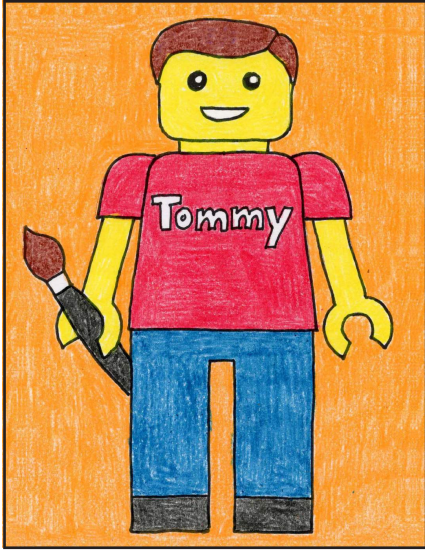

Supplies: Black marker, crayons

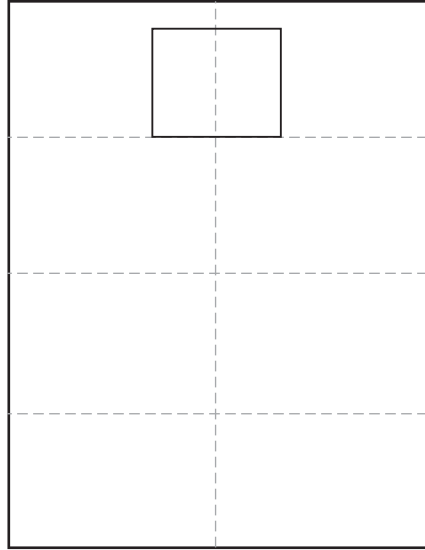

1. Fold or print guide lines. Draw head.

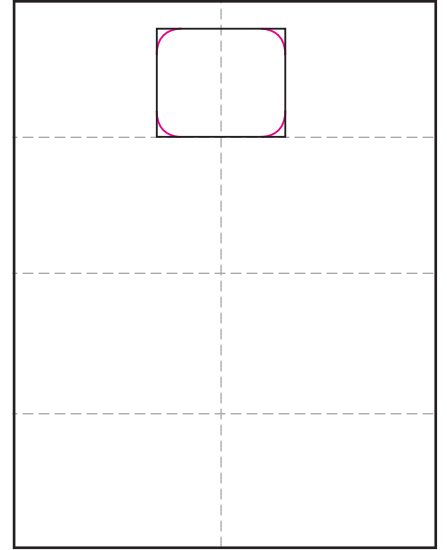

2. Round the corners, erase originals.

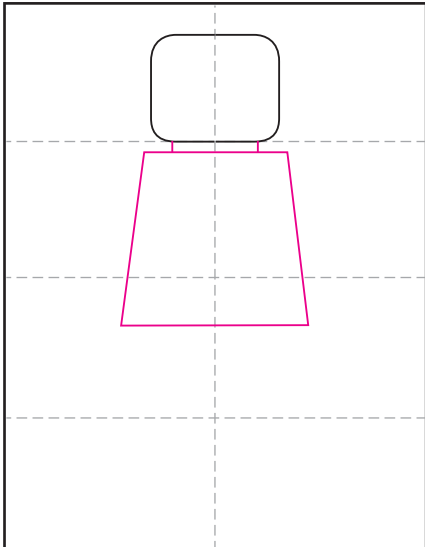

3. Draw neck and torso.

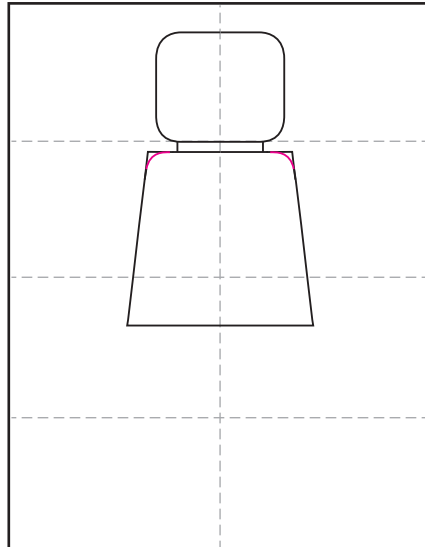

4. Round shoulder corners.

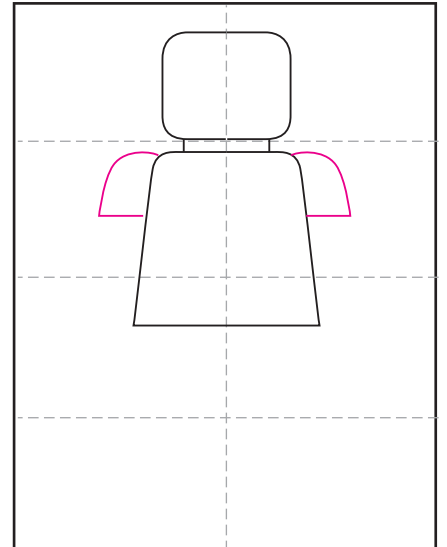

5. Draw two sleeves.

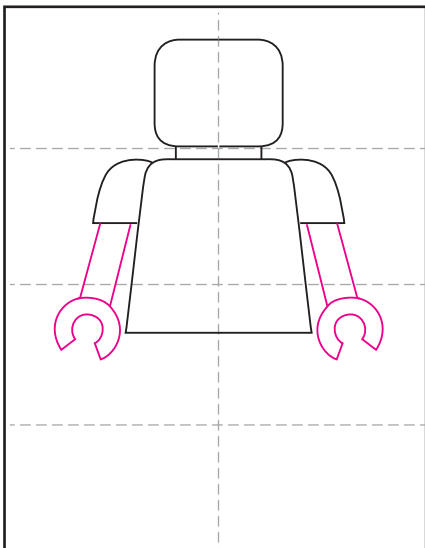

6. Draw two arms and circle hands.

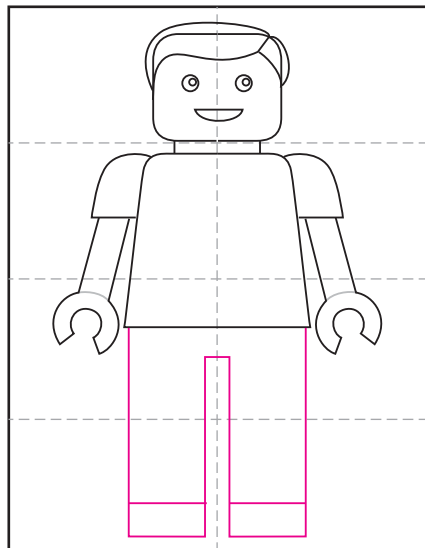

7. Draw two symmetrical legs.

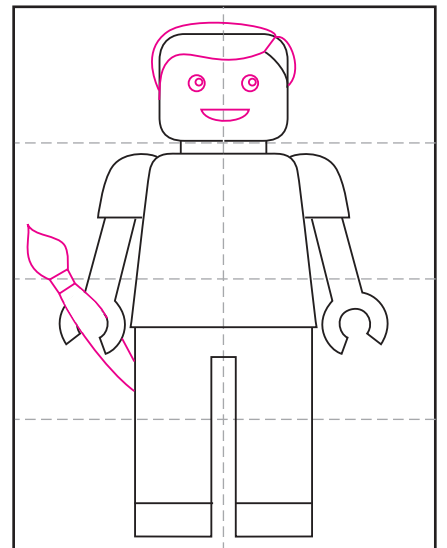

8. Finish with hair, face, personal item.



# Sunglasses SELF PORTRAIT



# Sunglass Self Portrait

This is another drawing project that forces students to work larger than they normally do, without creating cookie cutter results. Students can draw in the glasses the things they saw on a summer break or even just a long weekend.

## NATIONAL ARTS STANDARDS

VA:Cr1.1.3a Elaborate on an imaginative idea.

## MATERIALS

- White drawing paper, 9" x 12"
- Black marker
- Crayons (with lots of skin colors)

## DIRECTIONS

PREP: Print a dashed line glass template for each student. If using 9" x 12" paper, increase size 110%.

- Students trace the glasses and then draw their face according to the tutorial.
- The drawing is traced with a marker.
- The drawing is colored with crayons or oil pastels.



TIP: Mistakes to avoid. Students need only note where their cheeks should touch their glasses avoid either from happening.

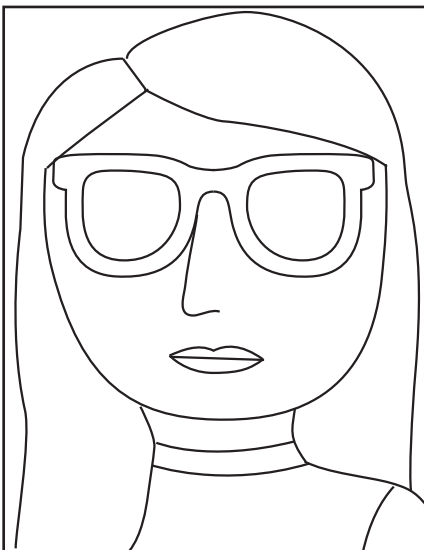

This face is too wide, it's wider than the glasses!

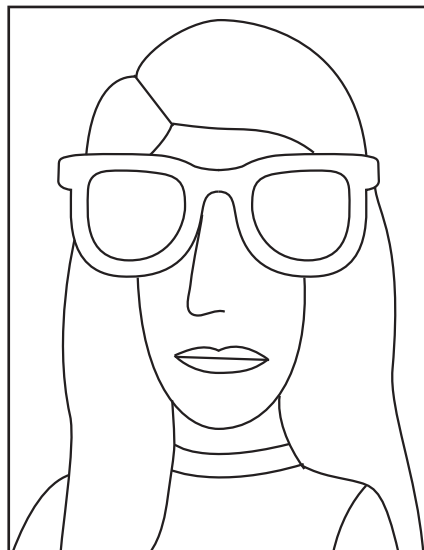

This face is too narrow.

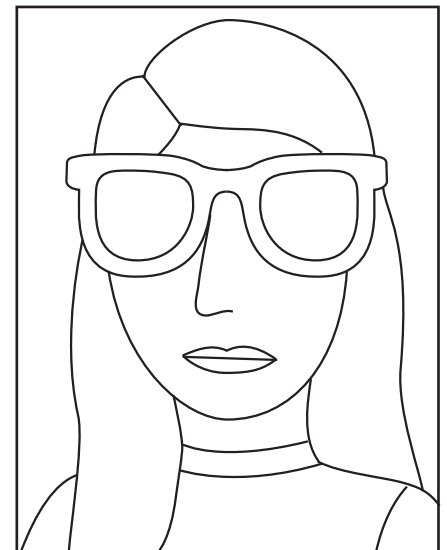

This one is just right.

# Sun Glasses SELF PORTRAIT TUTORIAL



Supplies: Marker, crayons

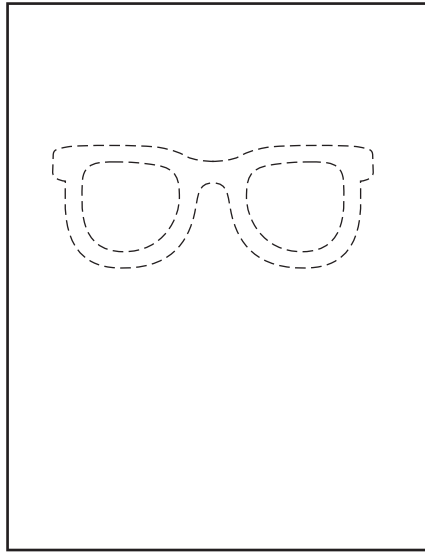

1. Trace the glasses lines.

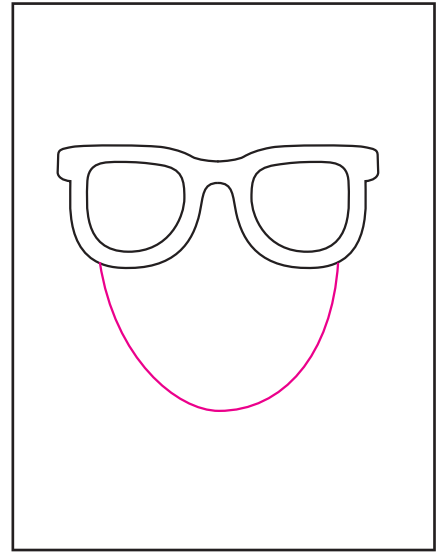

2. Start the bottom face drawing.

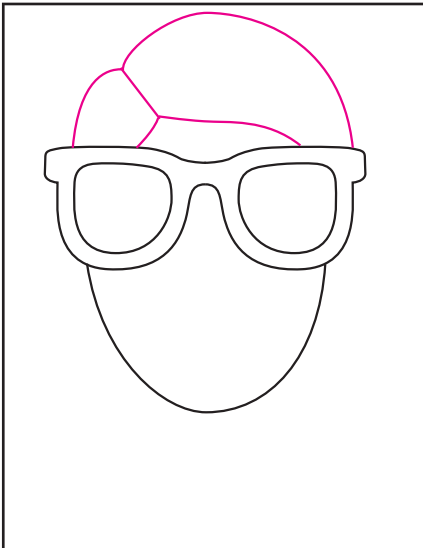

3. The top head with hair is added.

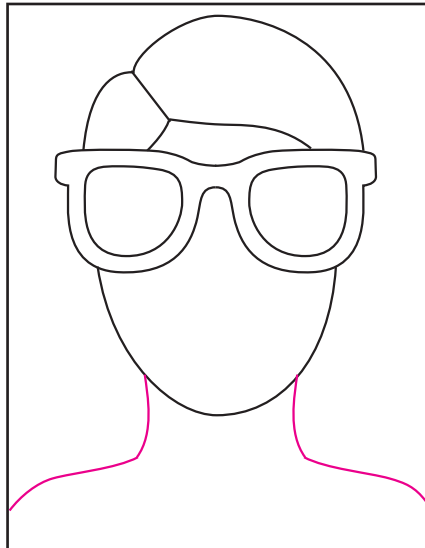

4. Draw the neck and shoulders.

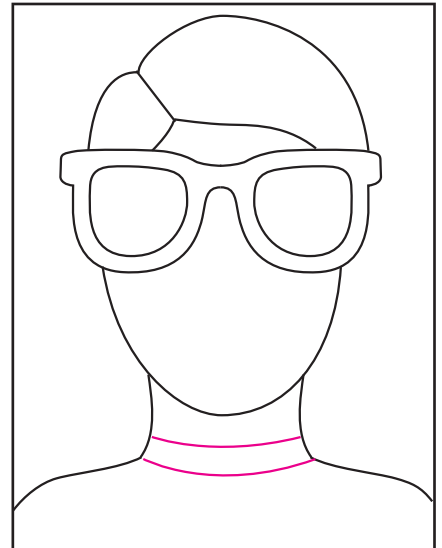

5. Add a neckline as desired.

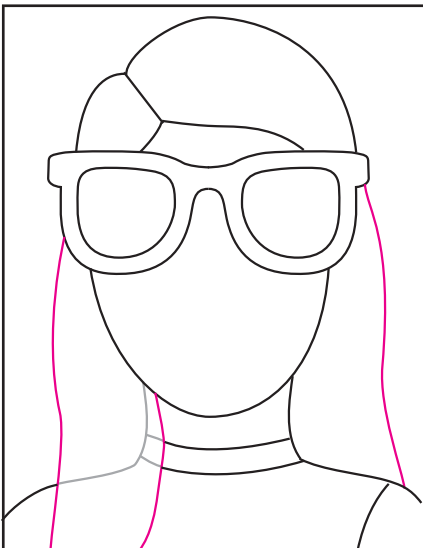

6. If longer hair is needed, it's added during this step.

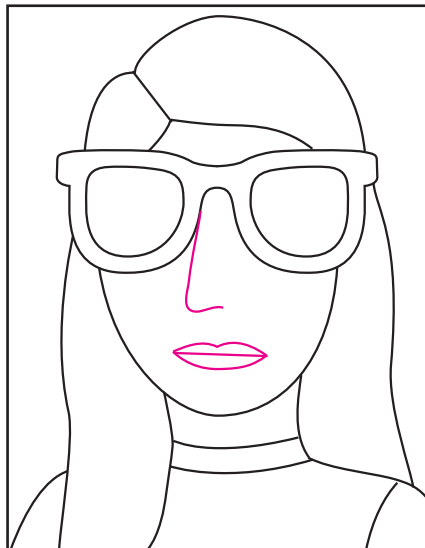

7. Draw a nose and mouth.

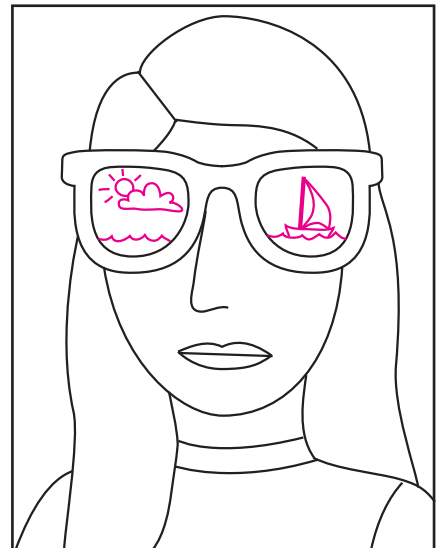

8. Draw inside your glasses. All the art is traced and colored.

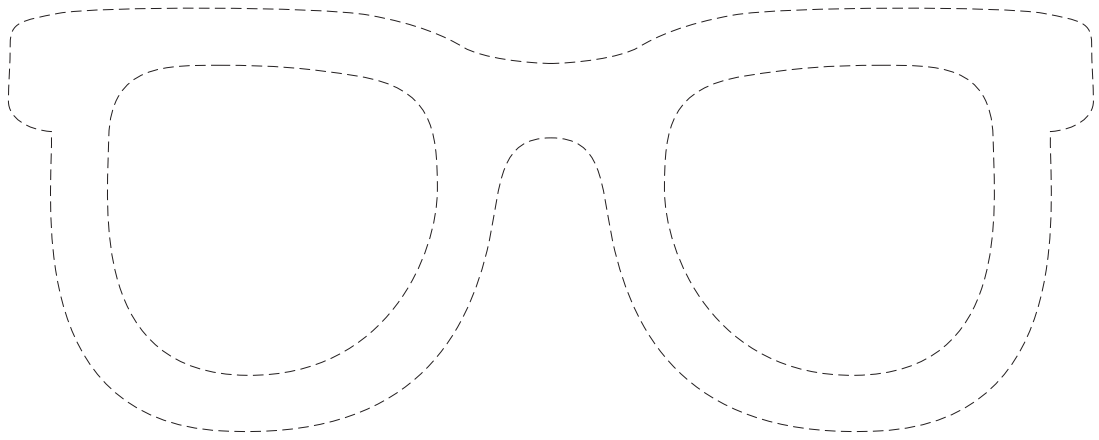

Modigliani SELF PORTRAIT

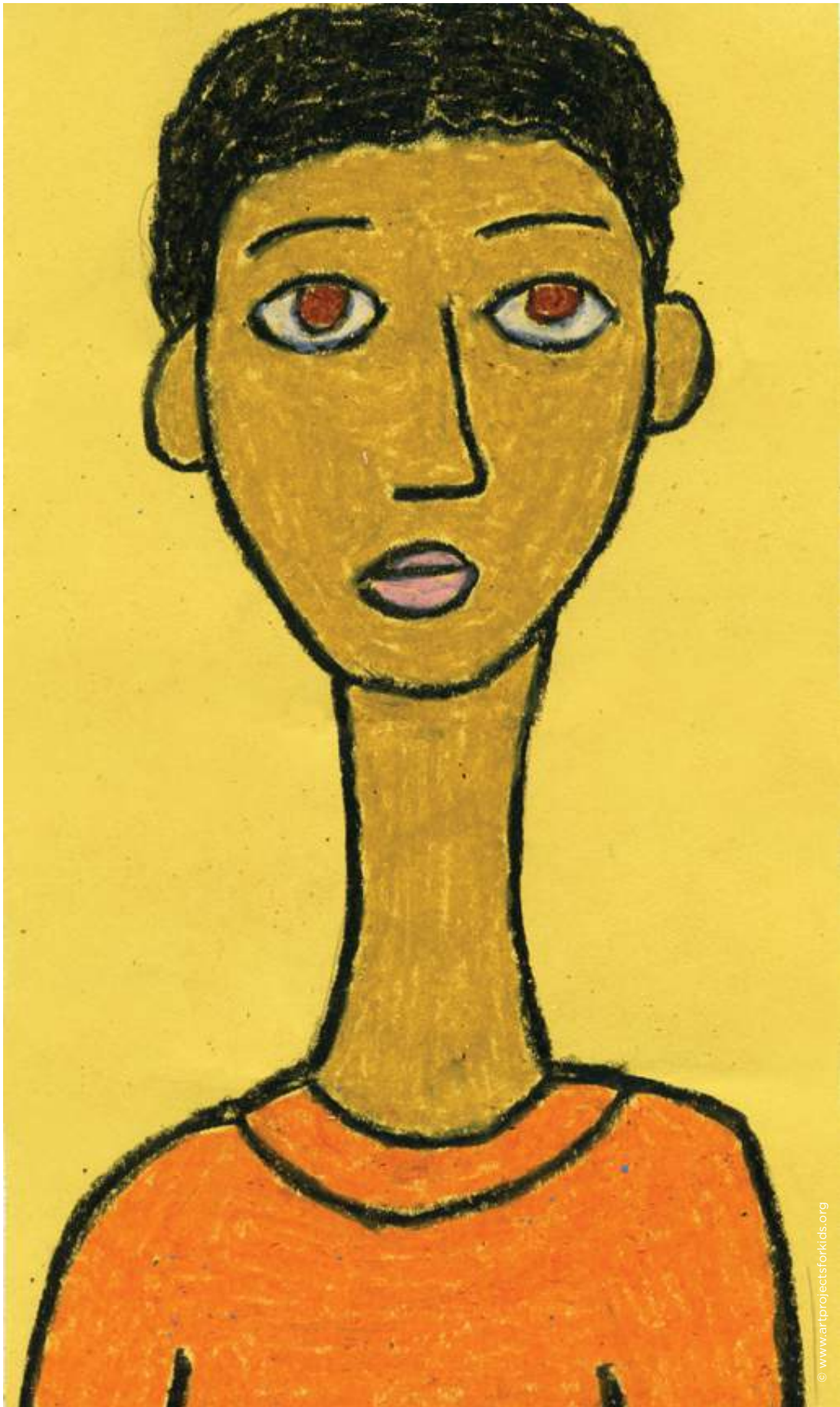

Modigliani SELF PORTRAIT





# Modigliani Self Portrait

Amadeus Modigliani lived in Paris in the early 1900s and was known for painting portraits with elongated features. This project actually asks students to exaggerate the process, but in a fun way that often frees them up to make expressive self portraits.

## NATIONAL ARTS STANDARDS

VA:Cr1.2.2a Make art or design with various materials and tools to explore personal interests, questions, and curiosity.

## MATERIALS

- Assorted construction paper, 9" x 12"
- Oil pastels

## DIRECTIONS

PREP: Cut all construction paper to 9" x 12".

- Students fold the paper in half 3 times, as shown in the tutorial.
- The self portrait is drawn, according to the tutorial, taking note about the unusual proportions of the neck and facial features.
- The drawing is traced with a black oil pastel.
- The drawing is traced AGAIN in black to make extra thick lines.
- The drawing is filled in with oil pastel colors.

TIP: My first choice for this project is for students to draw on black paper, and then color the background. It makes for a very rich look.

However, if your black paper is particularly dark, it may be hard to see the pastel. A quick test on black is advised before you start.



# Modigliani SELF PORTRAIT TUTORIAL

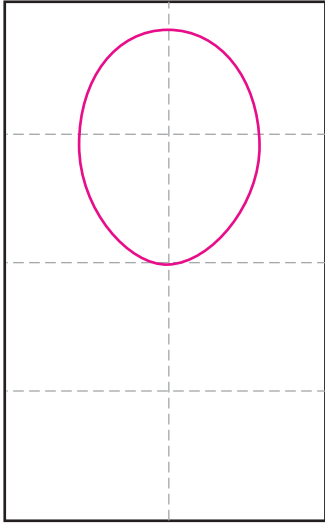

1. Fold 7" x 12" paper in half 3 times to create. Draw an oval to fill top 2 rows.

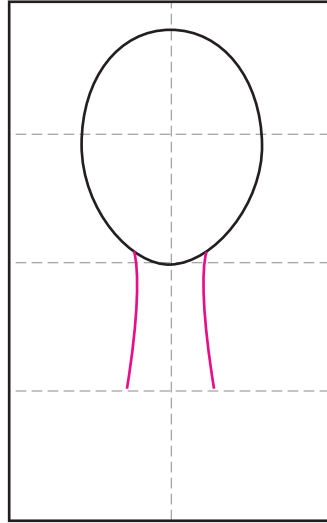

2. Draw a neck that fills the third row down. It's going to look long, don't worry!

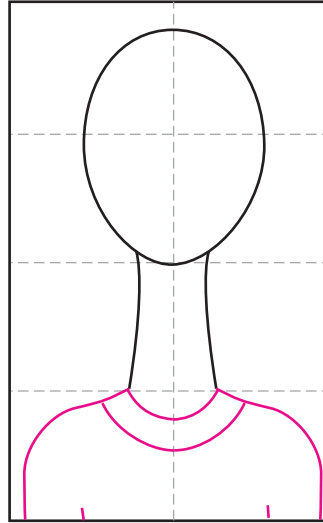

3. Draw the neckline and shoulders. Add lines to show where the arms are starting.

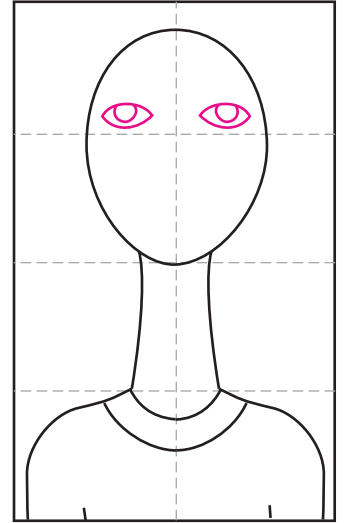

4. Draw the eyes ABOVE the top crease. They should be higher than normal proportions.

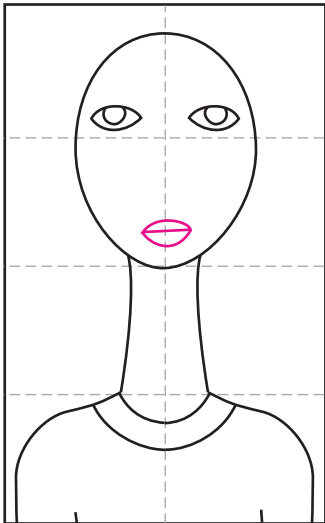

5. Draw the mouth extra low, LOWER than normal.

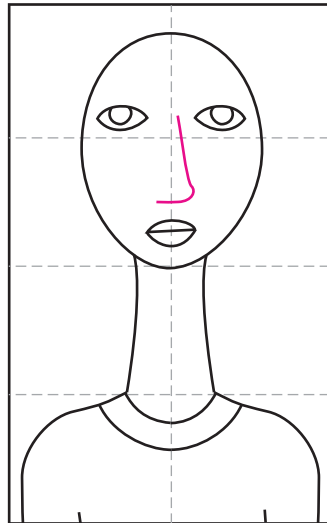

6. Draw a simple nose that fills in the space between the eyes and mouth.

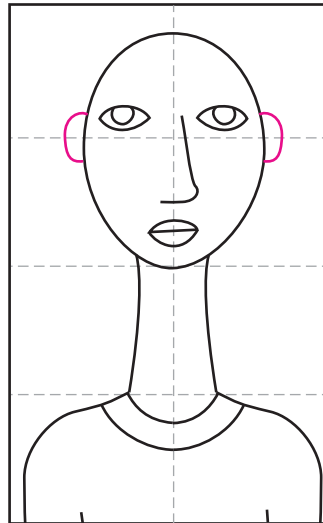

7. Draw two ears. They can be normal placement and size.

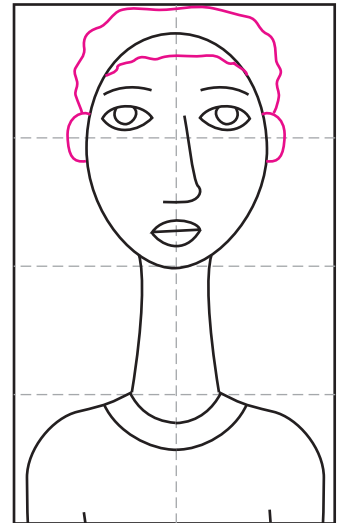

8. Add your own hair line. It's best to add it above the oval so it looks more dimensional.



9. Trace the art with a black pastel.



10. Trace the art again with the same pastel to make the lines really thick.

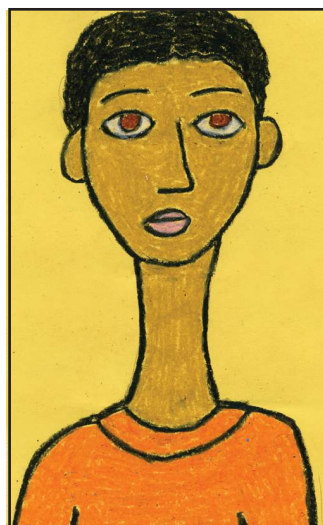

11. Color your self portrait with colors, making sure to press hard to make solid colors.



TIP? Keep the drawing VERY simple. Focus more on careful coloring and layering.

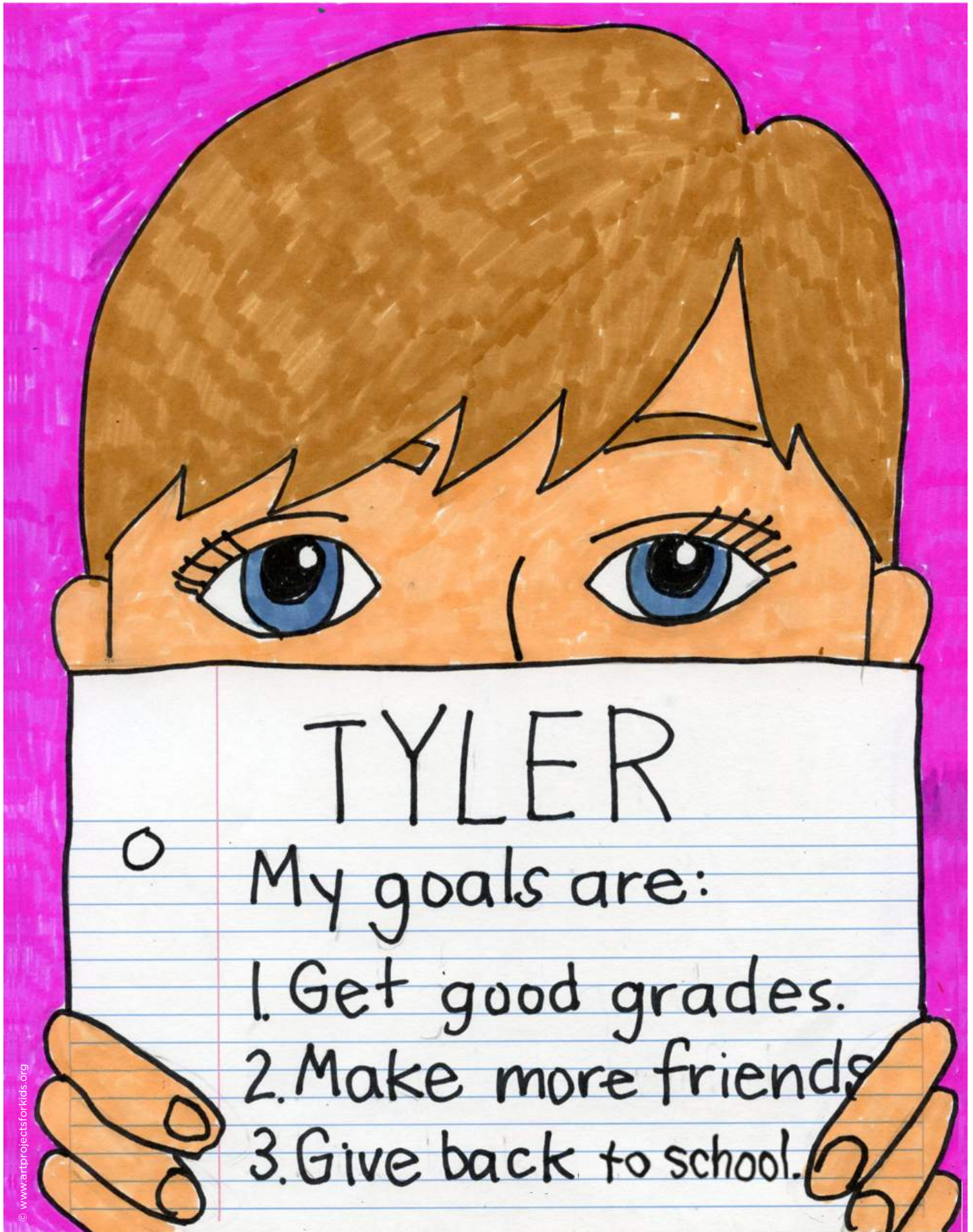

TYLER

o

My goals are:

1. Get good grades.

2. Make more friends.

3. Give back to school.

# My Goals Self Portrait

Students draw just the top of their head peeking out over a printed sheet of writing paper, which is used to write their name and then list some goals for the school year.

## COMMON CORE WRITING STANDARD

CCSS.ELA-LITERACY.W.3.1.A Introduce the topic or text they are writing about, state an opinion, and create an organizational structure that lists reasons.

## DIRECTIONS

PREP: Download and print template page for each student.

- Students follow the tutorial to draw themselves peeking out from behind the paper.
- Students write their name and then list their goals on the writing paper.
- The writing and art is traced with a black marker.
- The drawing is colored in with markers or crayons.

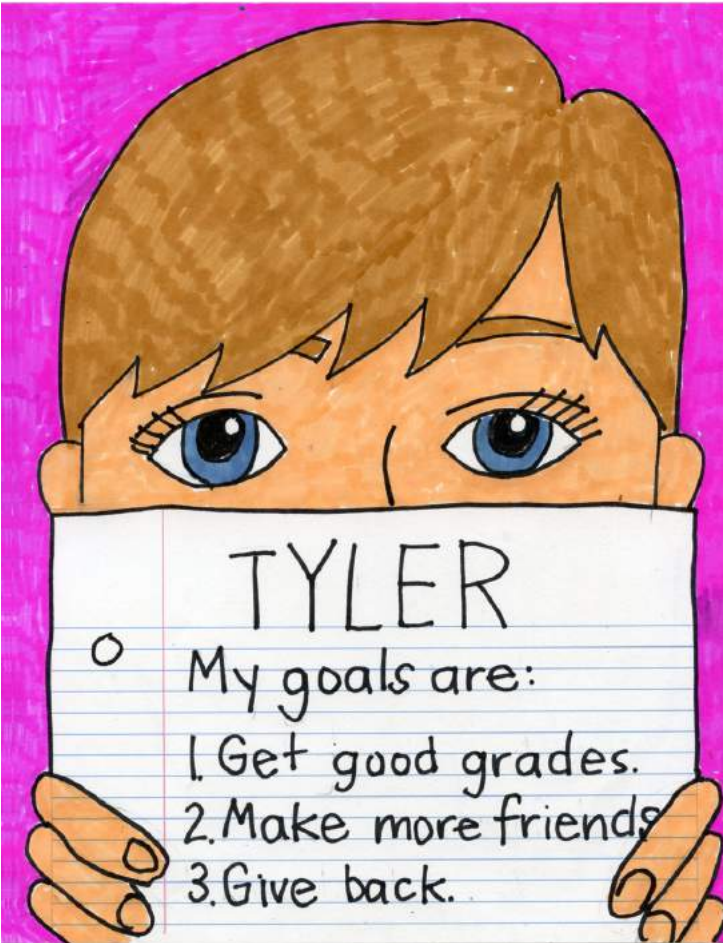

© www.artprojectsforkids.org

## MATERIALS

- White drawing paper
- Black marker
- Crayons or markers, preferably the media that offers the most skin color options

# My Goals SELF PORTRAIT TUTORIAL

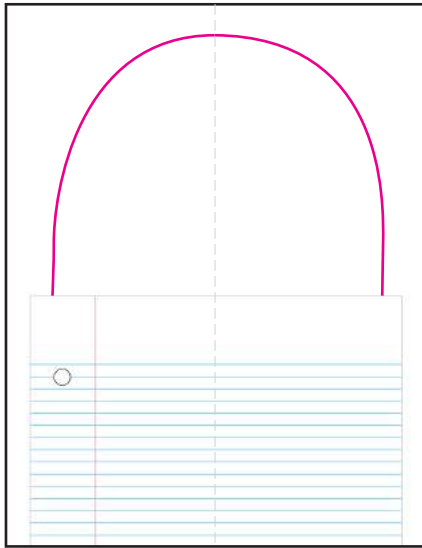

1. Fold paper in half to make guide.

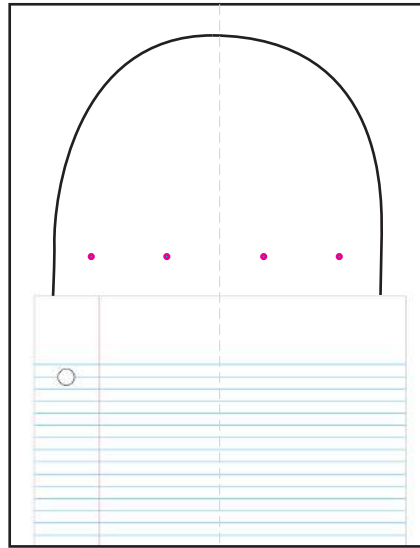

2. Plan eyes first with four dots.

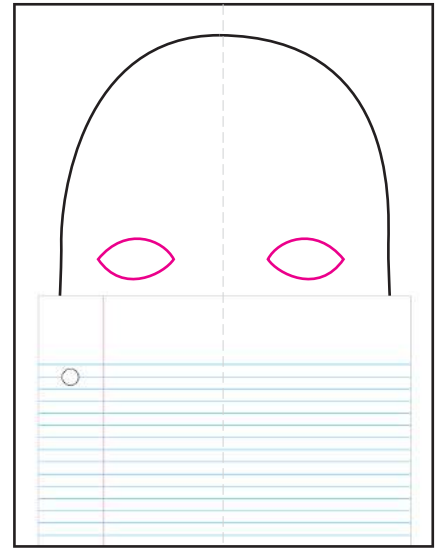

3. Draw the top and bottom of eyes.

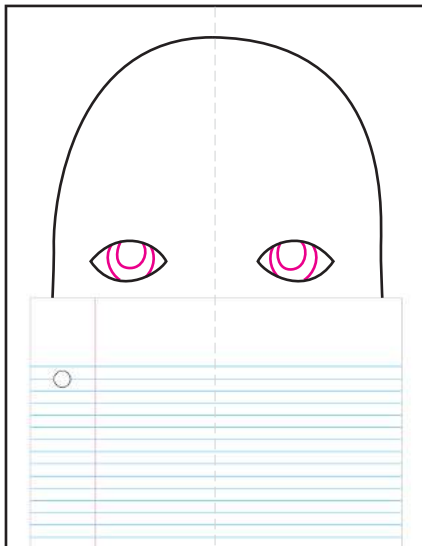

4. Draw the inside eye circles.

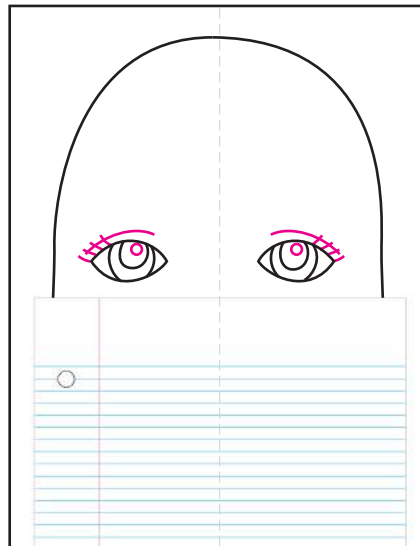

5. Finish eye details.

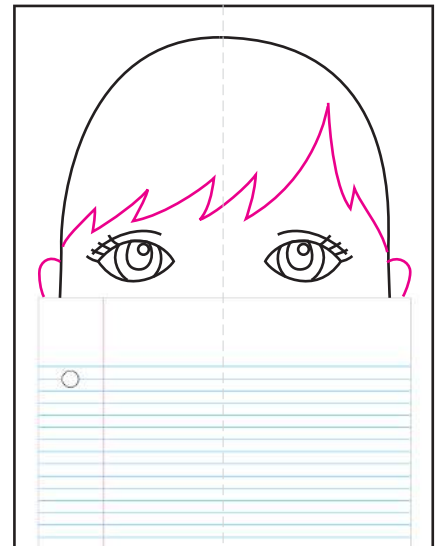

6. Draw ears. Add your own hairline.

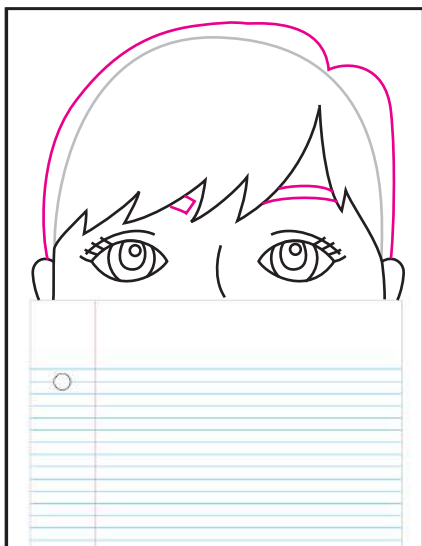

7. Add eyebrows and top hairline.

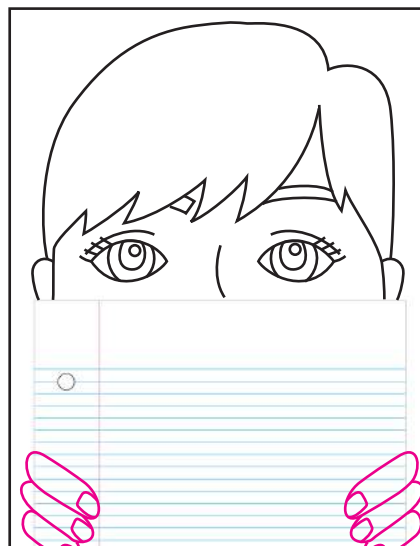

8. Draw fingers right over the paper.

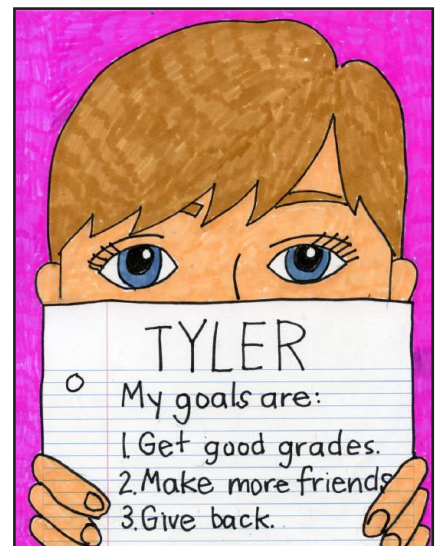

9. Add your goals and color carefully.



Chuck Close SELF PORTRAIT

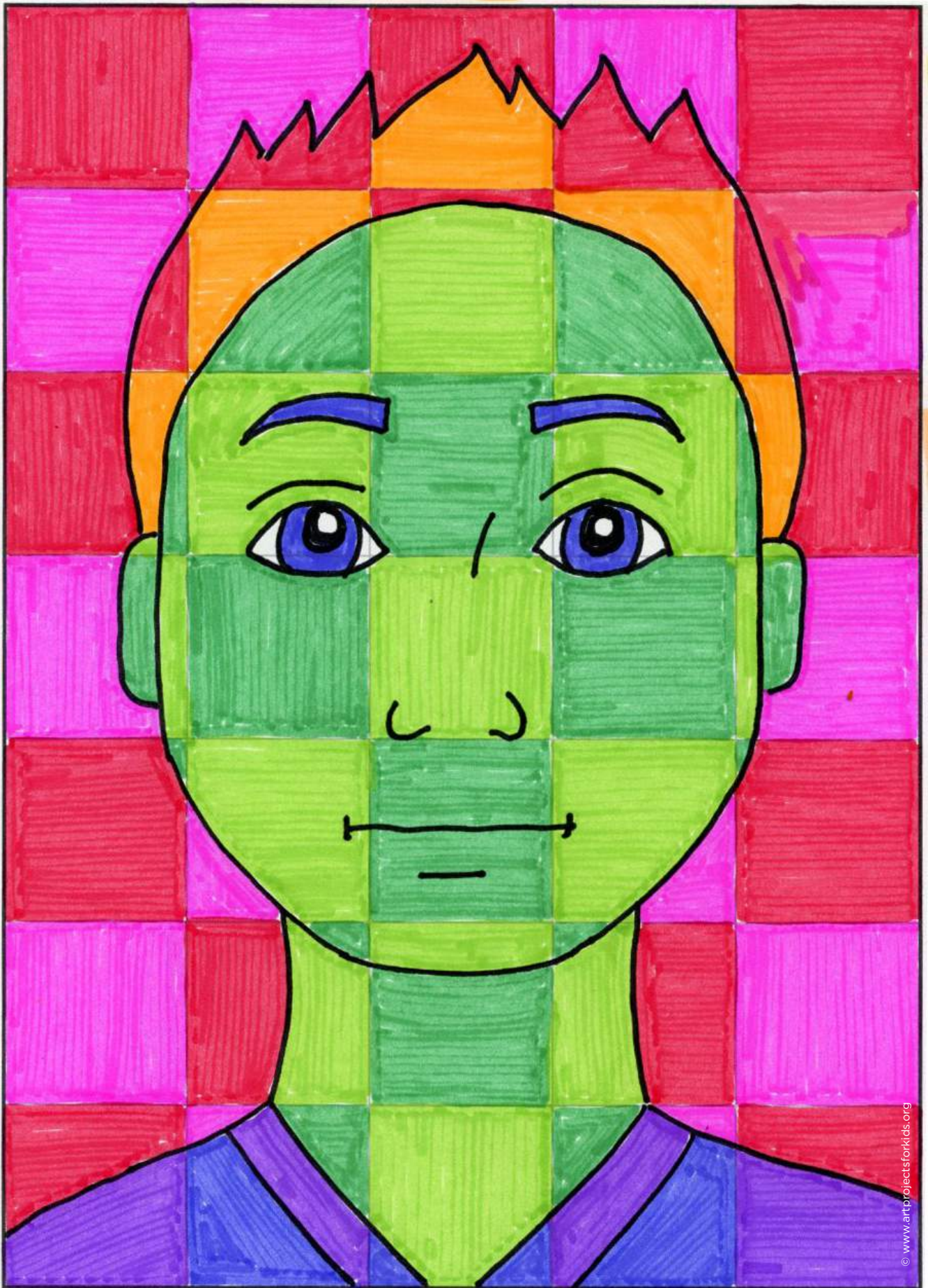

## Chuck Close Self Portrait

American artist Chuck Close is well-known for his photorealistic, large-scale portraits. Using a grid technique, Close is able to paint enlarged copies of portraits square by square.

This self portrait project simplifies the idea of coloring with a grid, and creates a fun checkerboard that can change colors for a fun and abstract look. I recommend coloring each section with similar colors so that the drawing doesn't become too broken up and hard to see.

### NATIONAL ARTS STANDARDS

VA:Cr2.1.5a Experiment and develop skills in multiple art-making techniques and approaches through practice.

### DIRECTIONS

PREP: Print grid template on page 42. Make a copy onto drawing paper for each student.

- Students follow the tutorial to draw a self portrait.
- The drawing is traced with a black marker.
- The face, clothes, hair and background are colored with a pair of similar colors. Start with the main face color, make a checkerboard. I used dark green.
- Complete the face checkerboard with a similar color. I used light green.
- Repeat process for clothes, hair, and background until the drawing is completely colored in. Keep in mind that contrasting groups of colors work best. For example, dark blue colors against dark purple colors may actually hide the shapes you are trying to show.

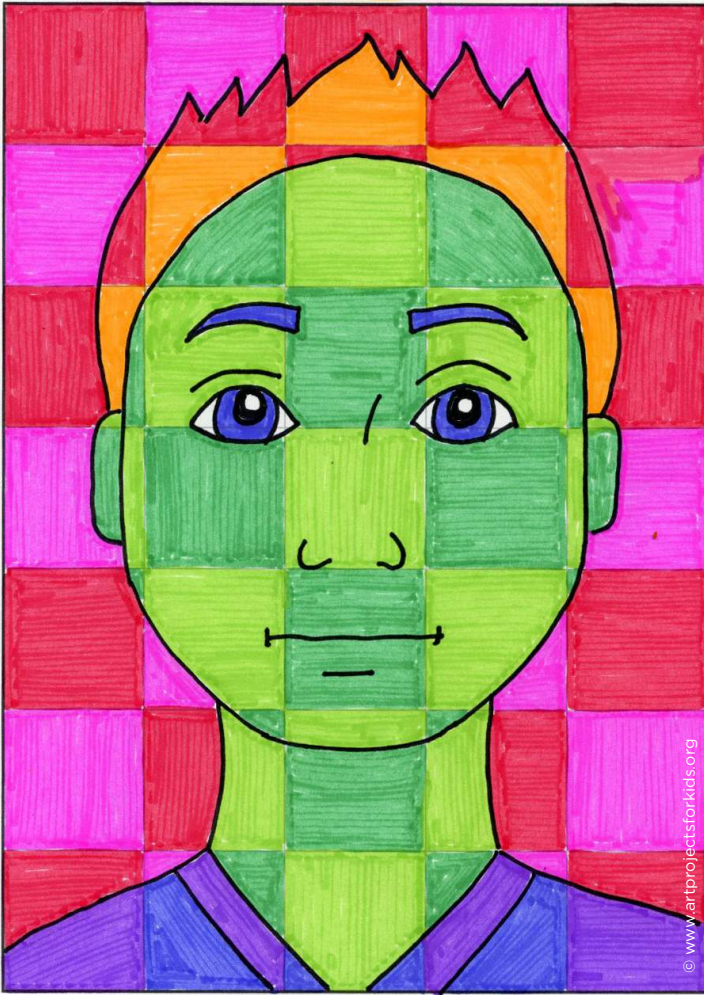

### MATERIALS

- Printed grid template
- White drawing or other heavy paper, 8.5" x 11"
- Thin black markers
- Markers (I prefer the Stabilo® Power Markers)



# Chuck Close SELF PORTRAIT TUTORIAL

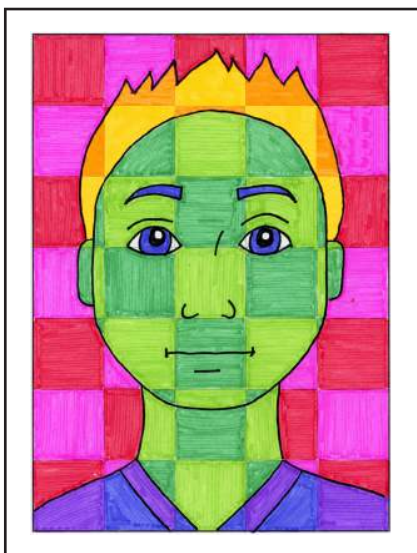

Supplies: Markers (I like Stabilo®)

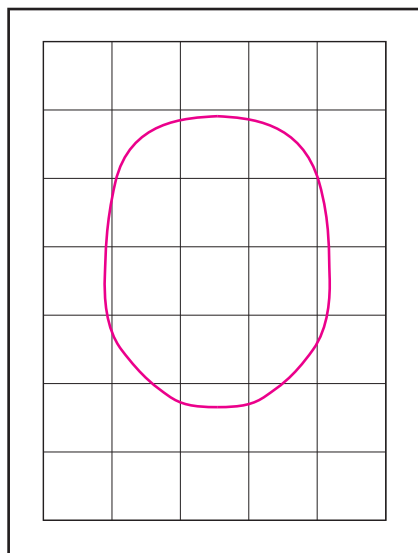

1. Draw an oval head.

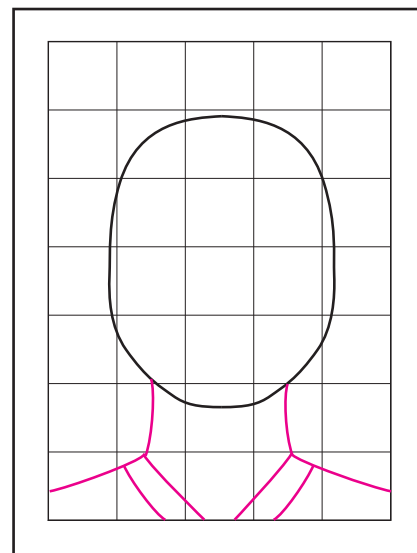

2. Draw neck, shoulders, shirt.

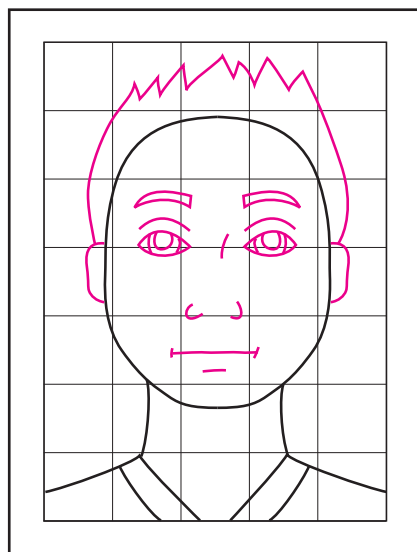

3. Add facial features, ears, hair.

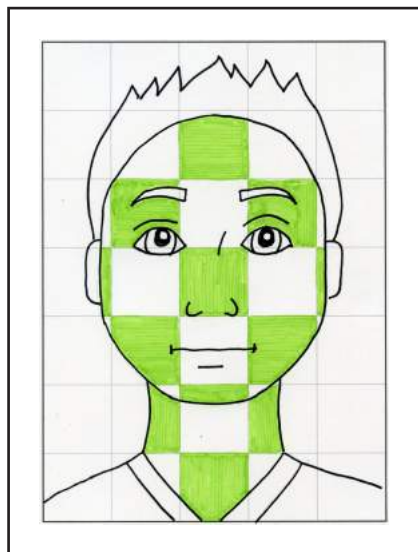

4. Trace drawing. Color in face.

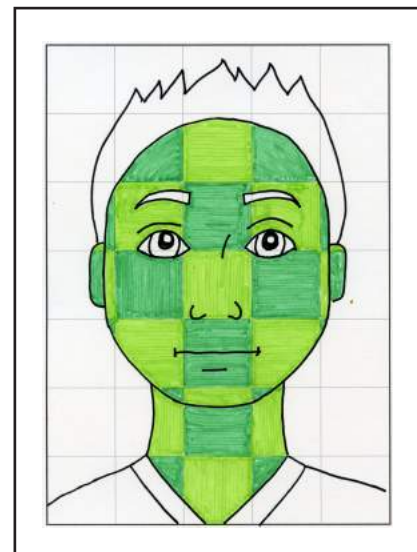

5. Finish face with similar color.

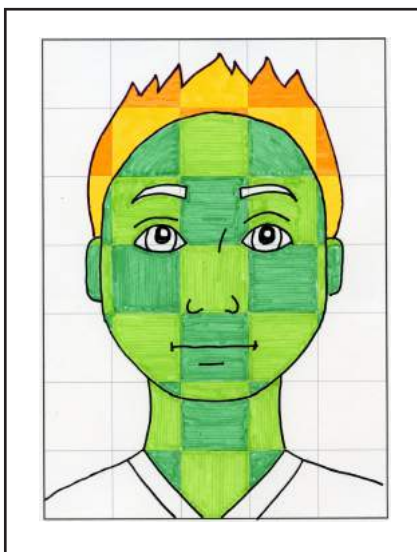

6. Color hair with two similar colors.

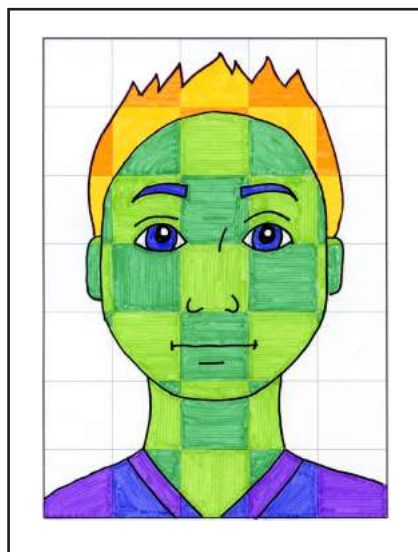

7. Color shirt with two similar colors.

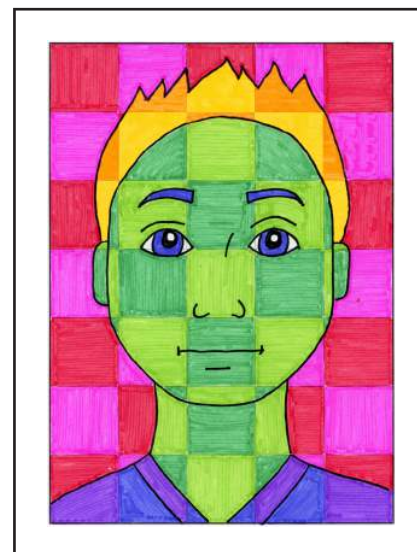

8. Color back with similar colors.



Half Portrait SELF PORTRAIT

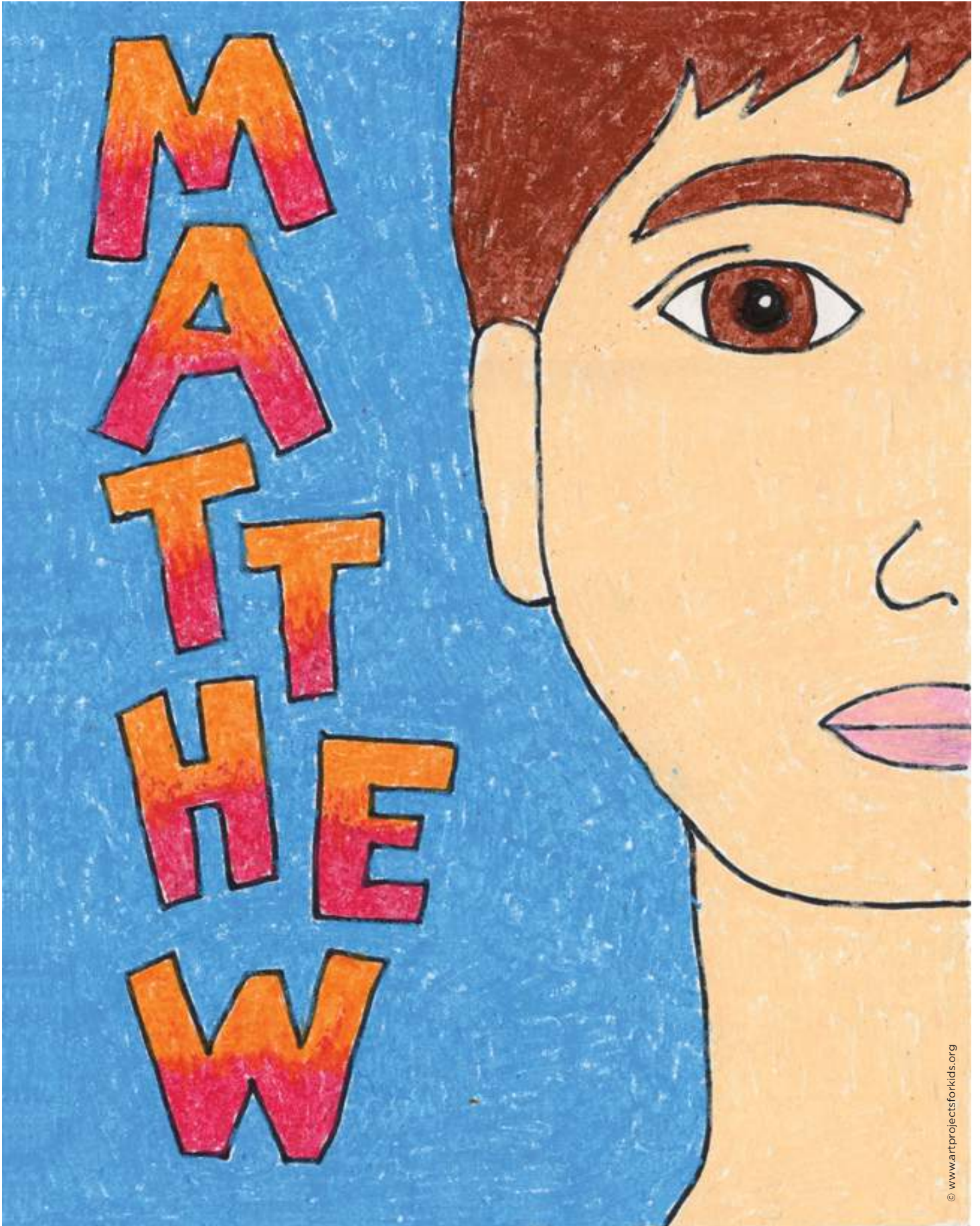

## Half Portrait

This project helps students draw a well-proportioned face without spending too much time trying to make it perfectly symmetrical. By drawing half the face, and making it go off the paper, there's plenty of room to draw nice big facial features. There's also plenty of space to add a name in some kind of stacked format.

### NATIONAL ARTS STANDARDS

VA:Cr1.2.2a Make art or design with various materials and tools to explore personal interests, questions, and curiosity.

### DIRECTIONS

PREP: Print the grid on page 26 for each student, or instruct them on how to fold a paper three times to create the same grid.

- Students follow the tutorial to draw the face.
- The student's name is added on the left. Creative stacking of letters may be necessary for longer names.
- The drawing is traced with a black marker.
- The drawing is colored in with crayons or oil pastels.

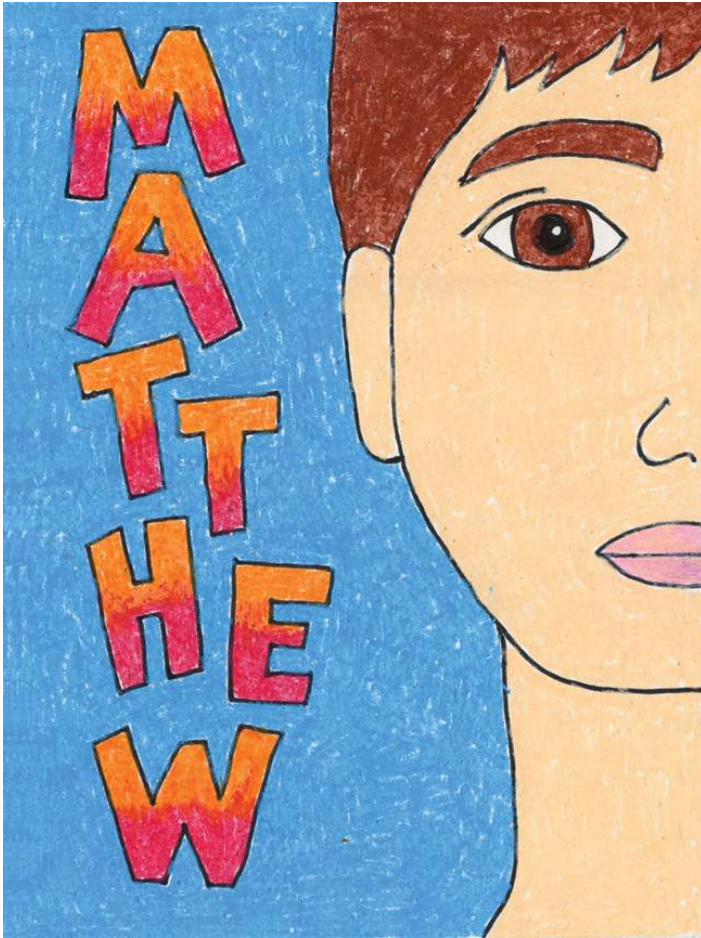

### MATERIALS

- White drawing paper
- Black marker
- Oil pastels or crayons

### MORE IDEAS FOR DRAWING HAIR

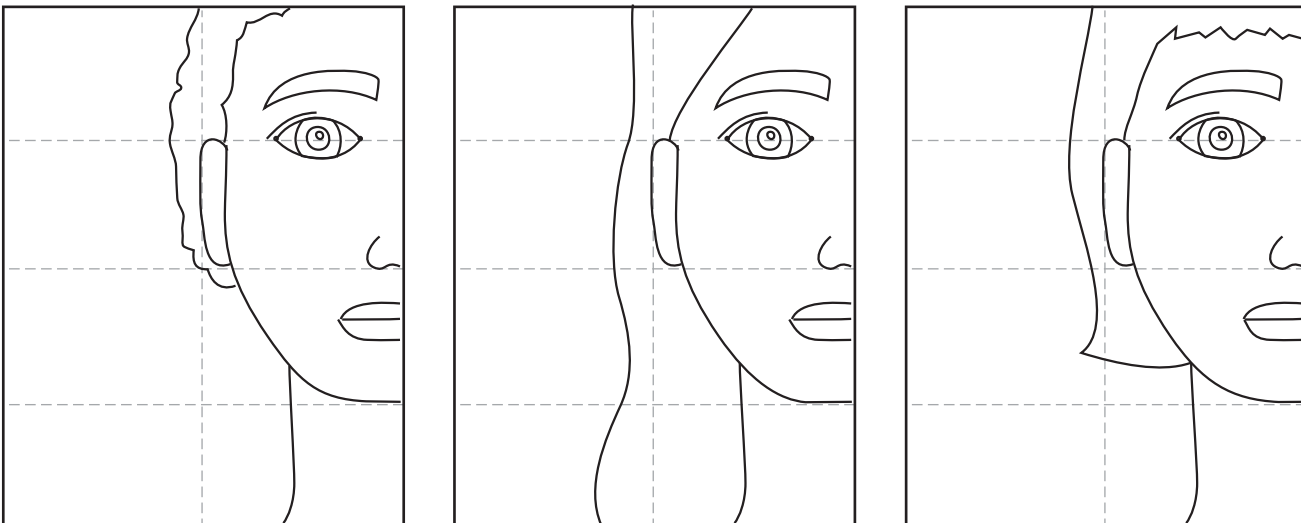

# Half Portrait ART PROJECT TUTORIAL

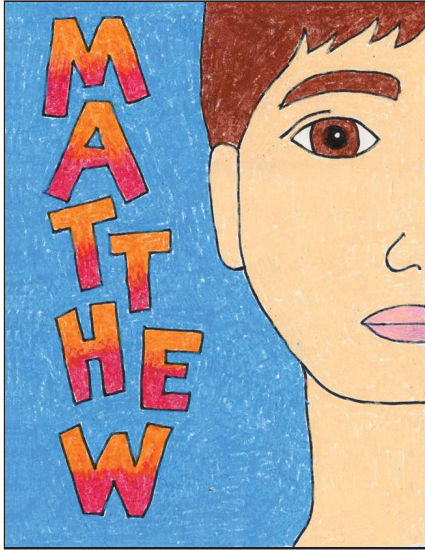

Supplies: Black marker, crayons

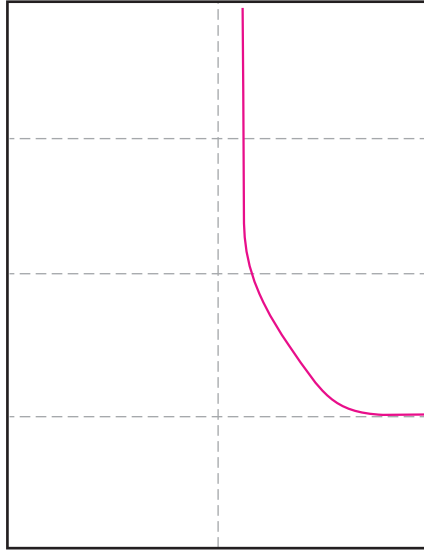

1. Fold paper to make guides. Start the head.

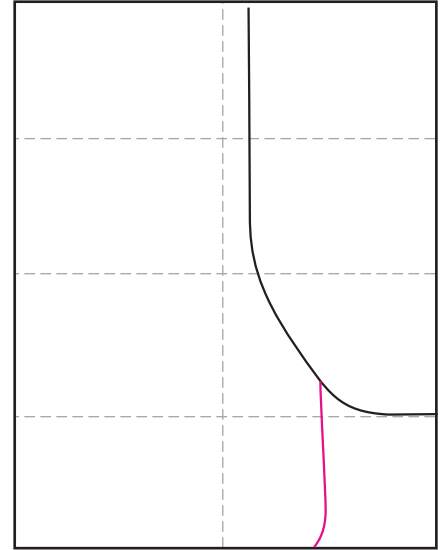

2. Draw neck line.

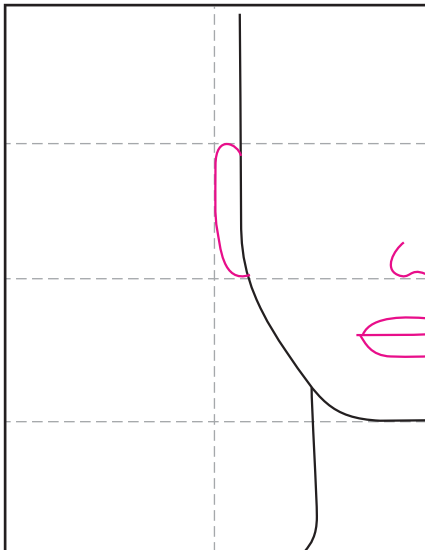

3. Add ear, nose and mouth.

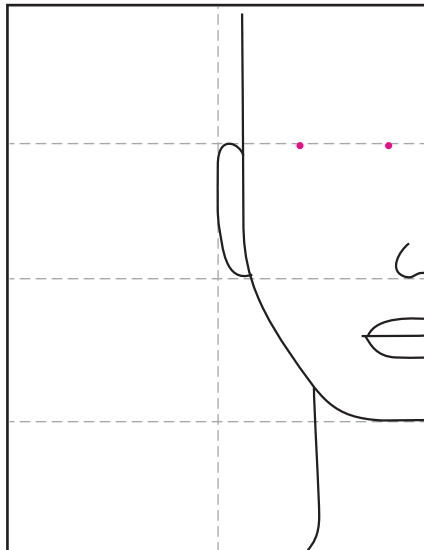

4. Plan eye with two dots.

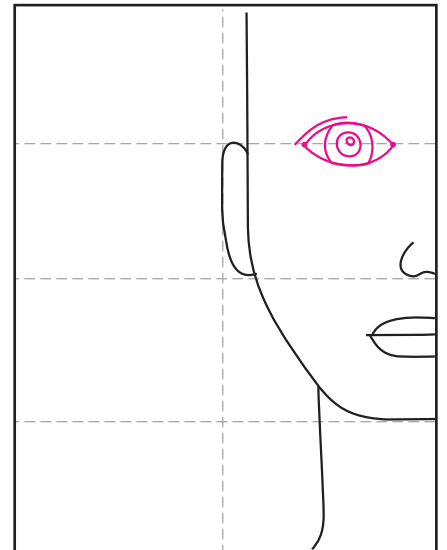

5. Fill in the eye.

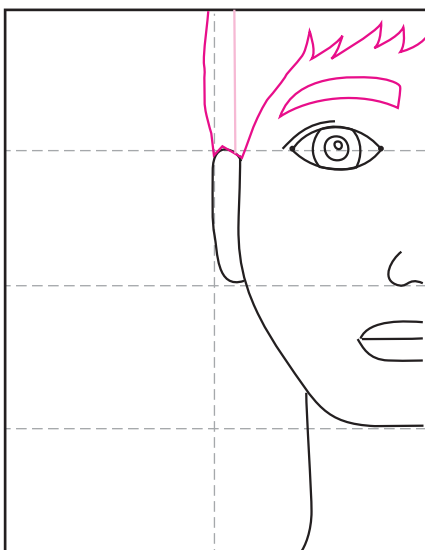

6. Add eyebrow and hair. Erase line.

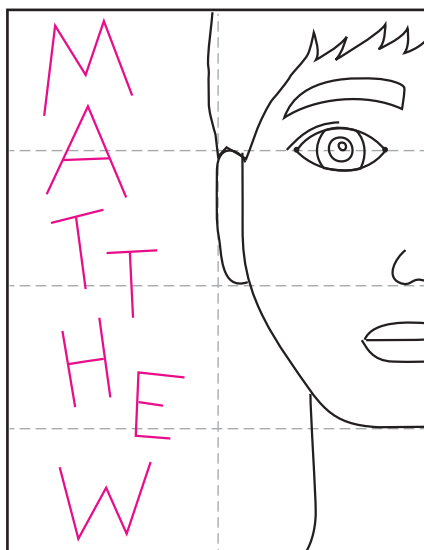

7. Draw name in stick letters.

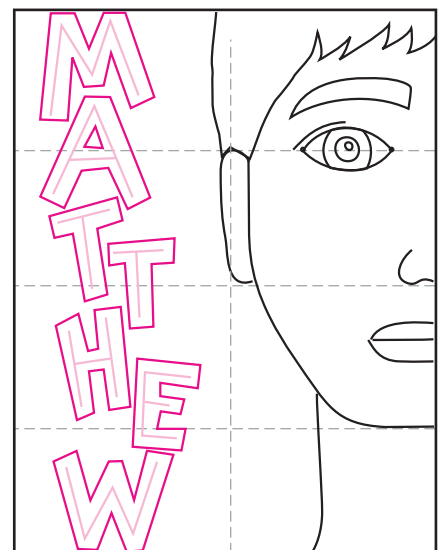

8. Outline letters. Trace and color.

# Minecraft SELF PORTRAIT

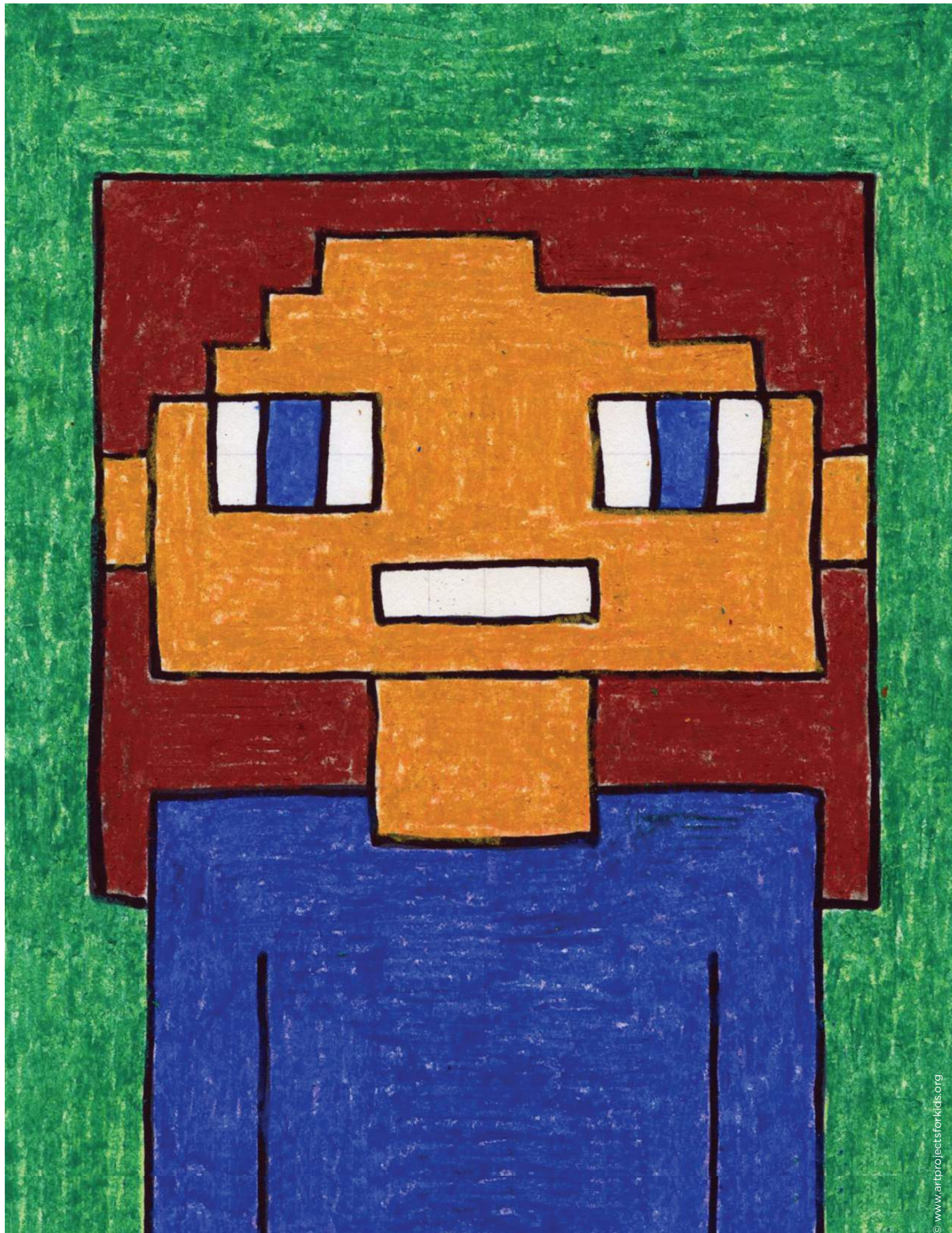

Minecraft SELF PORTRAIT



# Minecraft Self Portrait

If you want to capture your students attention, mix a little pop culture into their art lesson. This one works with the very familiar world of Minecraft, and challenges them to draw without using any diagonal lines. It's also a great study of symmetry, as the graph paper lets them count out boxes to get very precise.

## COMMON CORE MATH STANDARD

CCSS.MATH.CONTENT.4.G.A.3 Recognize a line of symmetry for a two-dimensional figure as a line across the figure such that the figure can be folded along the line into matching parts.

## DIRECTIONS

PREP: Print a Minecraft grid paper on page 50 for each student.

- Students find the center vertical line (count boxes) and lightly trace over it to help make the symmetrical face. This is just a guide, and will be erased when finished.
- The eyes are drawn on either side of the center line. They should be at least 3 boxes wide so there can be white on either side of the color.
- The mouth is drawn below, still centered on the middle line.
- The side and bottom of the head are drawn around the eyes and mouth, leaving the top head open.
- The hairline is drawn, using either a straight line or stair steps to make an angle.
- The neck and body are drawn below the head, still centered on the middle line. Add details that stay on the grid lines.
- The outer hair line is drawn. Neat tracing and coloring are needed to keep the Minecraft look. There's no such thing as a scribbly pixel.

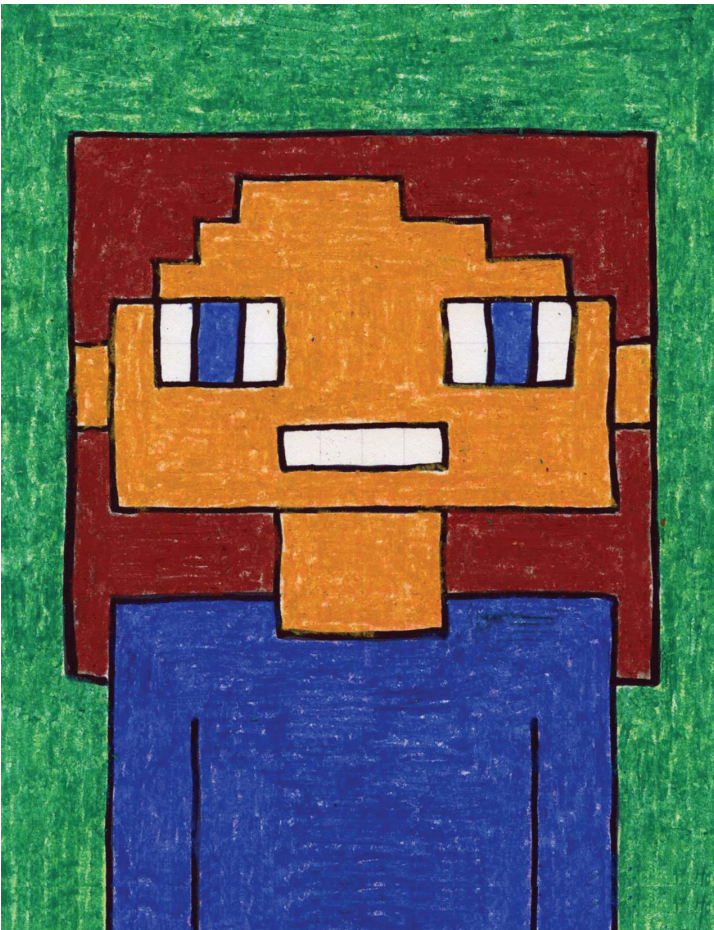

© www.artprojectsforkids.org

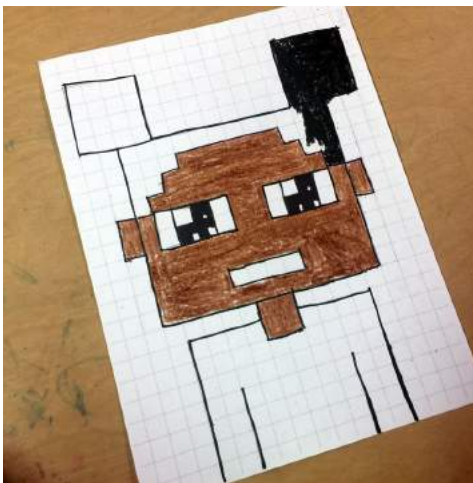

## MATERIALS

- White drawing paper, 8.5"x 11"
- Black marker
- Crayons or pencil crayons



# Minecraft SELF PORTRAIT TUTORIAL

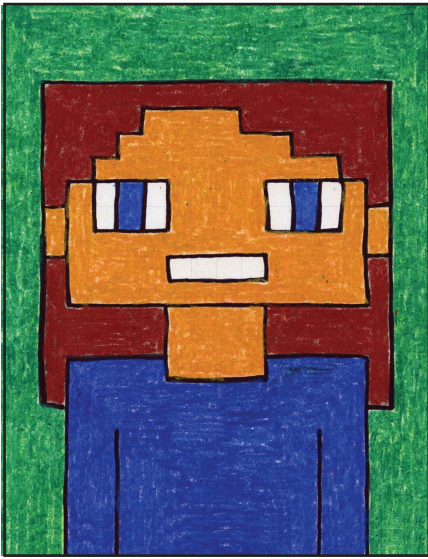

Supplies: Grid paper, black marker, crayons

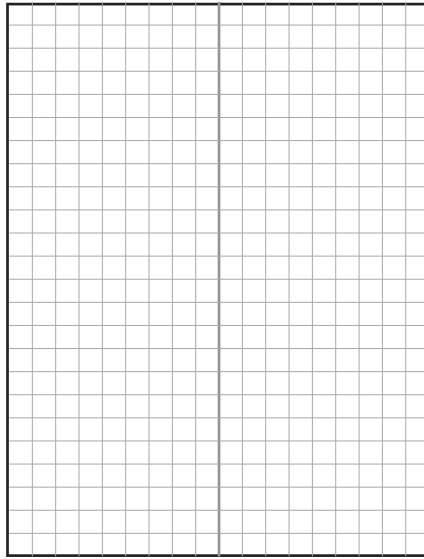

1. Count boxes to find the center line. Use math or estimate and check.

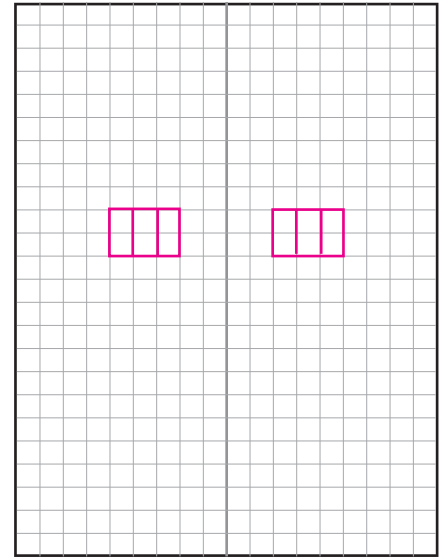

2. Draw two symmetrical eyes.

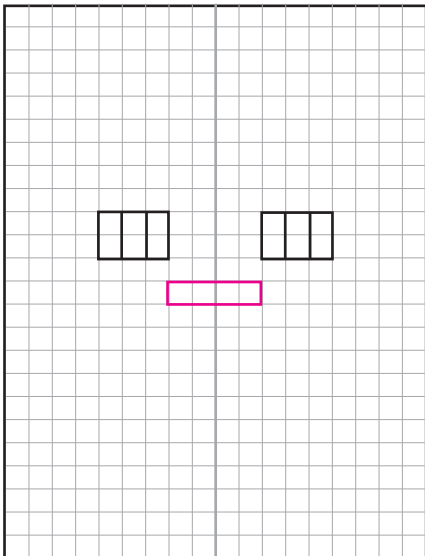

3. Draw a symmetrical mouth.

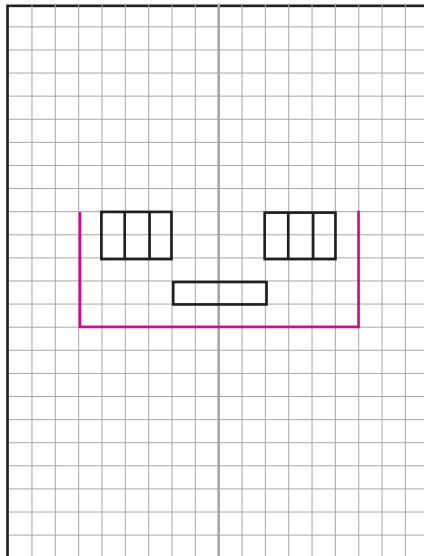

4. Start the bottom of the head.

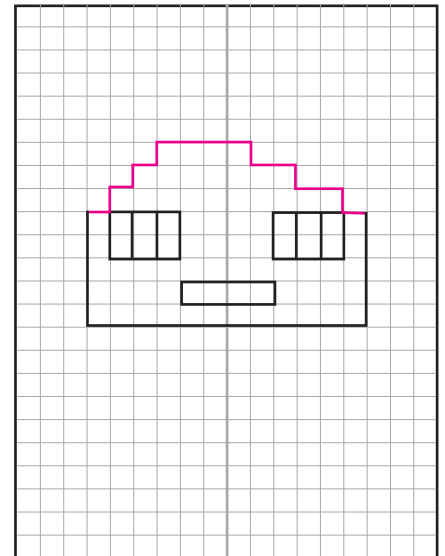

5. Draw the hair line.

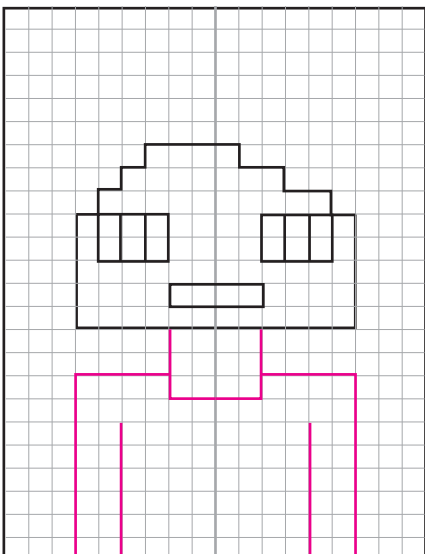

6. Draw a neck and body.

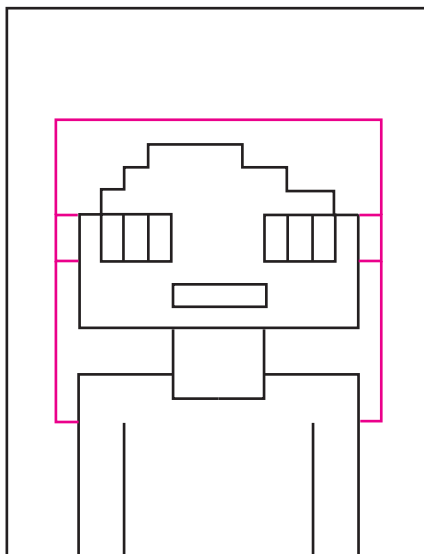

7. Finish the outer hair line.

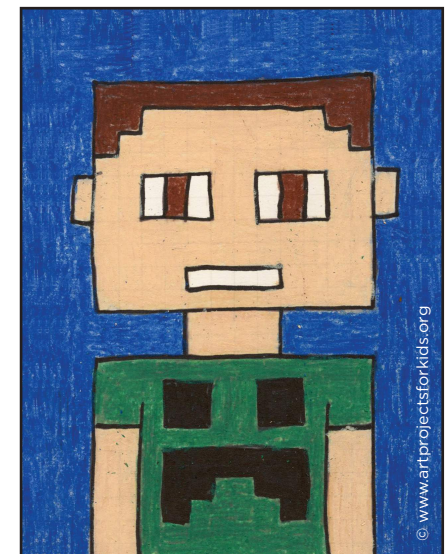

Example of a Minecraft boy selfie.

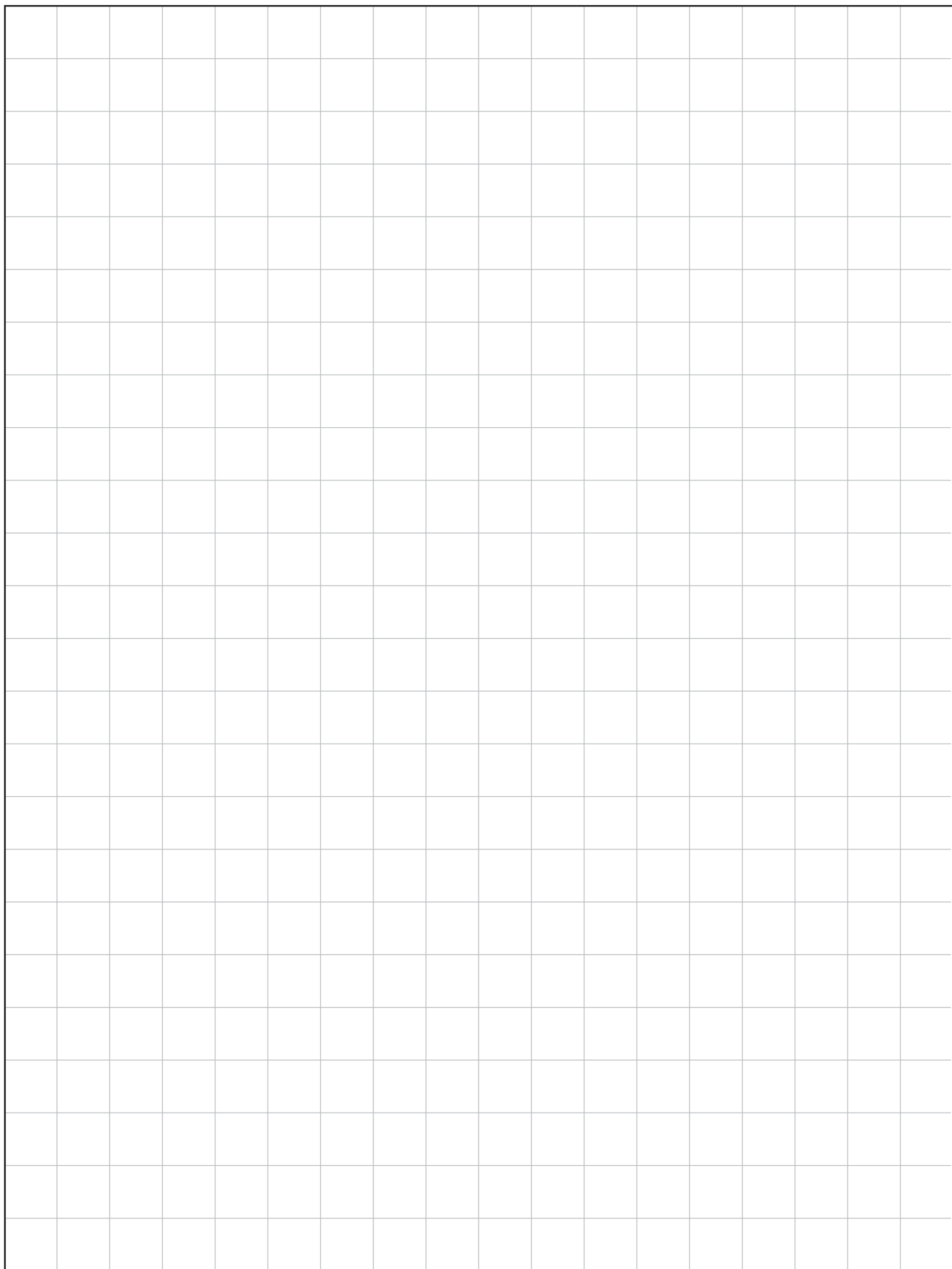

Wanted Poster SELF PORTRAIT

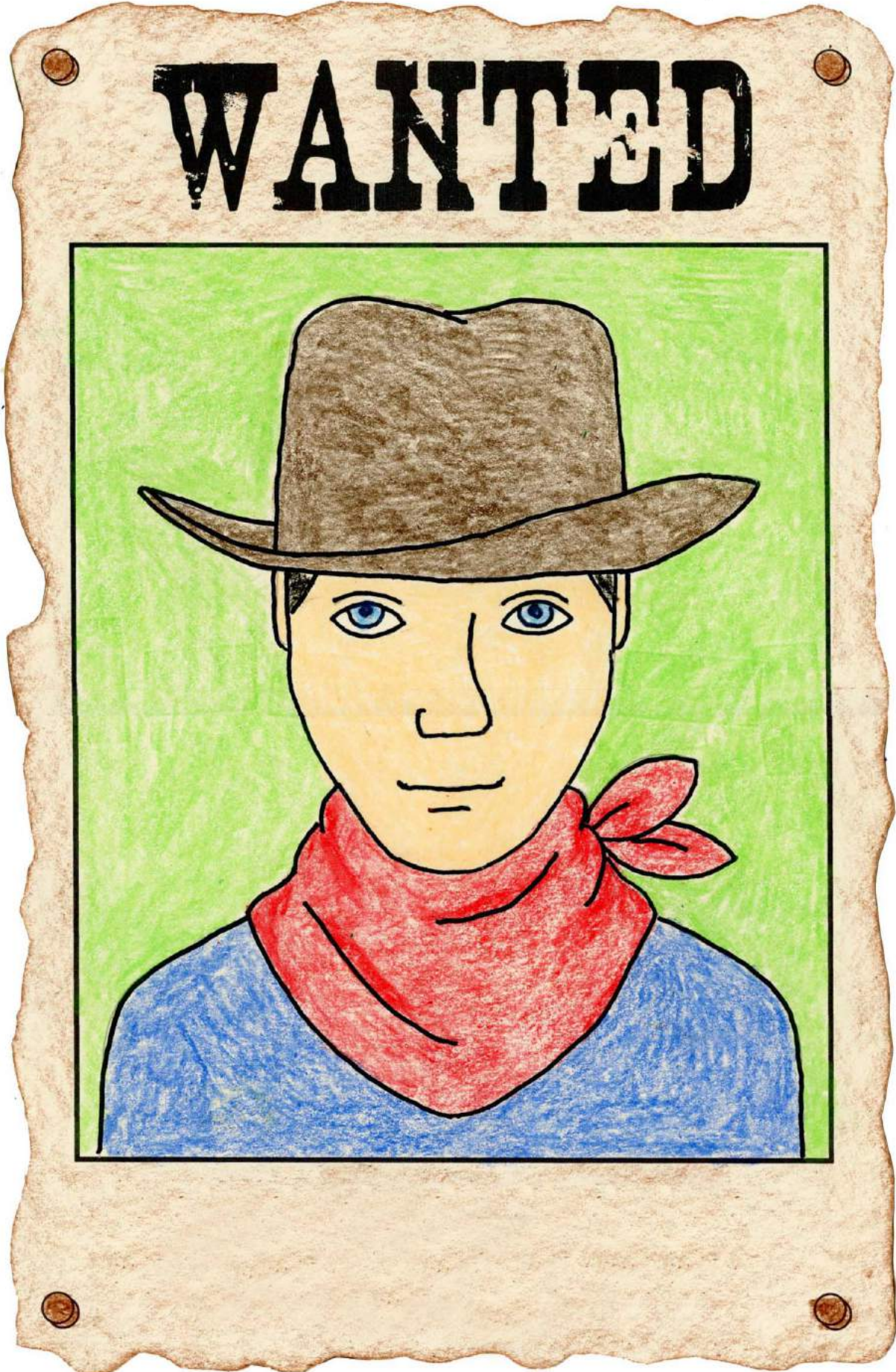

Wanted Poster SELF PORTRAIT



## Wanted Poster

Studying the Gold Rush era? My tutorial shows students how to draw themselves in a cowboy hat, with a handkerchief tied around their neck. For extra fun, I've included a template to turn it into a large poster. There's lots of space to add their name at the bottom.

### NATIONAL ARTS STANDARDS

VA:Cn11.1.4a Through observation, infer information about time, place, and culture in which a work of art was created.

### MATERIALS

- Cream card stock paper, 67 lb. recommended
- Paper cutter
- Masking tape
- Black Sharpie marker
- Crayons
- Scissors

### DIRECTIONS

**PREP:** Teachers print a top and bottom template for each student. A paper cutter is best to trim the side that will get taped.

- Students tape their two sheets together on the back. No overlapping is needed.
- Students follow the tutorial to draw themselves inside the rectangle.
- The drawing is traced with a black marker.
- The portraits are colored neatly with crayons.
- Students cut out their posters along the curvy edge to make it look torn.
- The side of a paperless crayon is rubbed along the outer edge to create a dark, burned look.



# Wanted Poster SELF PORTRAIT TUTORIAL



Supplies: Black marker, crayons

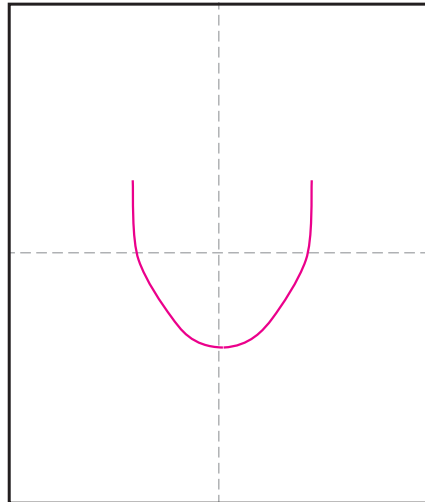

1. Make guide lines. Draw a U.

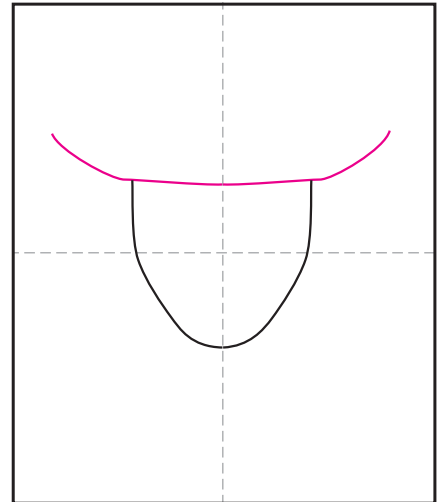

2. Start the cowboy hat.

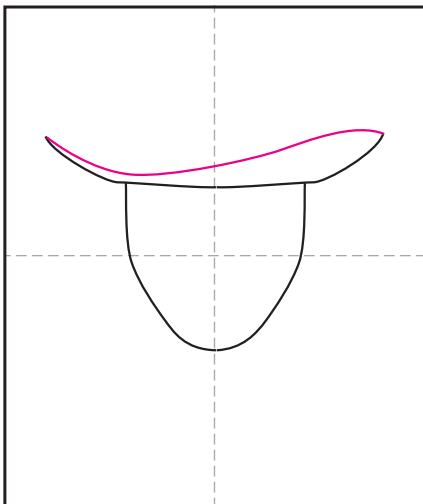

3. Add the curved brim.

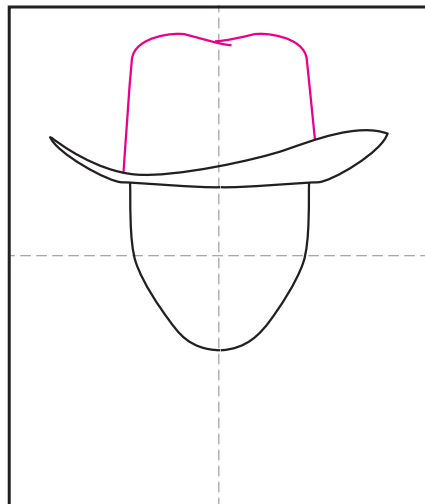

4. Finish the hat top.

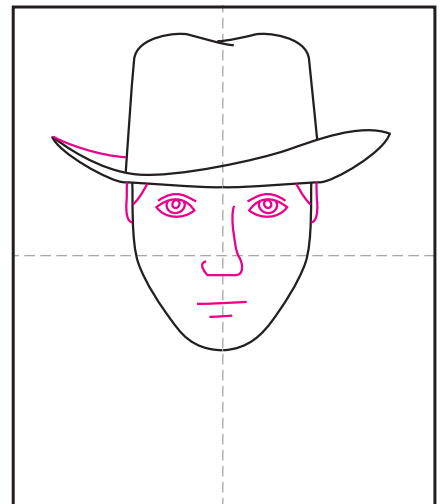

5. Add brim edge. Draw the face.

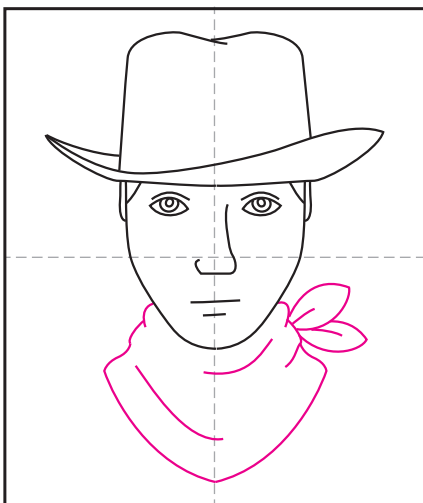

6. Add a handkerchief and ties.

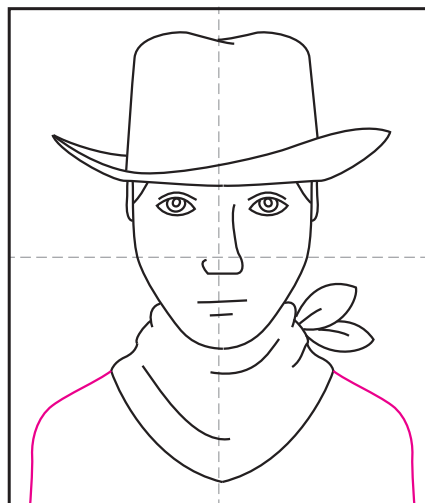

7. Draw the shoulders.

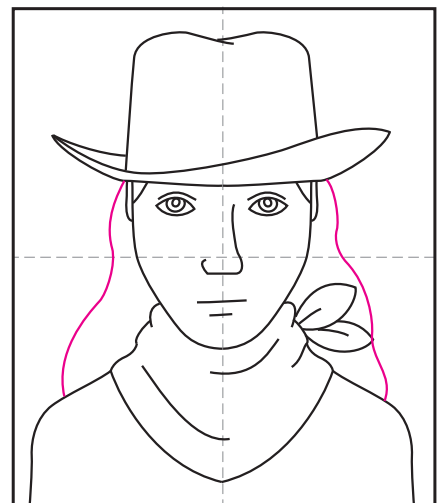

8. Add hair as needed. Cut edge of paper and rub with side of crayon for an aged look.

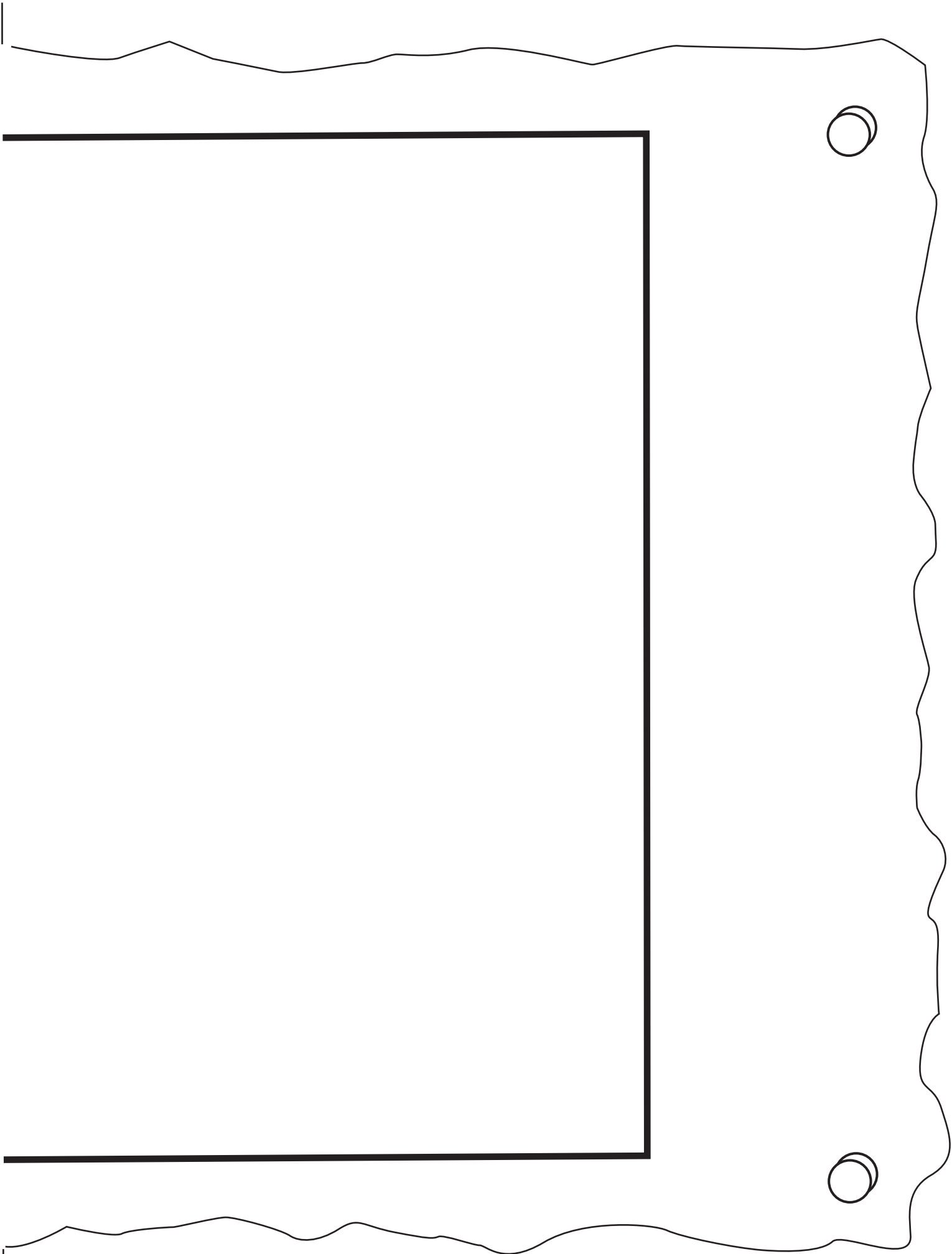

Trim with paper cutter

**WANTED**





Lichtenstein SELF PORTRAIT



# Lichtenstein Self Portrait

Roy Lichtenstein was a prominent American pop artist who favored old fashioned comic strips as a subject matter.

Roy was known to use Ben Day dots, a system invented to increase the range of colours available to newspaper printing. While a dot printing project is not practical for most young artists, using a pre-printed background is. It allows students to get the same look with just some very careful (and patient!) coloring.

## NATIONAL ARTS STANDARDS

VA:Cr1.1.5a Combine ideas to generate an innovative idea for art-making.

## DIRECTIONS

PREP: Print a Lichtenstein circle paper found on page 61 for each student. Drawing paper or heavier stock paper is recommended.

- Students use the tutorial to lightly draw their head and shoulders in pencil on the circle paper.
- The drawing is traced with a black marker. For an added illustrated look, some of the lines may be thickened in places where there might be small shadows.
- The eyes and eyebrows are filled in with whatever color is desired.
- The face circles are colored with a skin color.
- The circles in the rest of the drawing are filled in.
- If additional color is desired, the background is lightly shaded with the matching circle color. Keep the pencils sharp and use the sides to get a nice two tone look for each section.

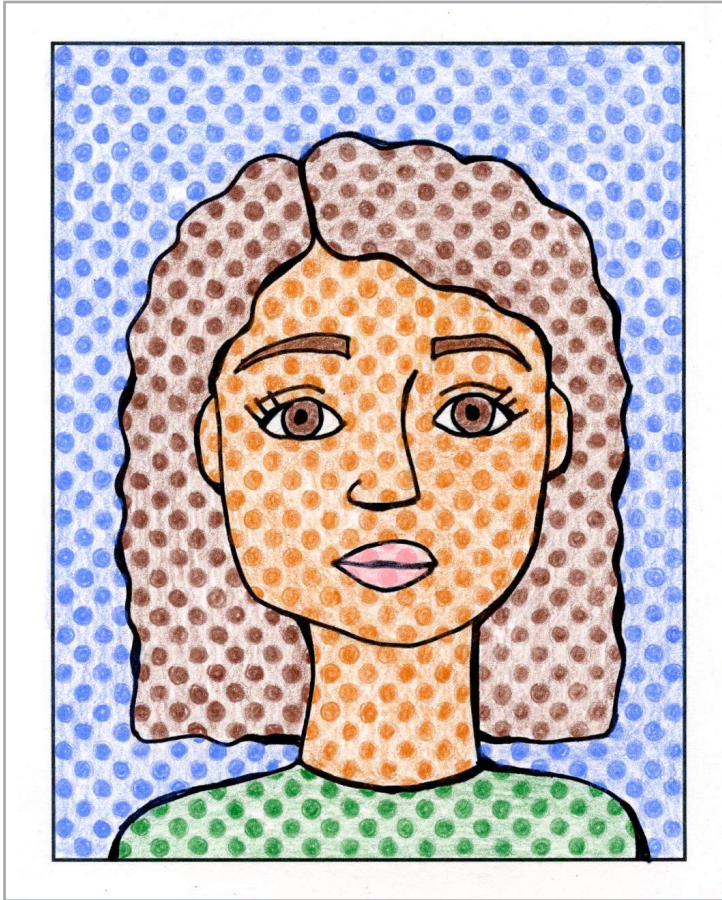

© www.artprojectsforkids.org

## MATERIALS

- White drawing paper or heavier stock paper
- Black marker
- Pencil crayons
- Pencil sharpener

# Lichtenstein SELF PORTRAIT TUTORIAL



Supplies: Marker, pencil crayons

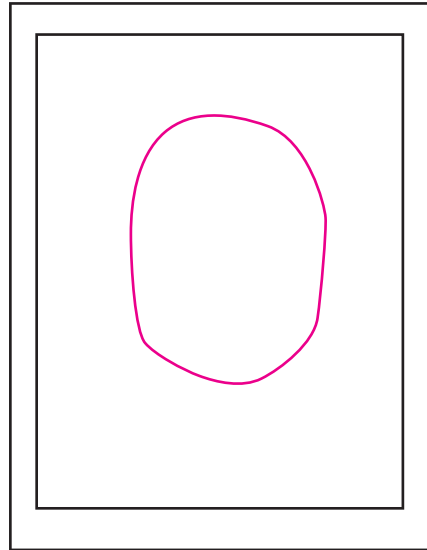

1. Draw an oval.

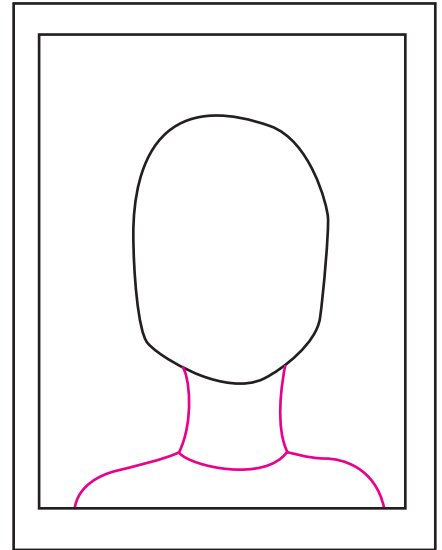

2. Draw neck and shoulders.

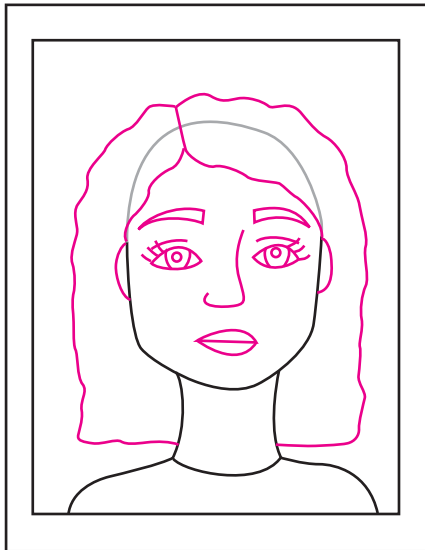

3. Add face and hair.

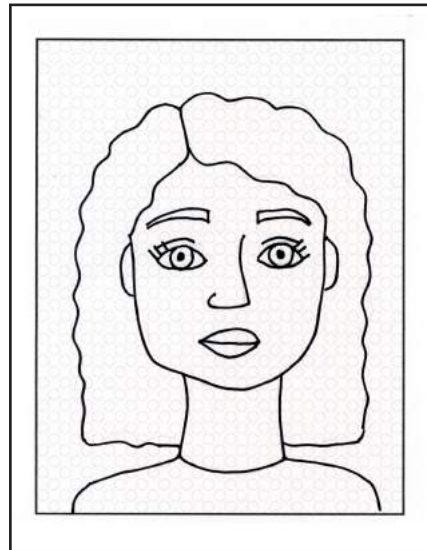

4. Trace the drawing with a marker.

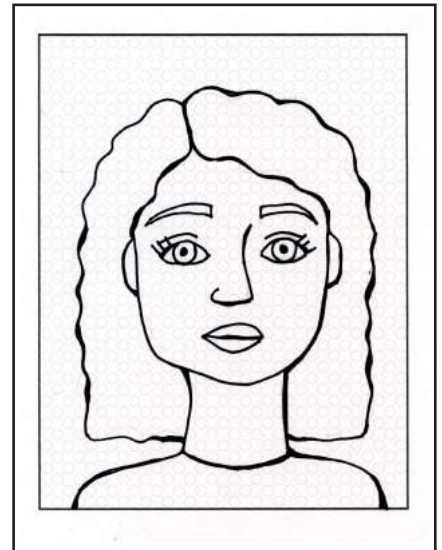

5. Make some lines thicker.

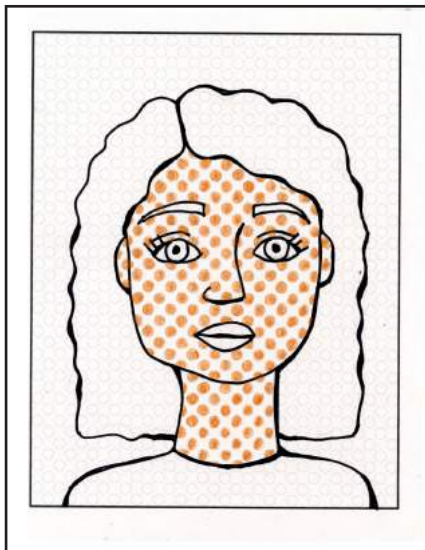

6. Color face dots with skin color.

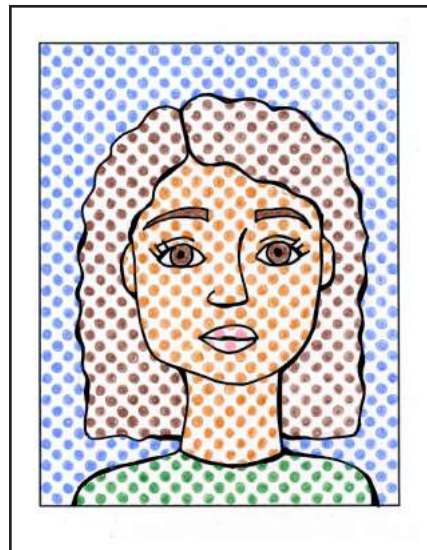

7. Color eyes and brows solid.  
Color clothes and background dots.

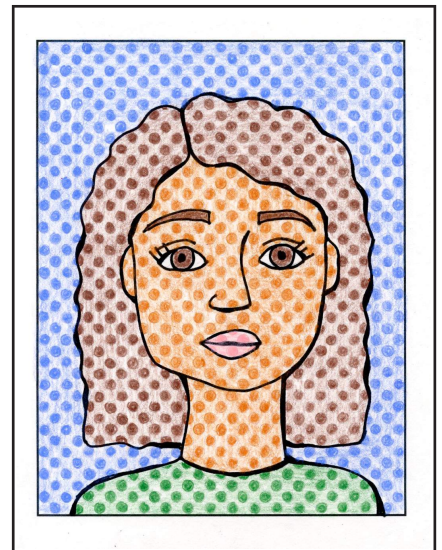

8. For added color, shade areas with the side of your pencil.

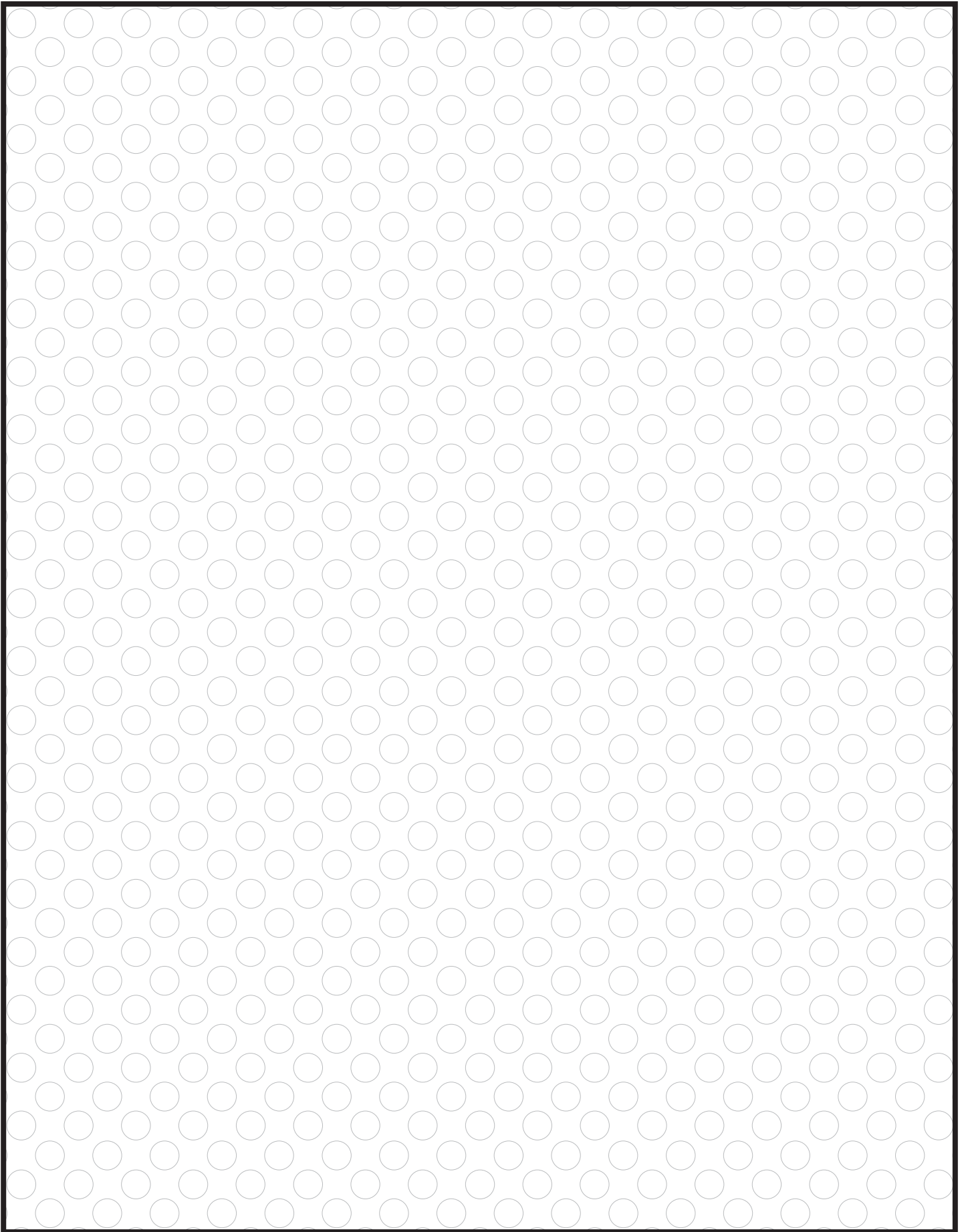



Extra wide binder art — TOP

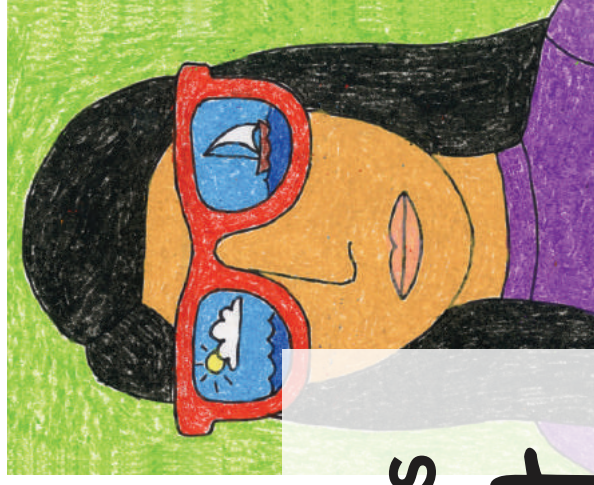
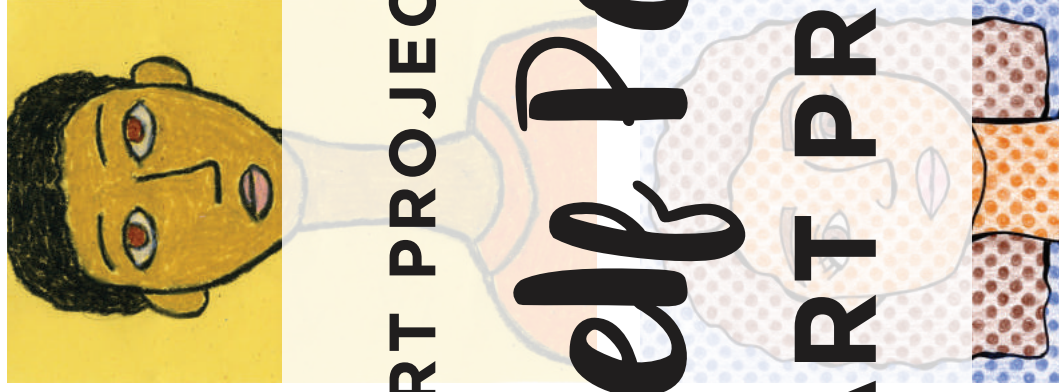
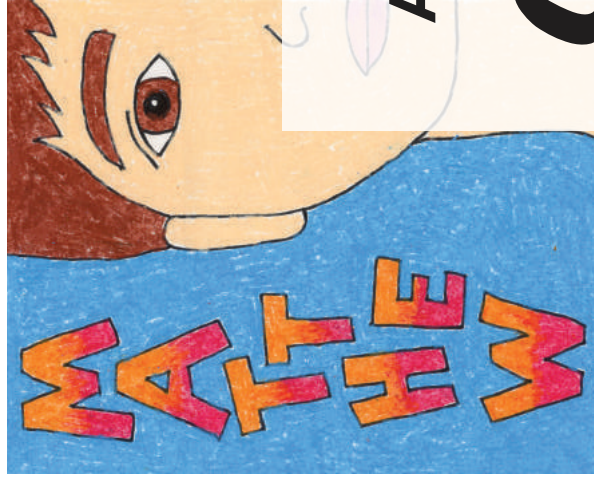

ART PROJECTS FOR KIDS

# Self Portrait

ART PROJECTS

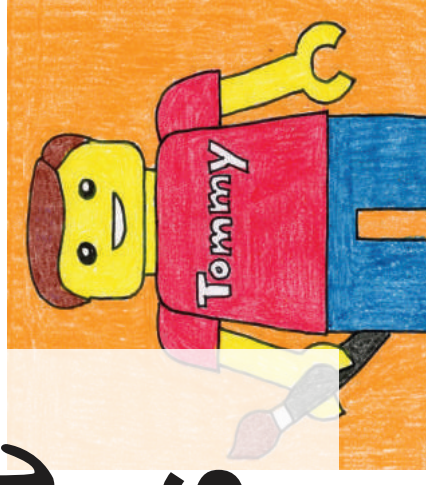
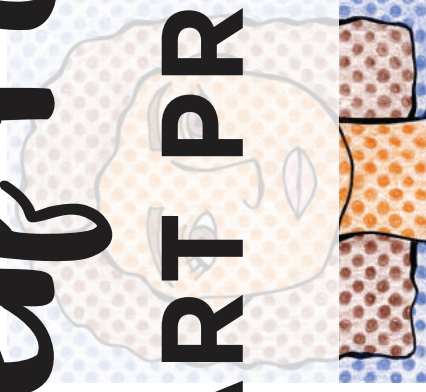
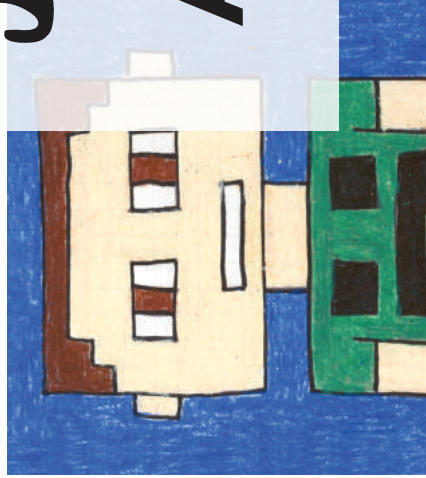

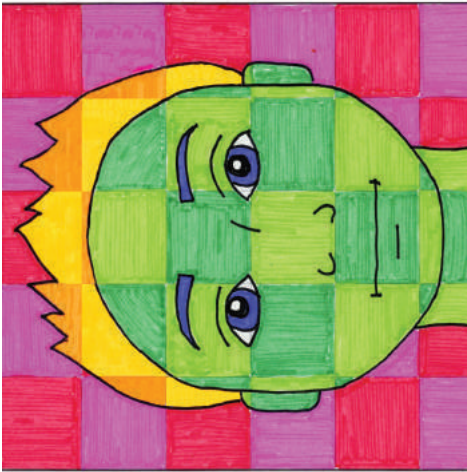
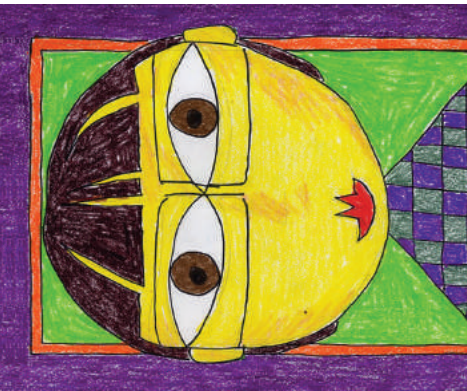
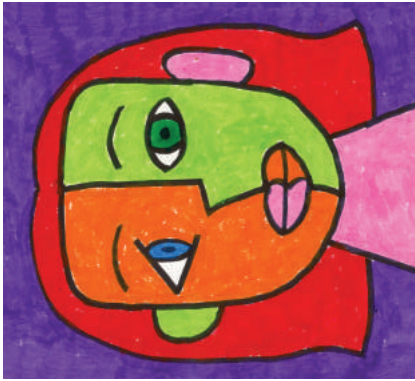
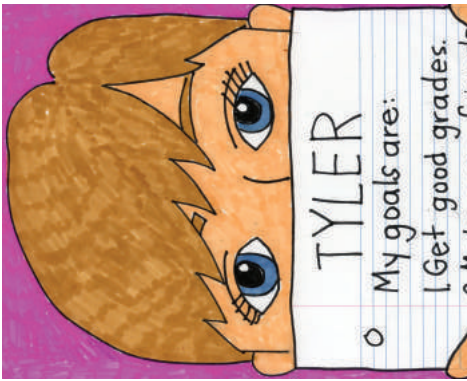

Extra wide binder art — BOTTOM