



# VALENTINE



# DRAWING

## Art Projects for Kids



# Valentine Drawings

## Table of Contents



Bird and Envelope  
pg 5-7



Candy Hearts  
pg 8-10



Cat and Balloon  
pg 11-13

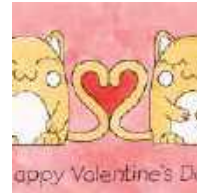

Cats and a Heart  
pg 14-16



Cupid  
pg 17-19



Dog in a Cup  
pg 20-22

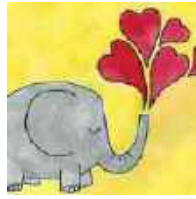

Elephant  
pg 23-25



Happy Valentine's Day  
pg 26-28



Heart & Ribbon  
pg 29-31



Heart Hand  
pg 32-34



Heart with Wings  
pg 35-37



Hedgehog  
pg 38-40



I Heart You Burst  
pg 41-43



I Love You Bear  
pg 44-46



I Love You Cat  
pg 47-49



Labrador with Heart  
pg 50-52



Llama  
pg 53-55



Love Burst  
pg 56-58



LOVE Color Wheel  
pg 59-61



Penguins  
pg 62-64



Rose  
pg 65-67



Sock Monkey  
pg 68-70



Teddy Bear  
pg 71-73



Teddy holding Heart  
pg 74-76



Unicorn  
pg 77-79

# FAQ for “Valentine Drawings”

## 1. Why are the tutorials formatted for a 6” x 9” sheet of paper?

If you fold a 9” x 12” sheet of drawing paper in half, each drawing project will make a nice Valentine card. Another option is to work on cut sheets of 6” x 9” paper and add your finished art to your Recycled Art Journal when complete.

## 2. What is a Recycled Art Journal?

After looking for years for an easy and inexpensive journal system for my 500+ students, I discovered that half sheets of drawing paper, punched with two holes on one end, held together by book rings, made a journal that could grow throughout the year. It got its name from using old cardboard for the covers.

Here are a few of the reasons why I like this system so much:

**It saves money.** Each journal requires only two book rings per student, art paper cut in half, a paper cutter, and a two-hole punch. The covers are free if you recycle by having students bring in old cereal boxes, toy boxes, etc.

**It saves time.** No more sorting of artwork. Each student is responsible for finding their journal and putting away their own art at the end of each class.

**It cuts down on unfinished student work.** The 6” x 9” paper is much easier to finish than the usual 9” x 12” size, especially if your art class is 45 min. or so. Have early finishers? They can easily flip back and work on incomplete projects.

**It helps art get home safely.** Single projects that go home in backpacks often get folded and beat up in the process. This guarantees some protection for the art until the end of the year.

**Parents love it.** They can save all their child’s work in one place too.

**Watching journals grow instills a sense of pride.** Students start to appreciate that some things take time, like making a large book of one’s own art.

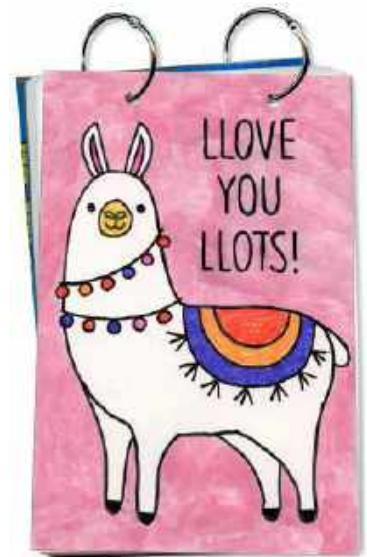
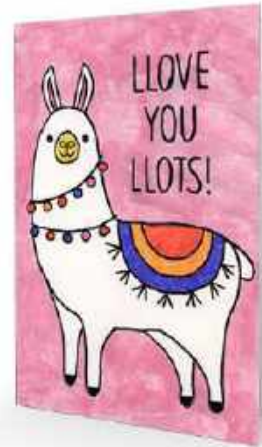

### 3. What do you need to make Recycled Art Journals?

**Cardboard.** 6" X 9". Some options are old cereal boxes, toy boxes, anything that is clean, large and easy to cut with a paper cutter. Plain cardboard is good too.

**Paper.** 6" X 9". Easy if you start with 9" x 12" and then just cut in half.

**Paper Cutter.** I prefer the old dangerous type with the arm that comes down, because it works fast and cuts through even heavy cardboard. The sliding arm type works too though, especially if you stick to lighter weight food boxes.

**Two-hole Punch.** There are many types, all seem to work well. Mine came from Staples, cost about \$15, and lasted for years.

**Book Rings.** If you just need a few, Staples sells 16 for \$5. If you need bulk, try searching Amazon. I found boxes of 100 for \$10. I recommend the 1.5" size so your journal has room to grow.



### 4. What media is recommended for these Valentine tutorials?

You could certainly use crayons or markers for these tutorials, but the Valentine theme offers a good excuse for mixing pretty pinks and pastels.

I recommend tracing the main drawing with a RediSharp permanent marker (they don't bleed through and make the inside of your card look bad) and a thin Sharpie for smaller details.

I used Prang Oval 16 Watercolor paints on watercolor paper to make my sample art. The 16 color palette, including white, offers all sorts of color mixing options.



Bird and Envelope

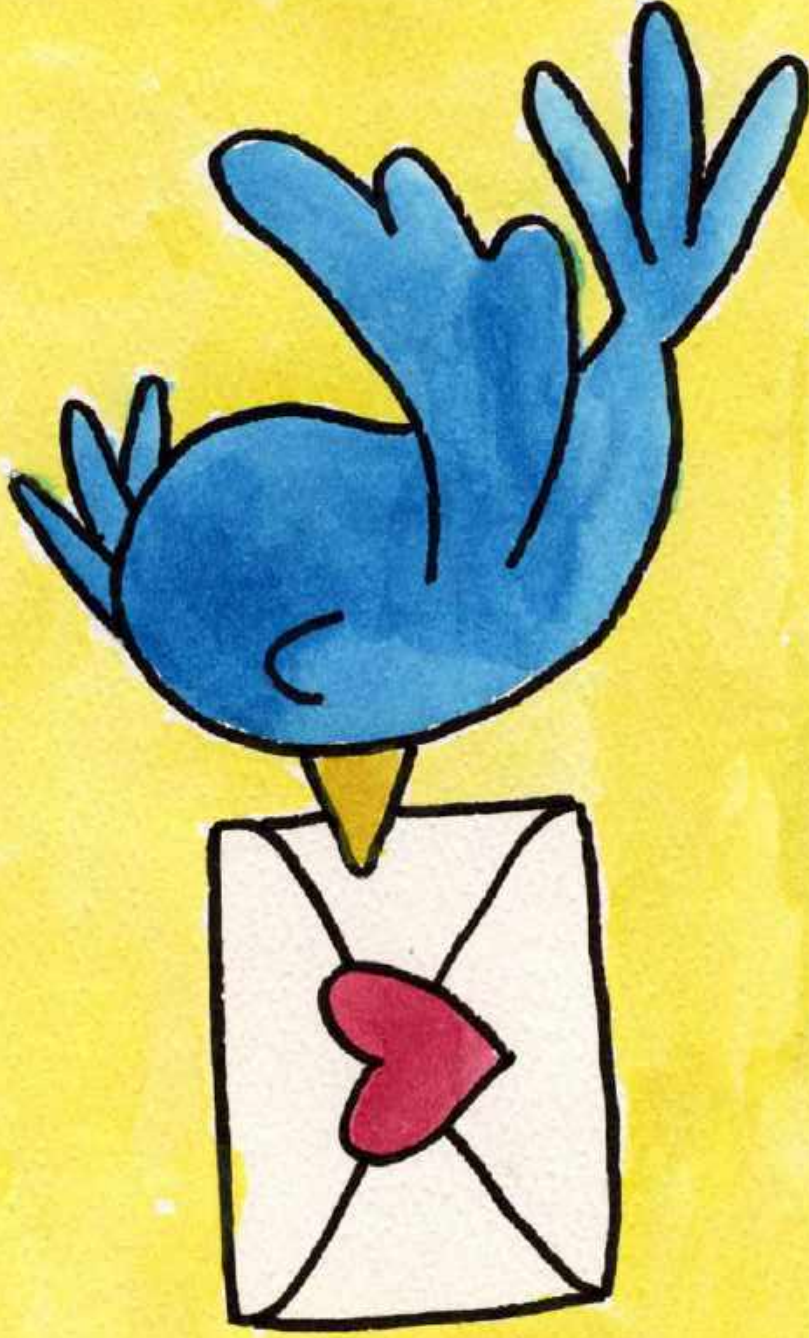

BE MY VALENTINE

# Bird and Envelope Tutorial

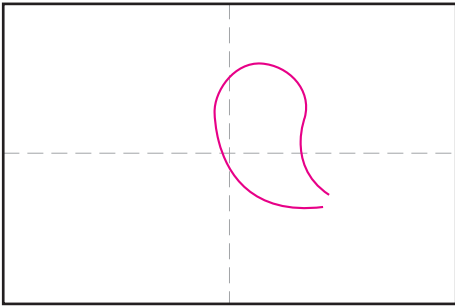

1. Fold to make guide lines. Start the bird body.

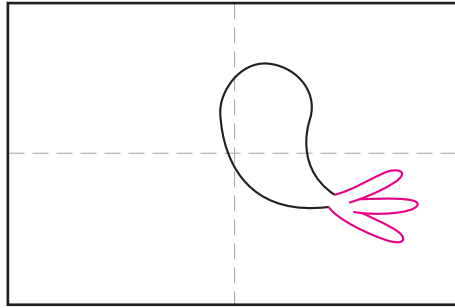

2. Add a tail.

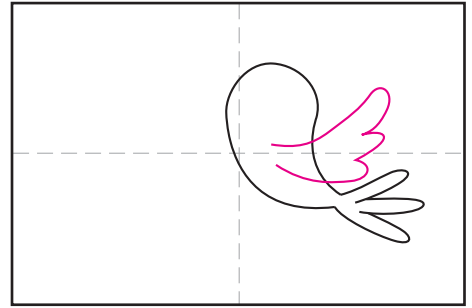

3. Draw the wing.

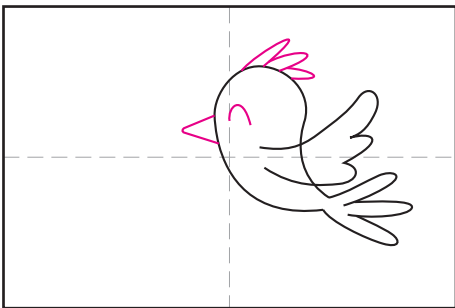

4. Add the head details.

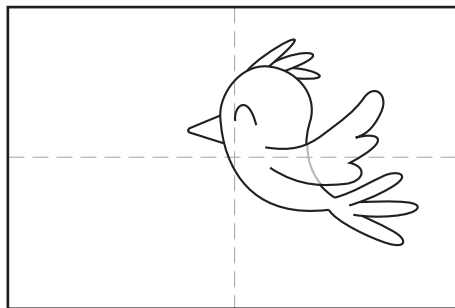

5. Erase the line inside the wing.

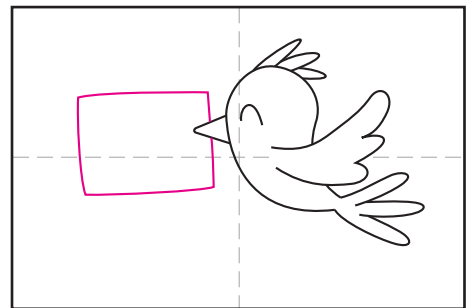

6. Draw a rectangle around the bird's beak.

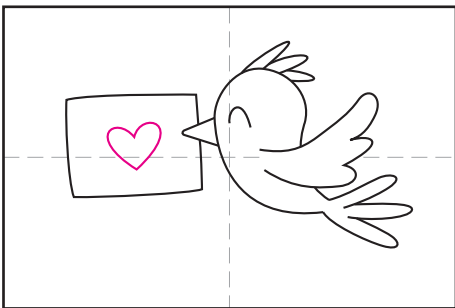

7. Add a heart in the middle.

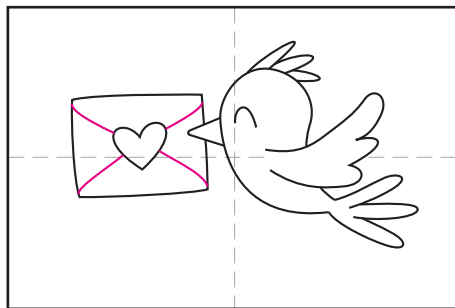

8. Connect the heart with envelope lines.

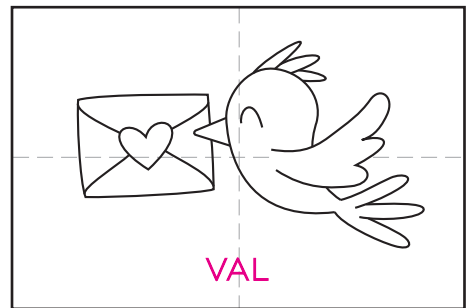

9. Start the message with "VAL" centered in the middle.

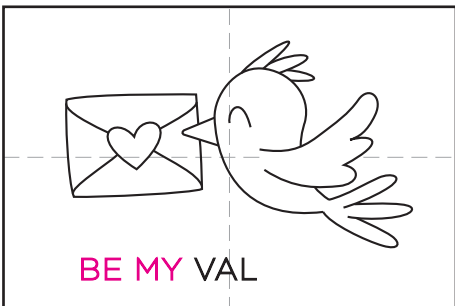

10. Add "BE MY" to the left.

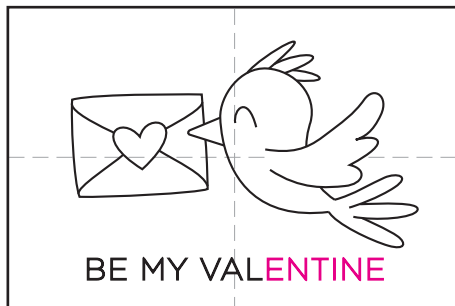

11. Add "VALENTINE" to the right.



12. Trace with a RediSharp black marker and paint with Prang Oval 16 watercolors.

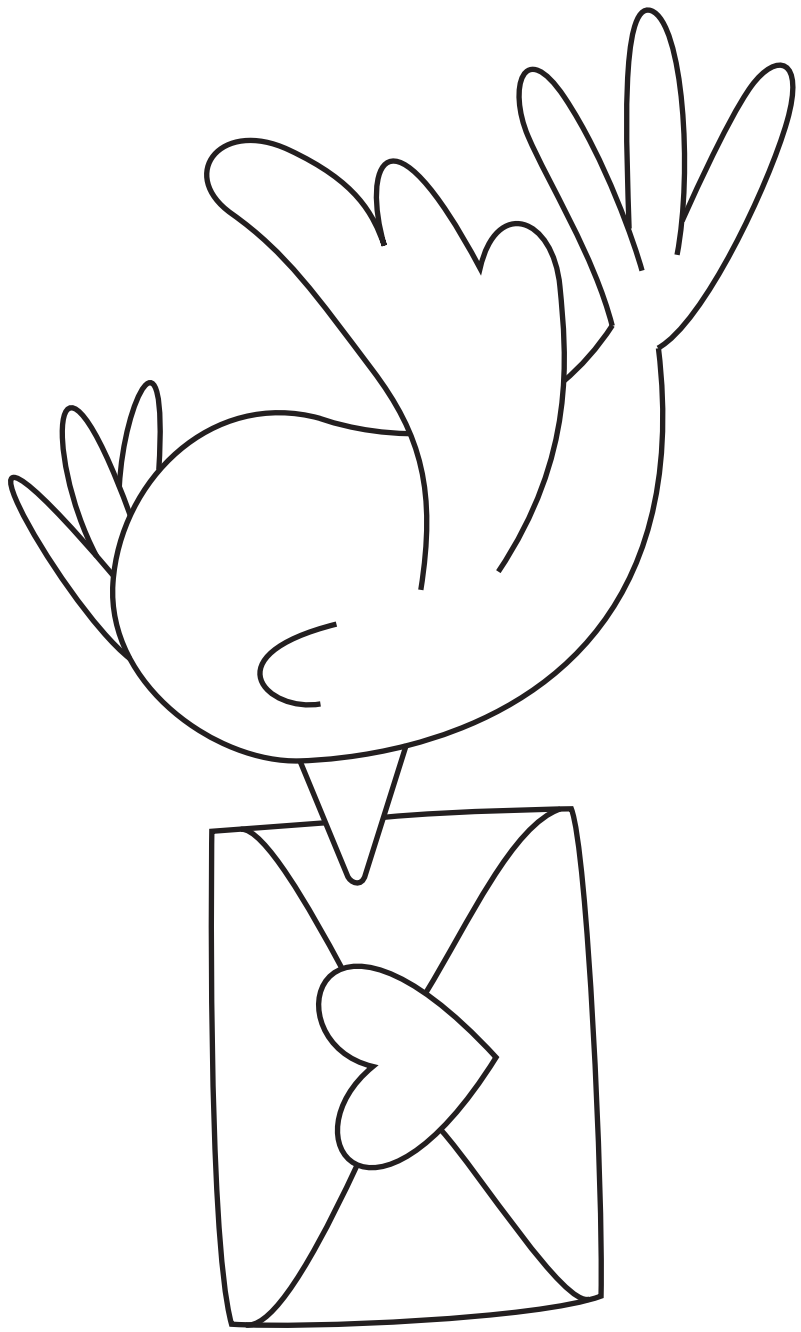

BE MY VALENTINE

# Candy Hearts

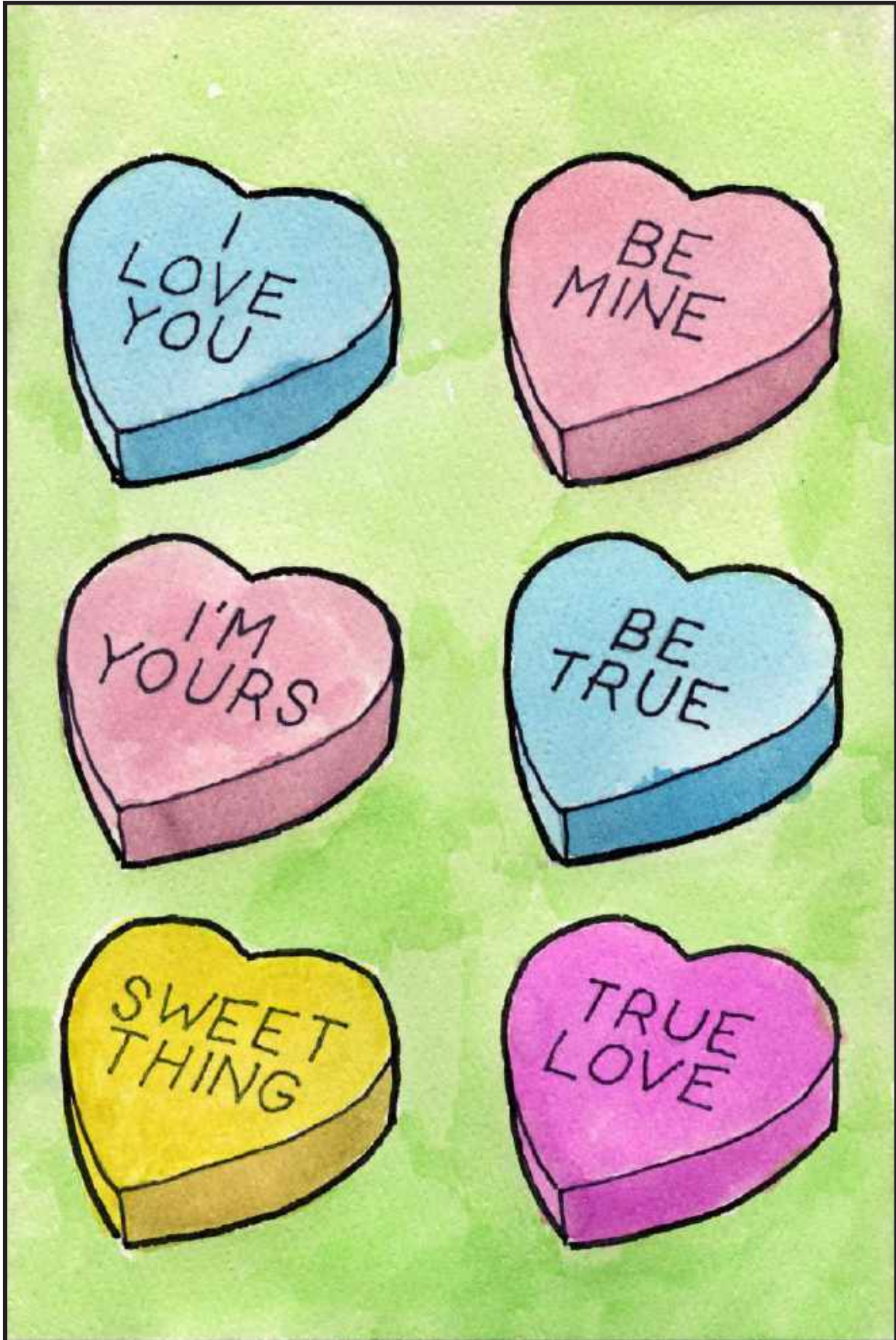

# Candy Hearts Tutorial

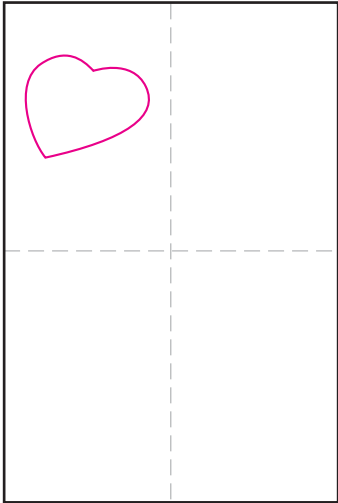

1. Fold to make guide lines. Draw the first heart at an angle.

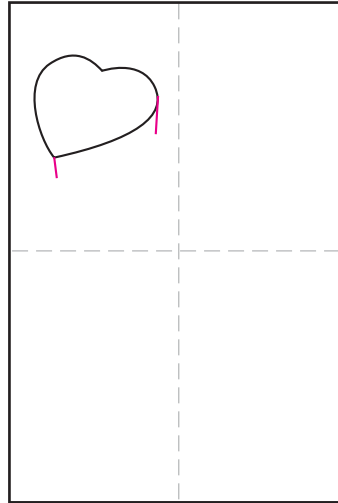

2. Draw the vertical side lines.

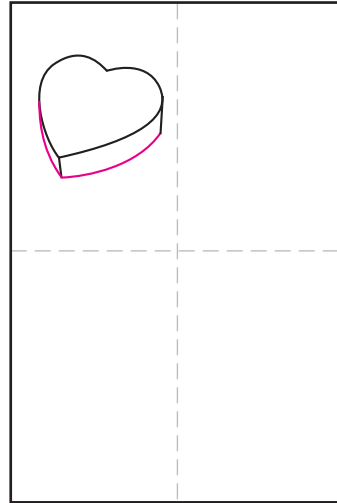

3. Draw the bottom curved edge.

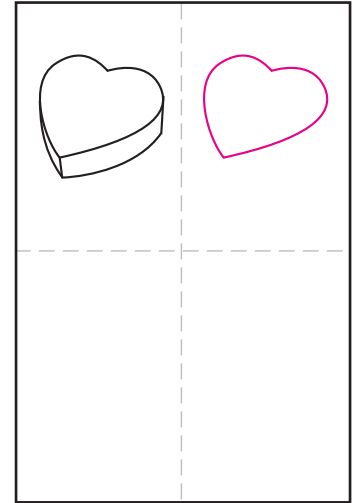

4. Draw another heart.

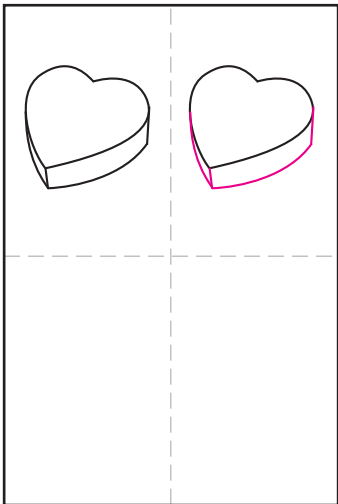

5. Draw the vertical lines and bottom edge.

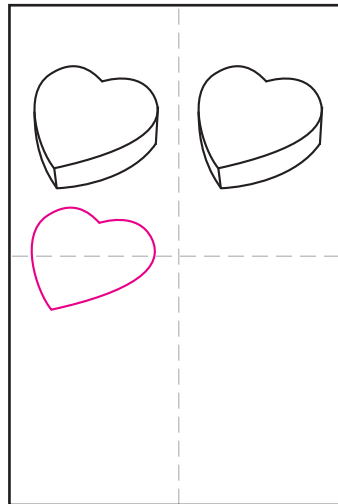

6. Draw another heart.

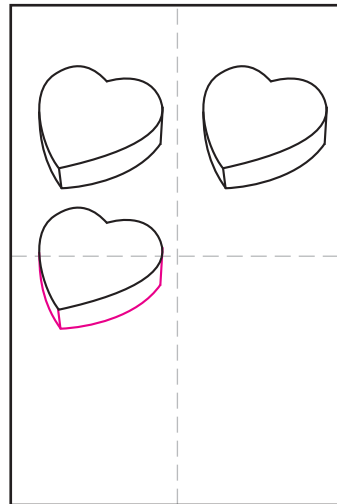

7. Draw the vertical lines and bottom edge.

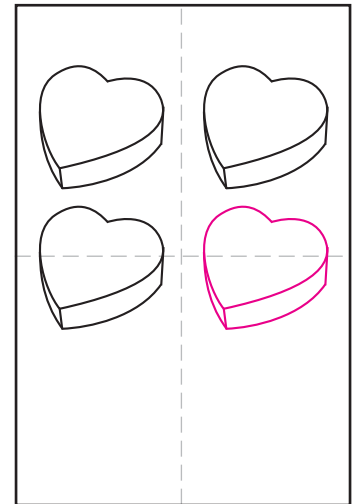

8. Follow the steps to draw a fourth heart.

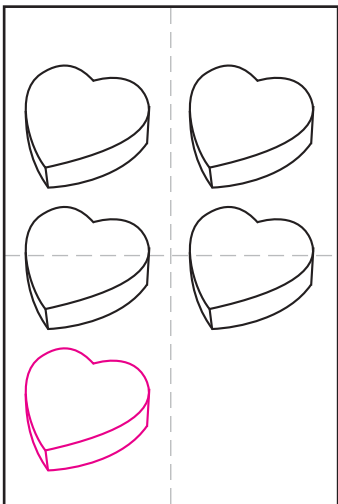

9. Follow the steps to draw a fifth heart.

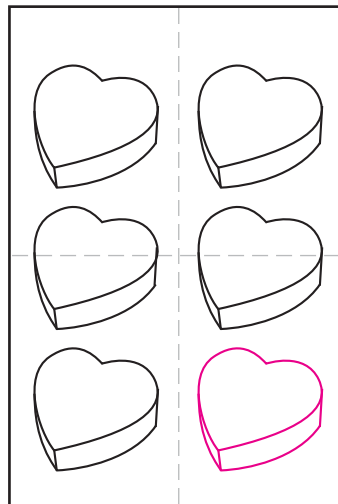

10. Follow the steps to draw a sixth heart.

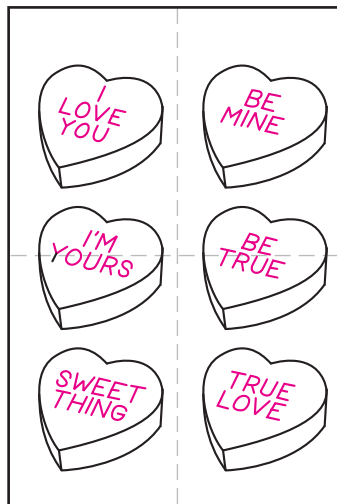

11. Add messages inside each heart. Capital letters work best.



12. Trace with a RediSharp black marker and paint with Prang Oval 16 watercolors.

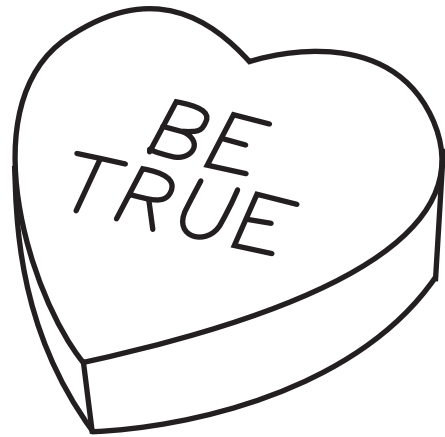

# Cat with Balloons



# Cat with Balloons Tutorial

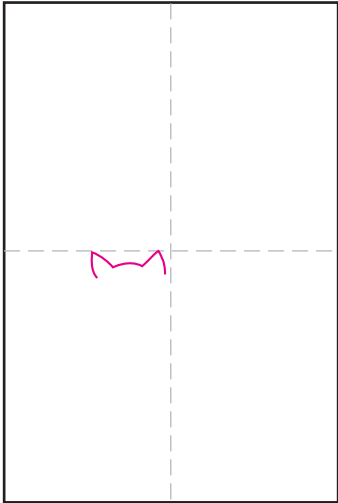

1. Fold to make guide lines. Draw the top of the head.

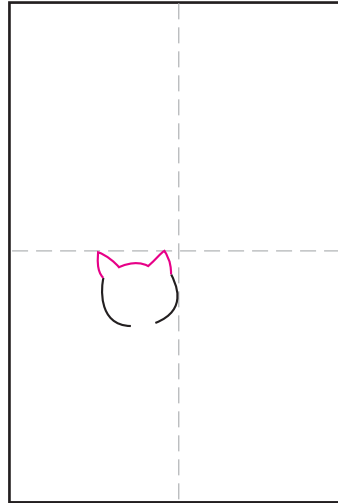

2. Draw the sides of the head.

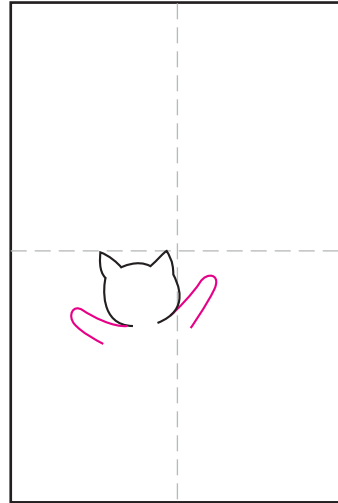

3. Add two arms.

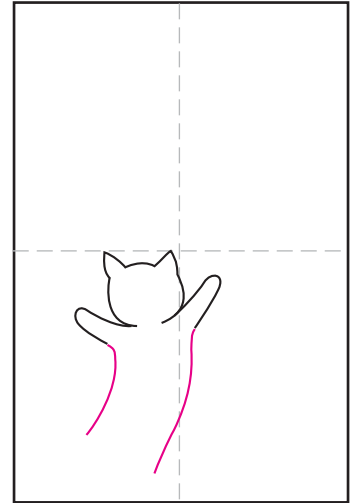

4. Continue down with the body, swerving to the left.

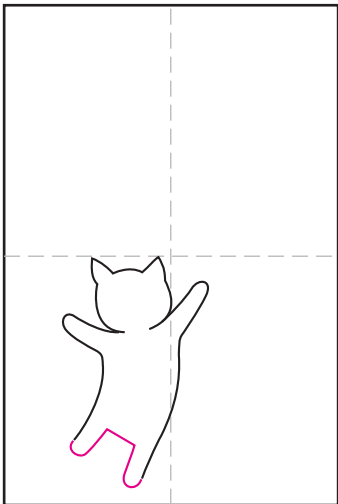

5. Finish with two legs at the bottom.

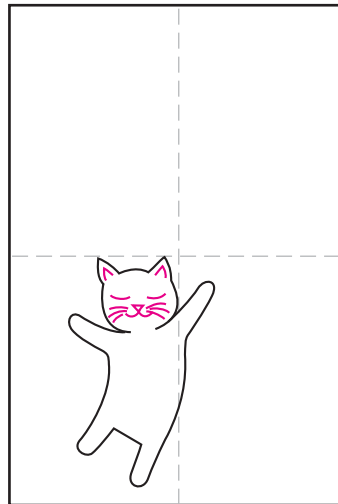

6. Draw the face inside the head.

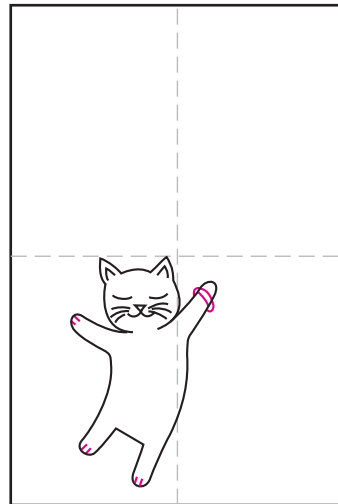

7. Add the claws and tie around the one arm.

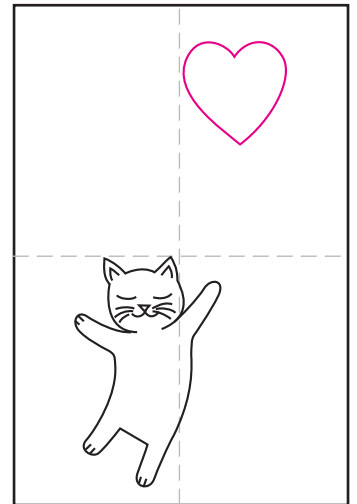

8. Draw the front balloon.

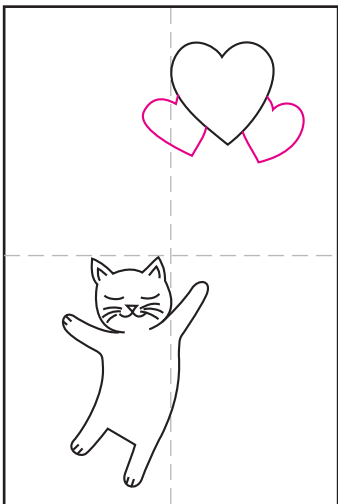

9. Draw the two back balloons.

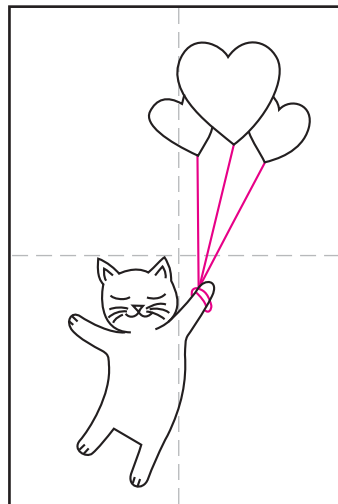

10. Attach the balloons to the arm with strings.

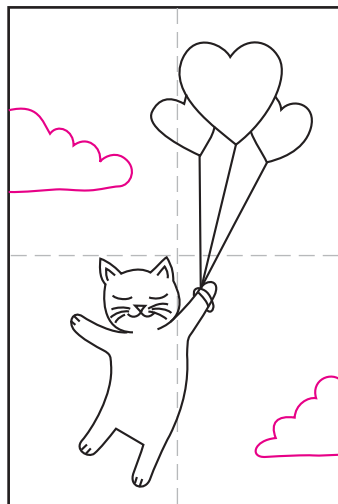

11. Draw clouds in the background.



12. Trace with a RediSharp black marker and paint with Prang Oval 16 watercolors.

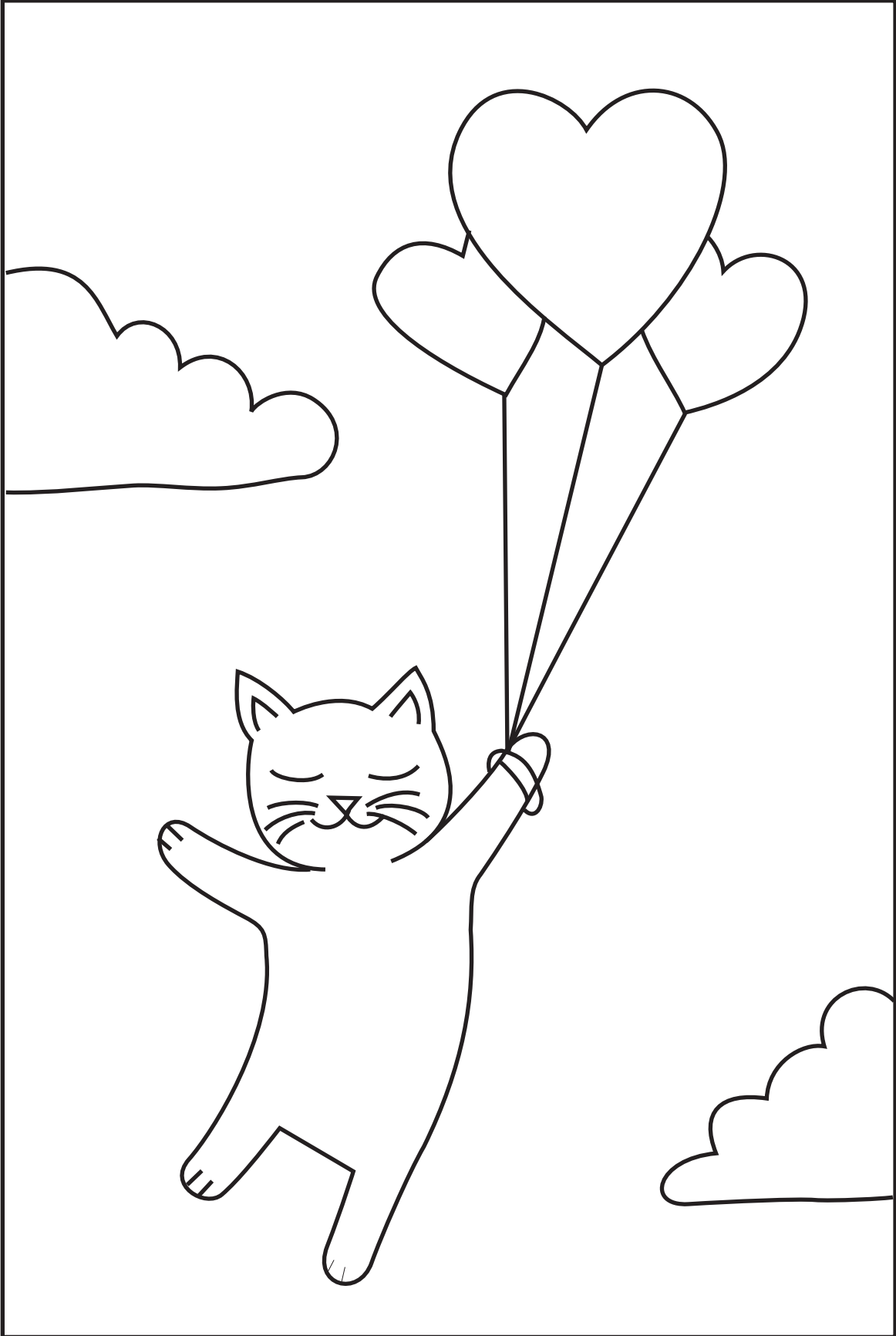

# Two Cats and a Heart

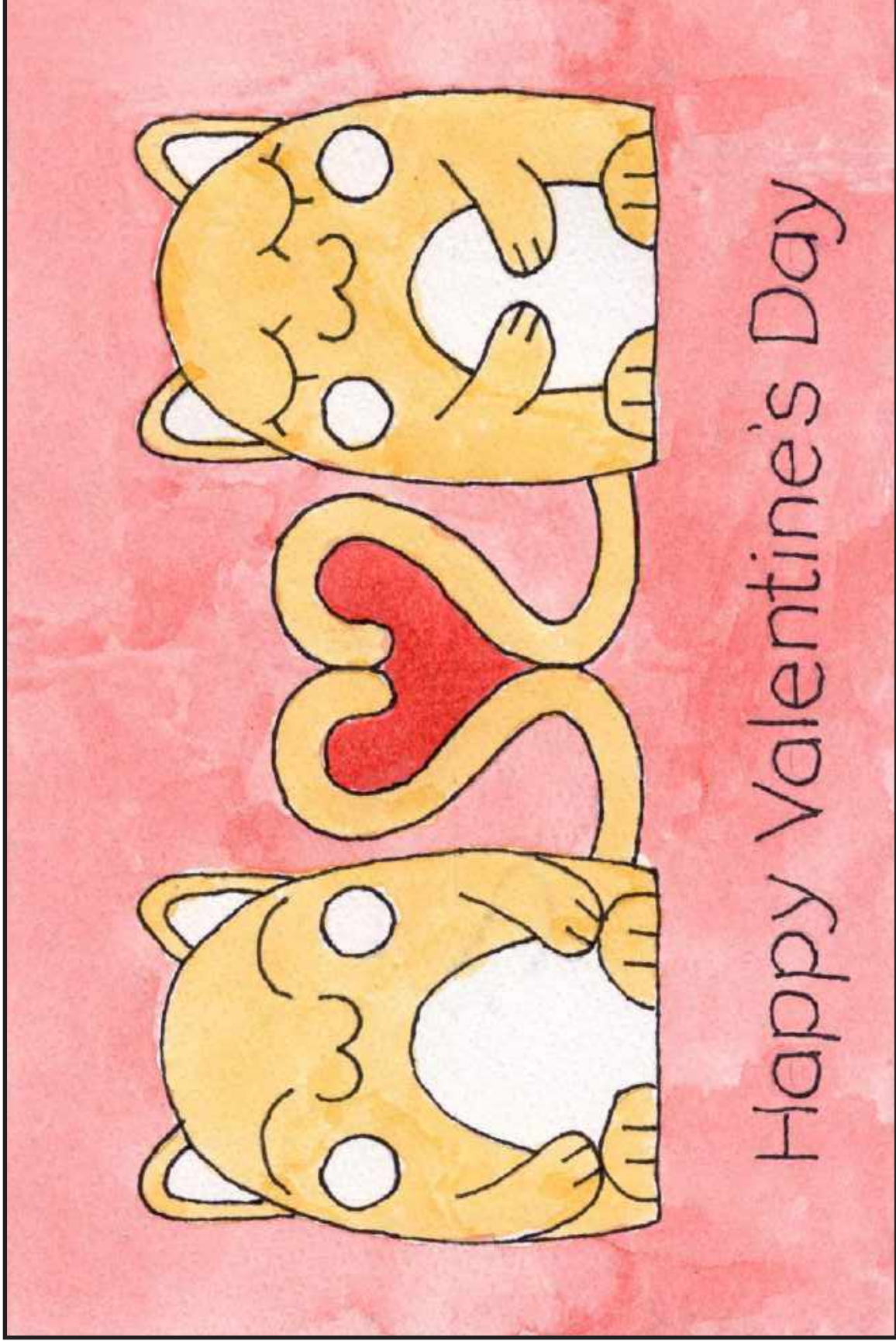

# Two Cats and a Heart Tutorial

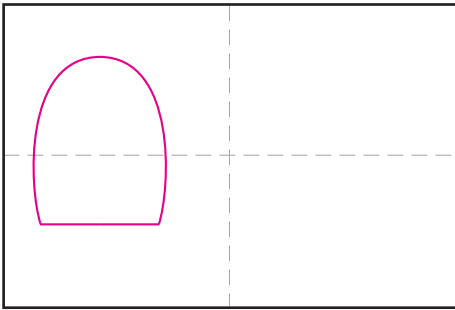

1. Fold to make guide lines. Draw the left cat body.

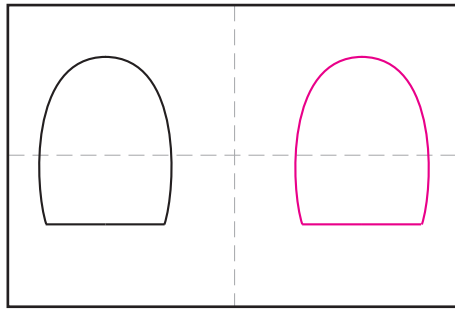

2. Draw the right cat body. Make sure they are equally spaced from the center.

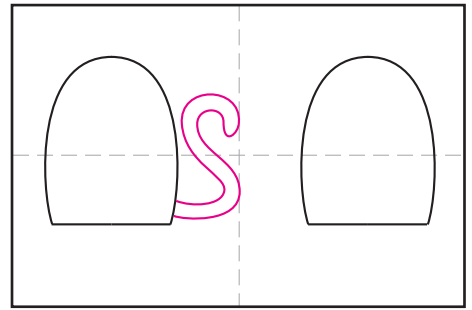

3. Draw the left tail. Make sure it just touches the center line.

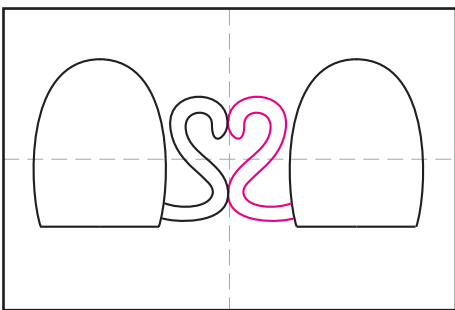

4. Draw a matching tail on the right cat. Make it as symmetrical as you can.

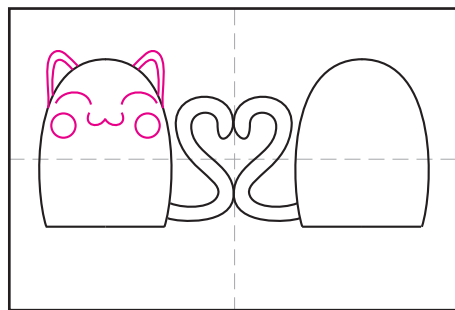

5. Draw the ears and face of the left cat.

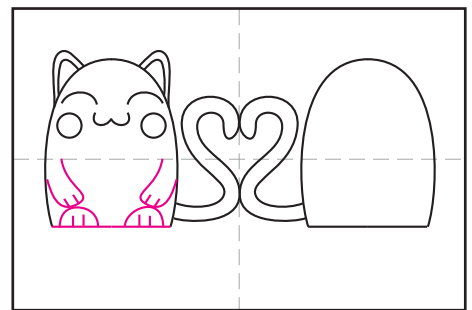

6. Add two arms and two feet.

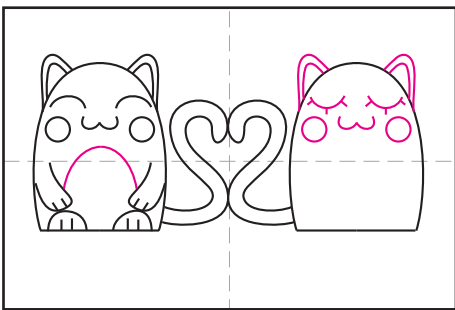

7. Add the belly line to the left cat. Draw the ears and face on the right cat.

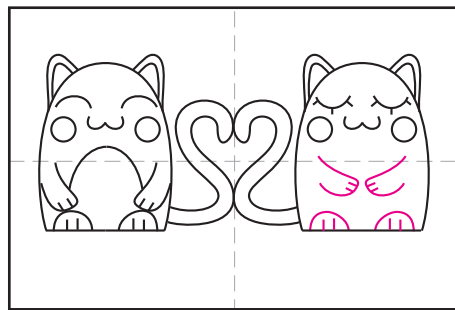

8. Add two arms and two feet.

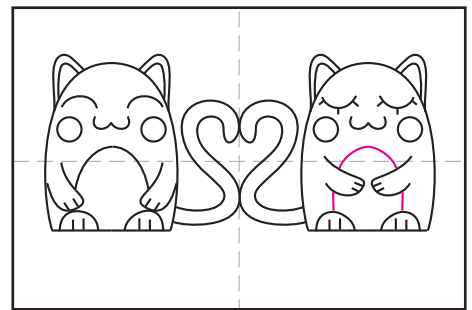

9. Finish the right cat with a belly line.

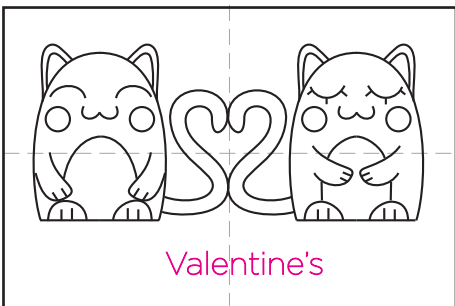

10. To make sure your words are centered when finished, start by writing "Valentine's" in the middle.

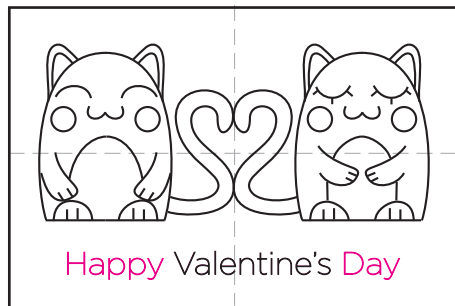

11. Add "Happy" on the left, and "Day" on the right.



12. Trace with a RediSharp black marker and paint with Prang Oval 16 watercolors.

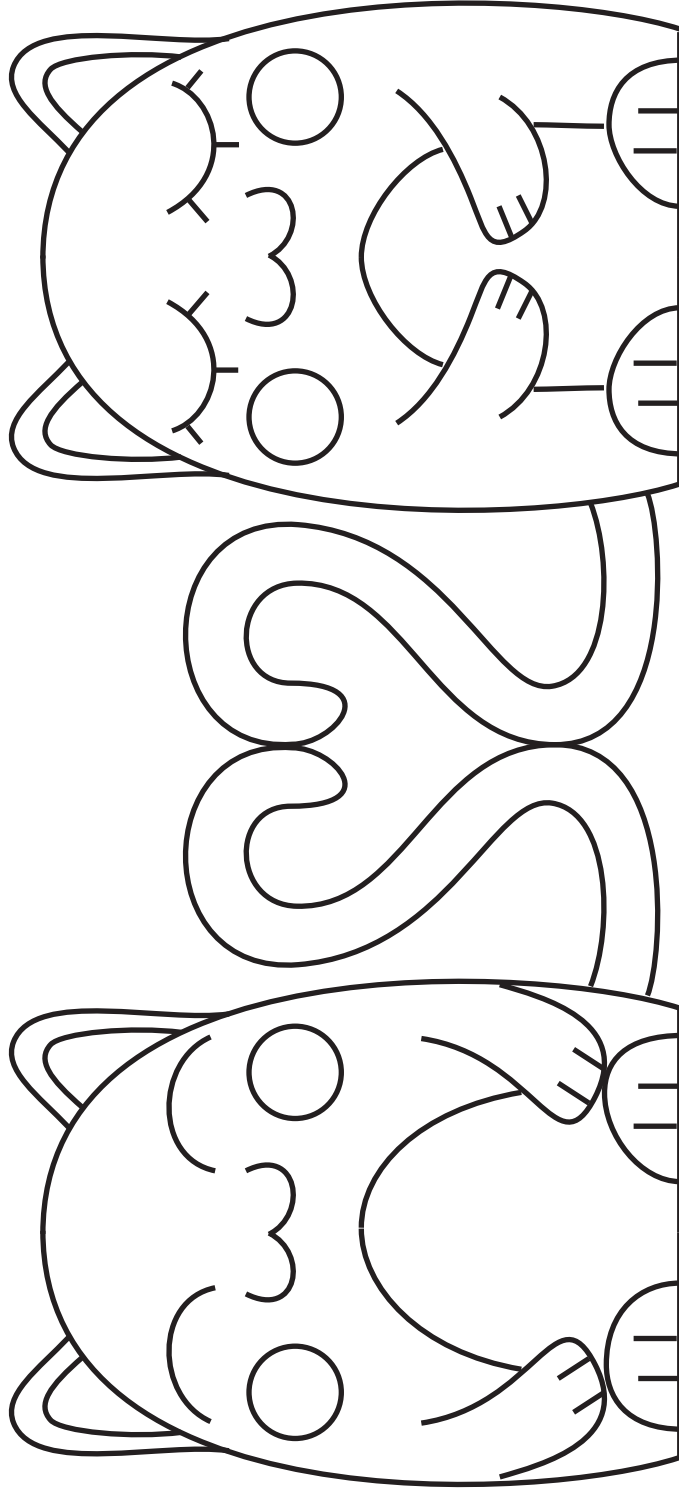

Happy Valentine's Day

# Cupid



# Cupid Tutorial

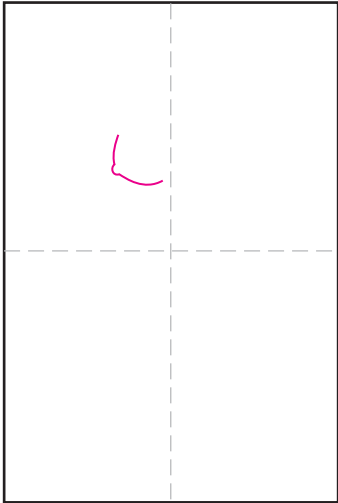

1. Fold to make guide lines. Draw the face.

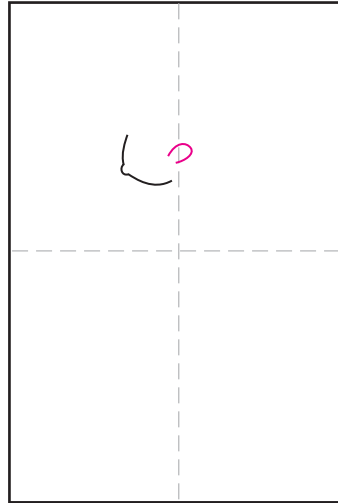

2. Add an ear.

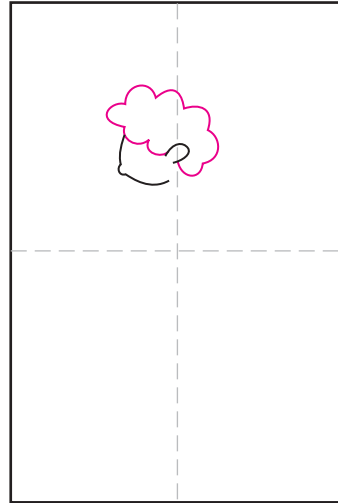

3. Draw some curly hair.

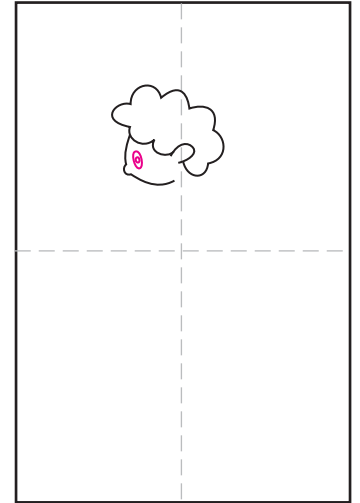

4. Add an eye.

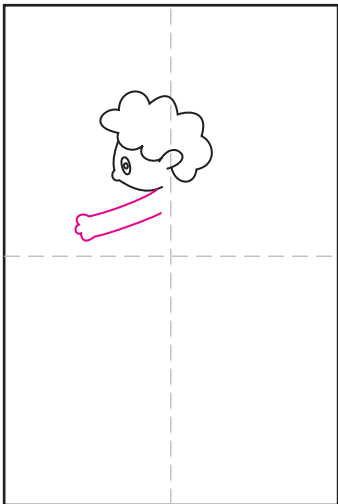

5. Draw a straight arm.



6. Add two wings in the back.

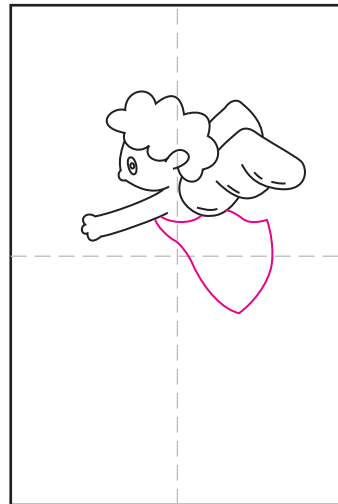

7. Draw a robe below.

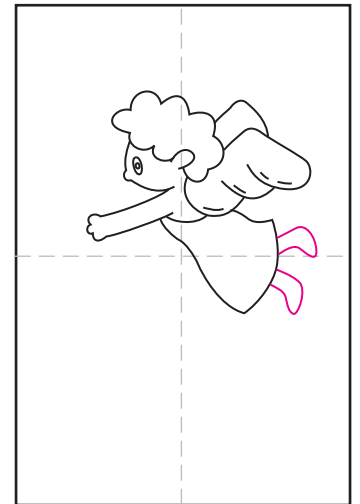

8. Draw two feet.

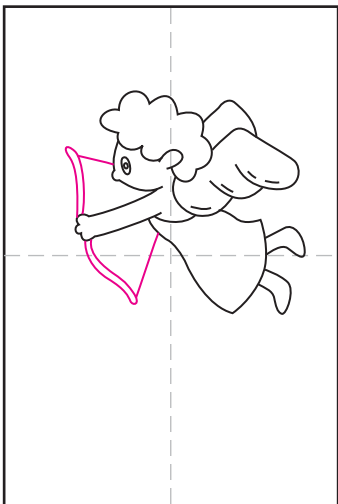

9. Draw a bow behind the arm.

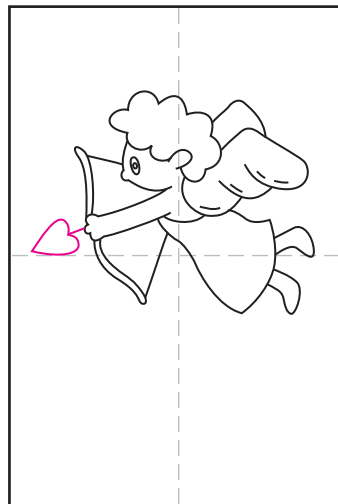

10. Add a heart arrow.

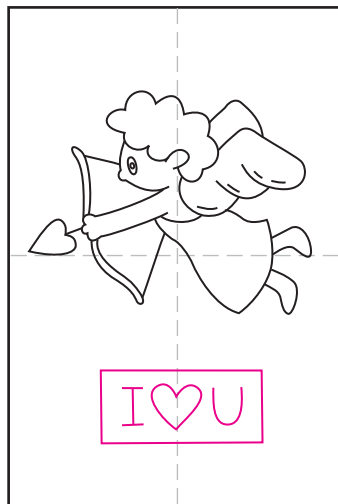

11. Add the I heart you message below.



12. Trace with a RediSharp black marker and paint with Prang Oval 16 watercolors.

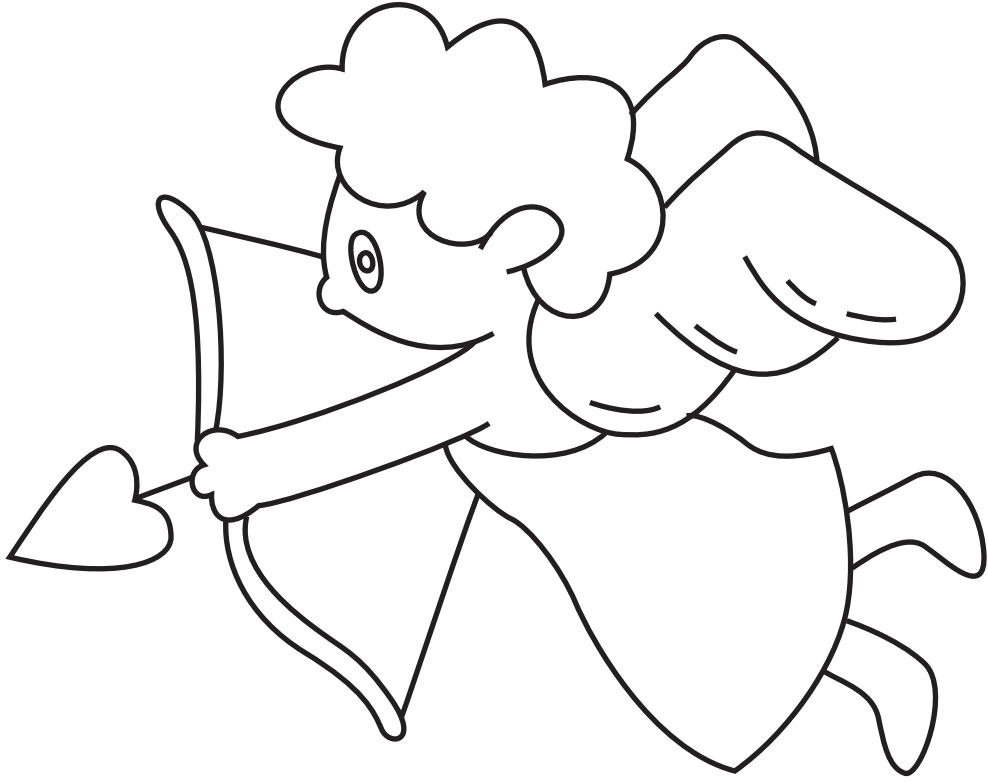

I ♥ U

# Dog in a Cup



LOVE YOU!

# Dog in a Cup Tutorial

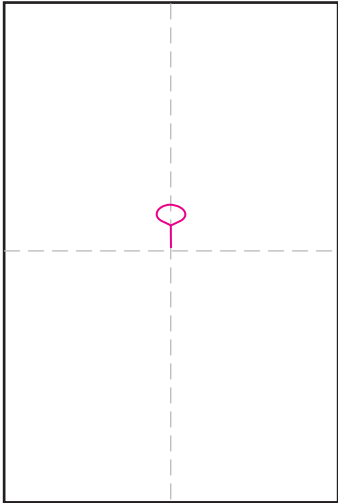

1. Fold to make guide lines. Draw the nose in the center.

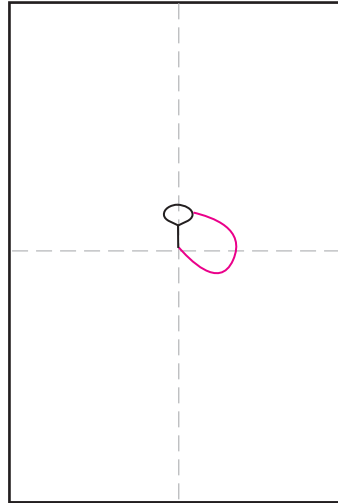

2. Add the right side of the muzzle.

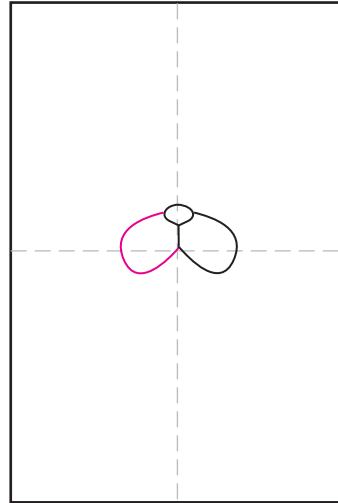

3. Add the left side of the muzzle.

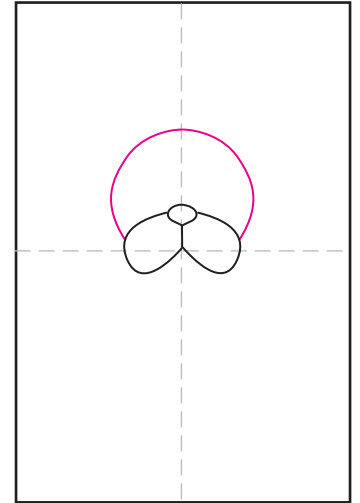

4. Draw the round head above the muzzle.

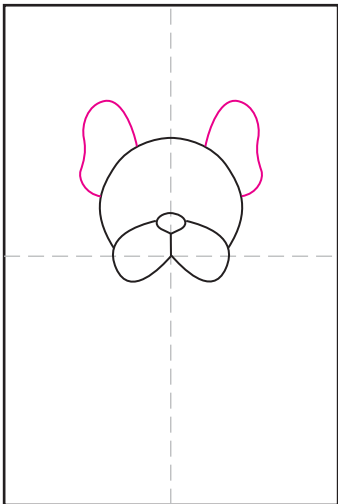

5. Draw two symmetrical ears.

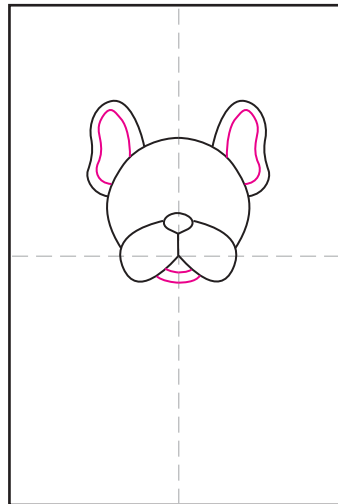

6. Add the inside ear shapes, and the chin.

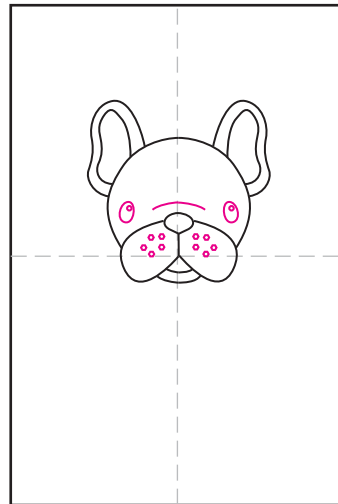

7. Draw two eyes, and nostril line and spots.

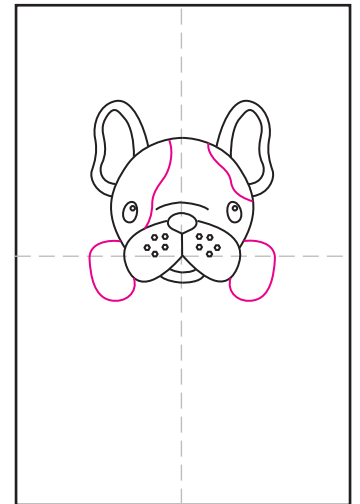

8. Add color patch lines and two paws.

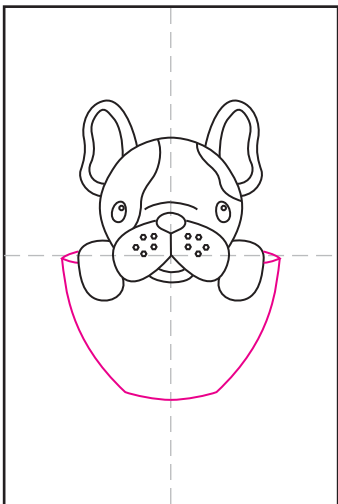

9. Draw a cup below the body.

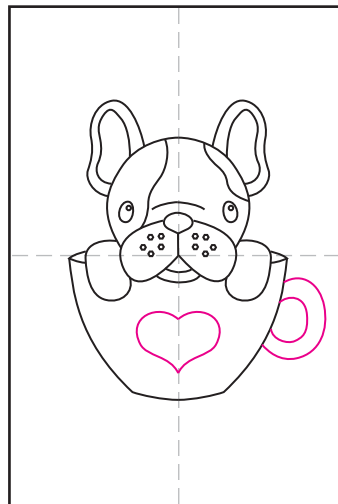

10. Add a heart and handle to the cup.

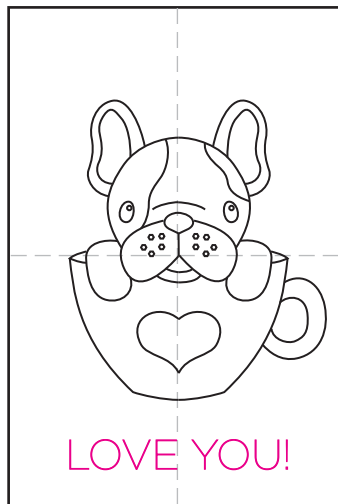

11. Write "LOVE YOU!" or some other message below.



12. Trace with a RediSharp black marker and paint with Prang Oval 16 watercolors.

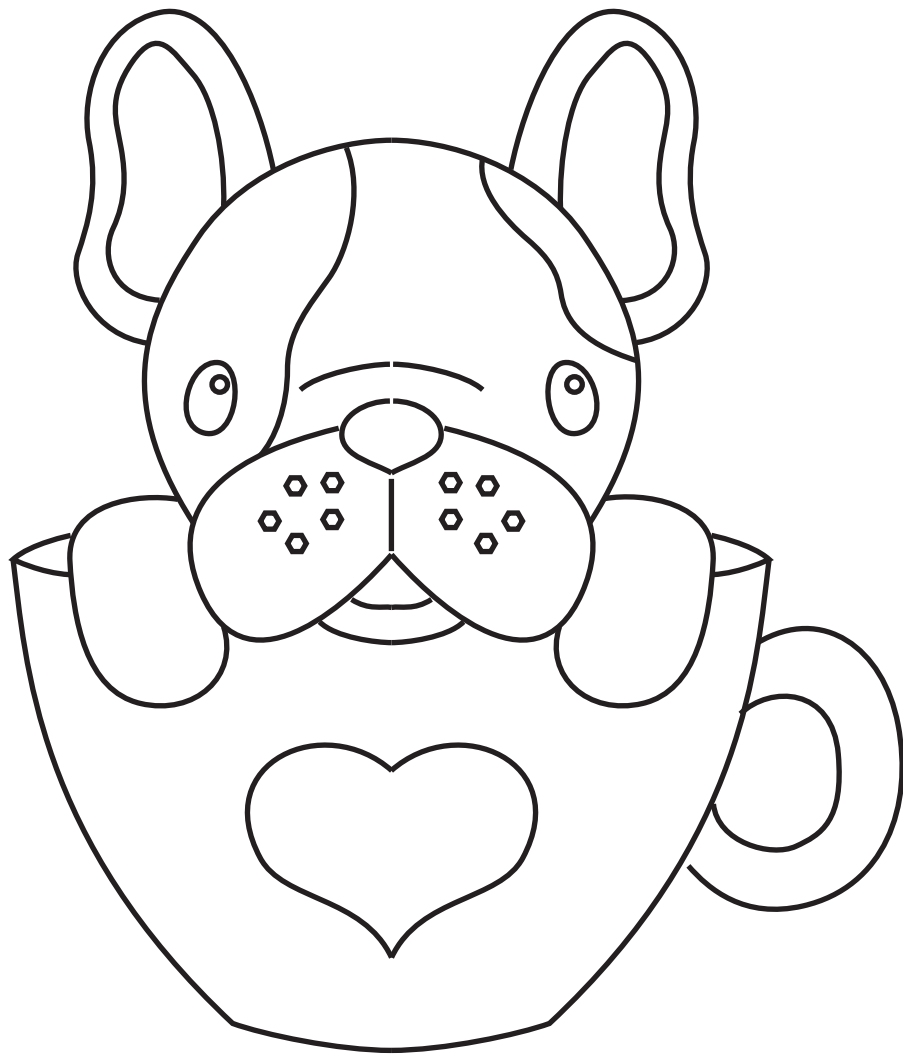

LOVE YOU!

# Elephant and Hearts

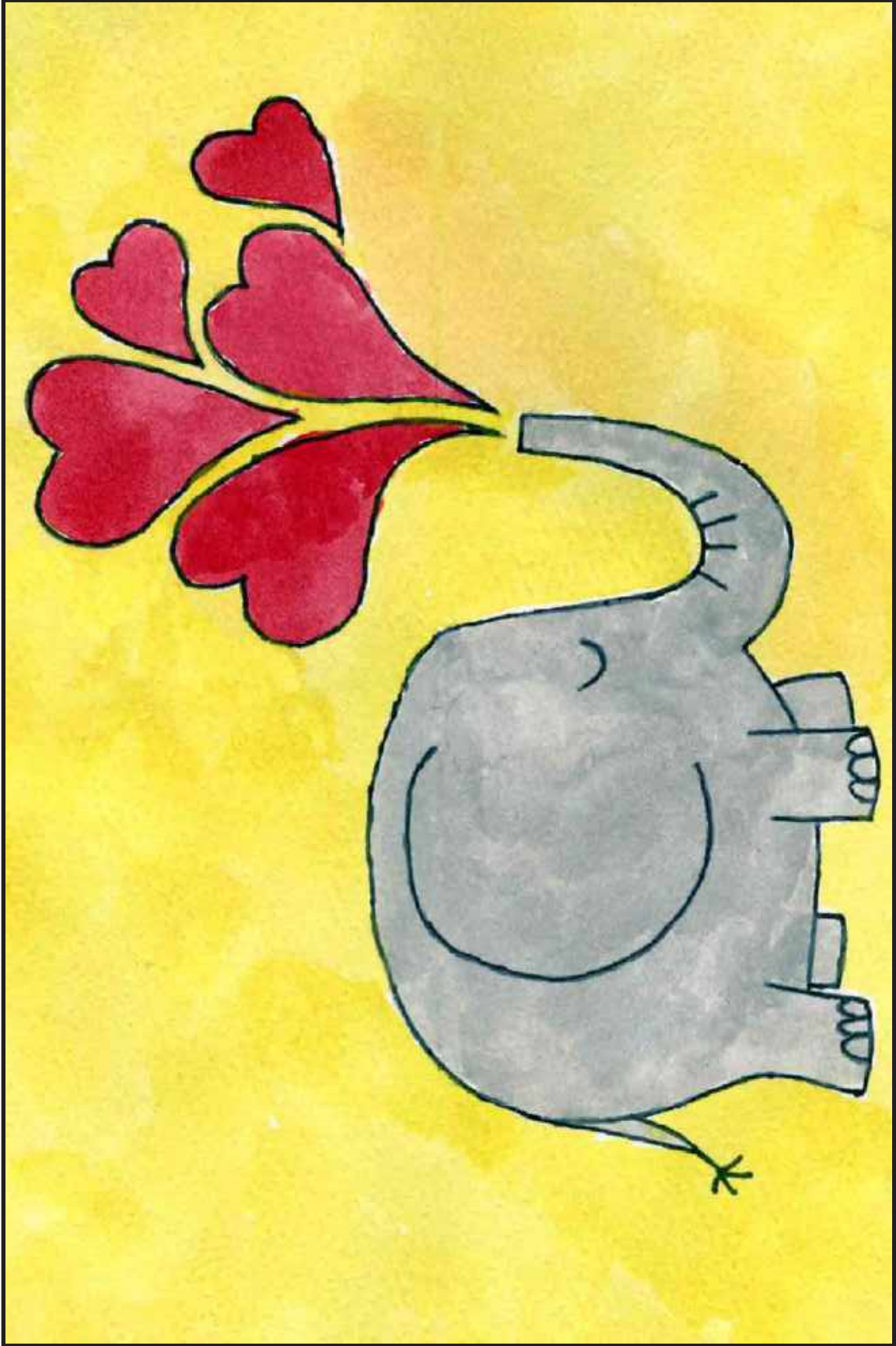

# Elephant and Hearts Tutorial

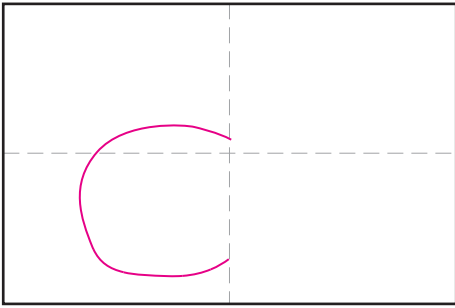

1. Fold to make guide lines. Start the elephant body.

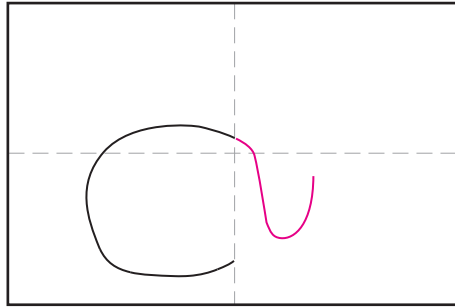

2. Continue in front with a curve of a trunk.

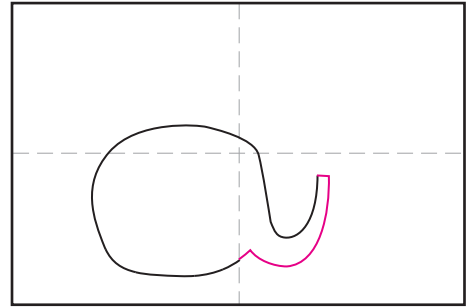

3. Add the bottom of the trunk.

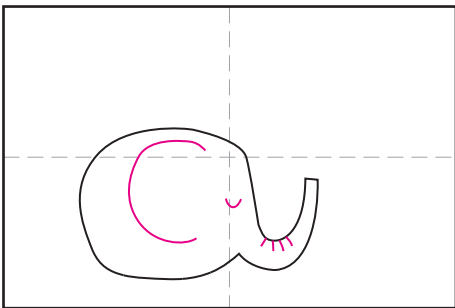

4. Draw an ear, eye and trunk wrinkles.

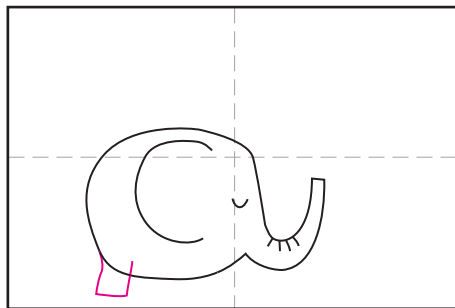

5. Draw a back leg.

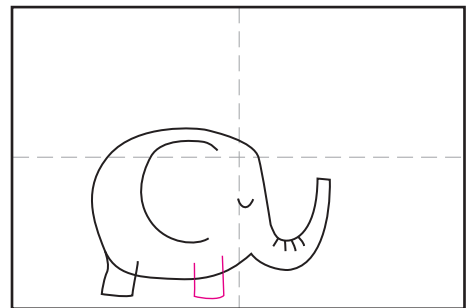

6. Draw a front leg.

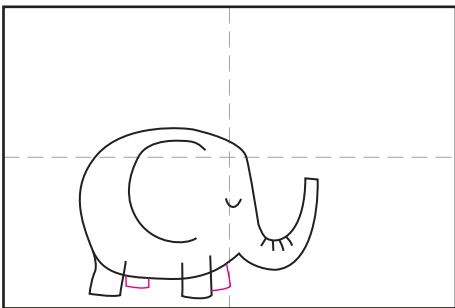

7. Add two more legs. They should be a bit shorter because they are further away.

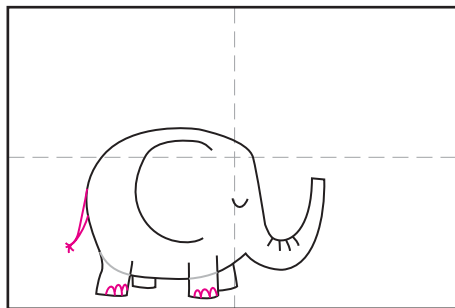

8. Add toenails and a tail. Erase lines in the closer legs.

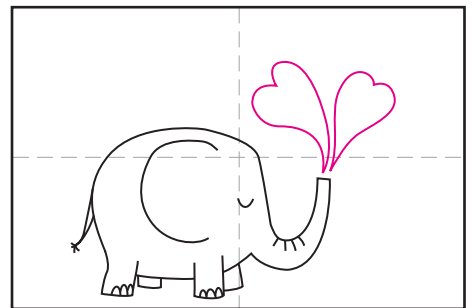

9. Draw two hearts coming out of the trunk.

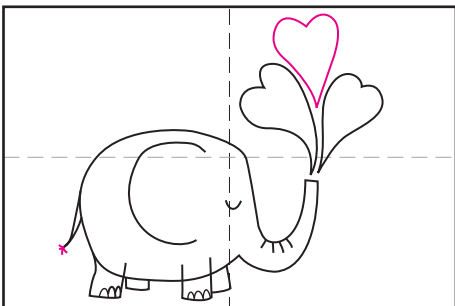

10. Add a middle heart.

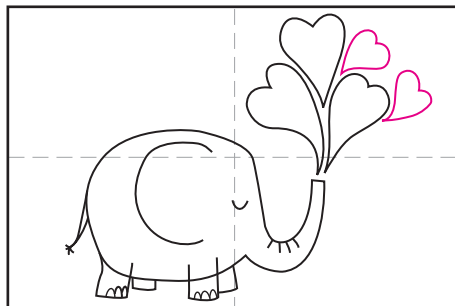

11. Draw more smaller hearts on the side.

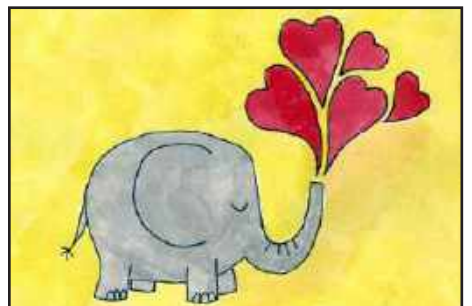

12. Trace with a RediSharp black marker and paint with Prang Oval 16 watercolors.

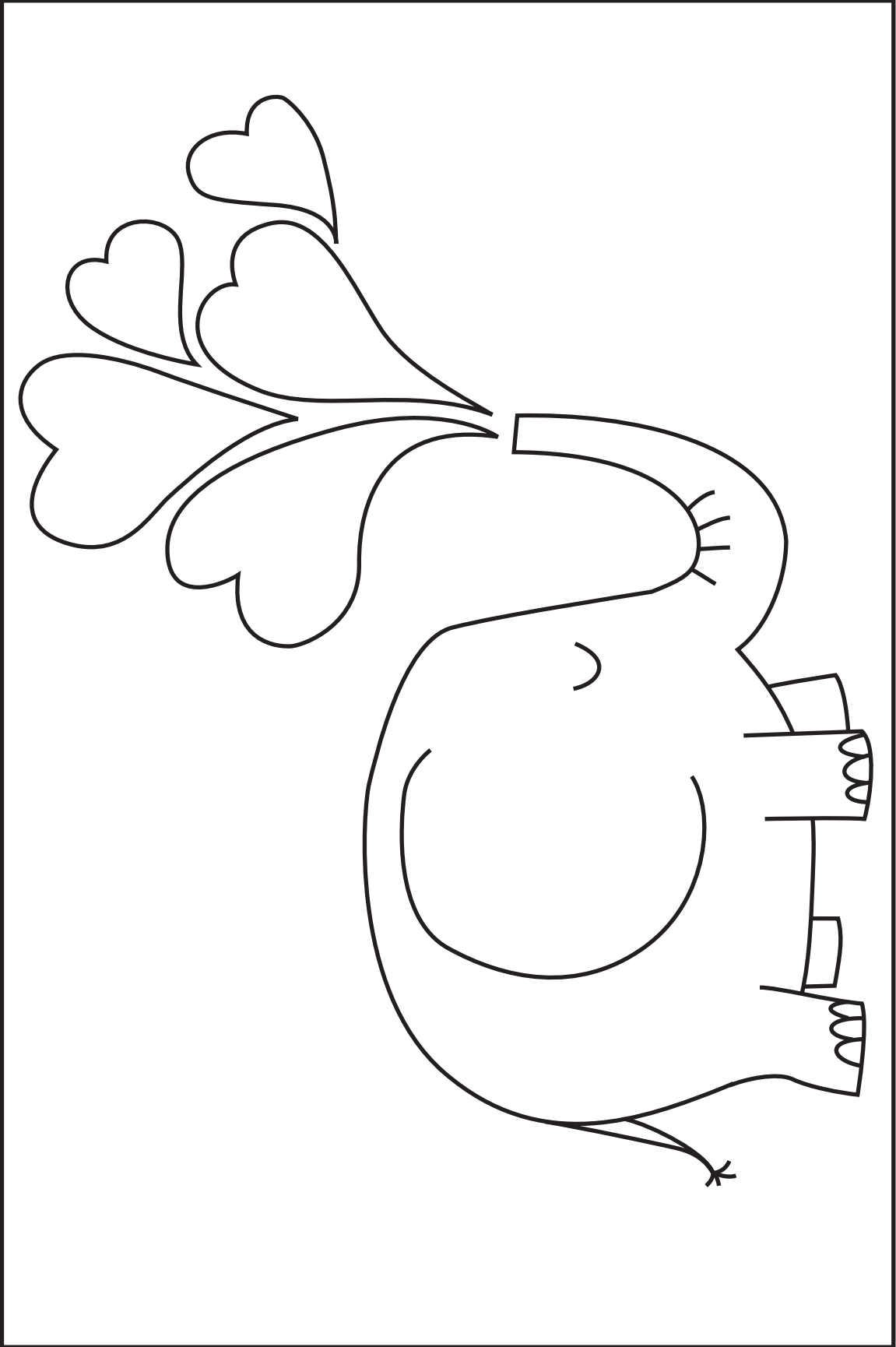

Happy Valentine's Day

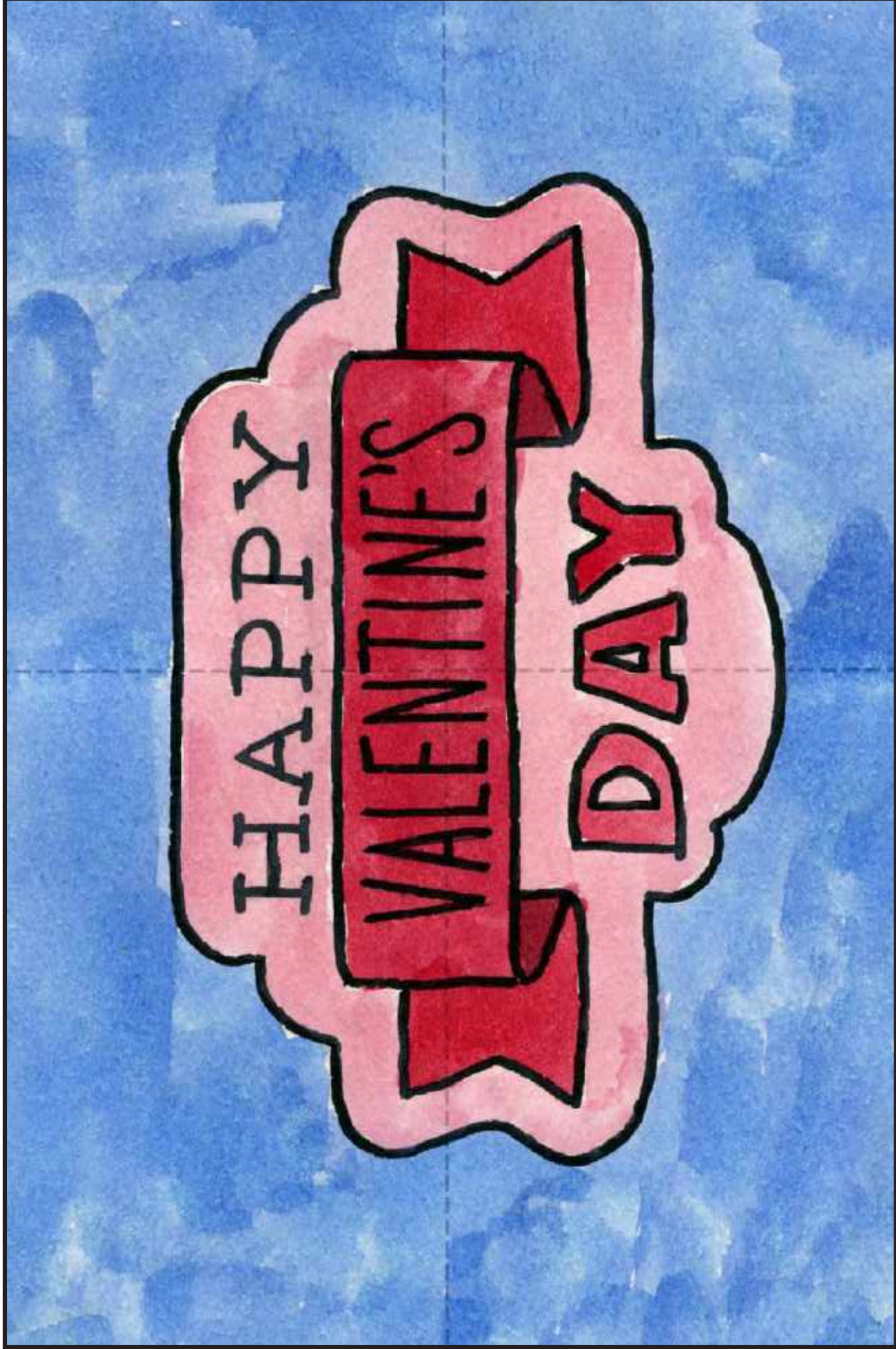

# Happy Valentine's Day Tutorial

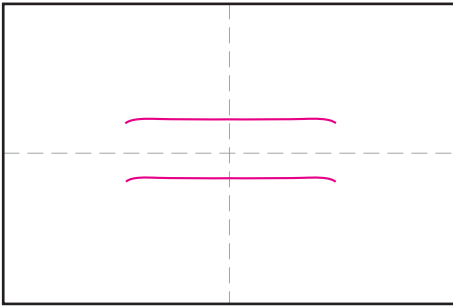

1. Fold to make guide lines. Start the center ribbon lines.

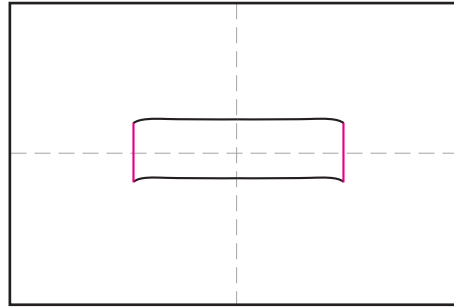

2. Connect the ends with two vertical lines.

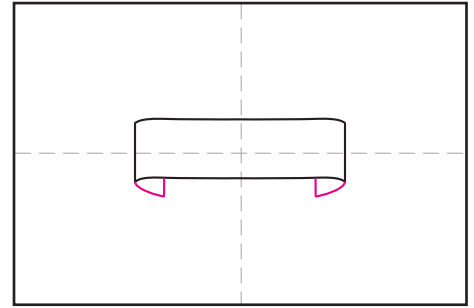

3. Draw the ribbon wrap lines.

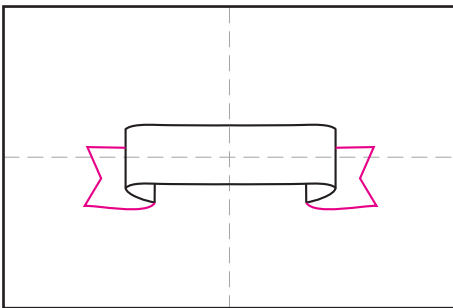

4. Draw the two ribbon ends.

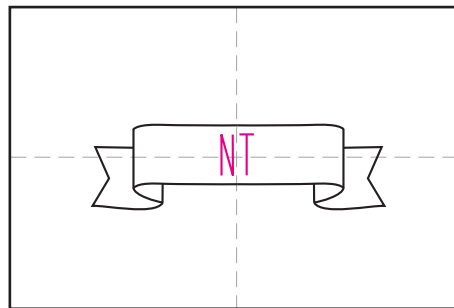

5. Start the "Valentine's" letters with the center two, N and T. It will assure that your word is centered on the ribbon.

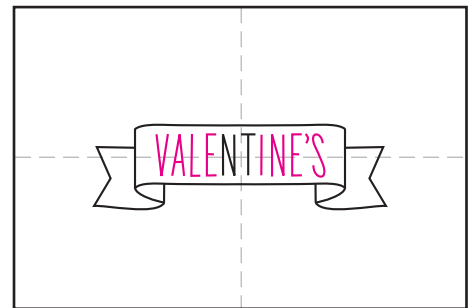

6. Complete the "Valentine's" letters to the right and left.

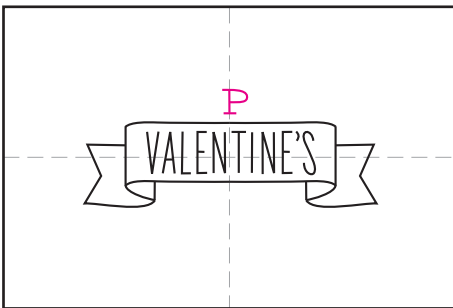

7. Start "Happy" letters with a centered P.

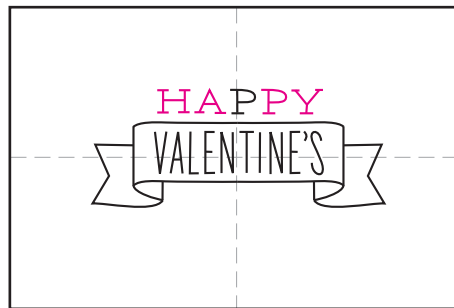

8. Complete the "Happy" letters to the right and left.

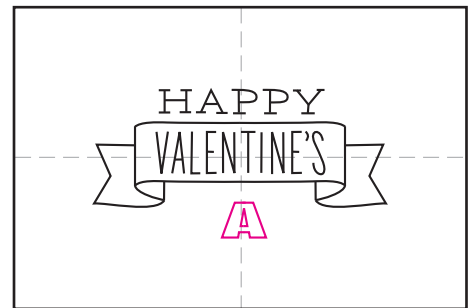

9. Start the "Day" word with a centered A.

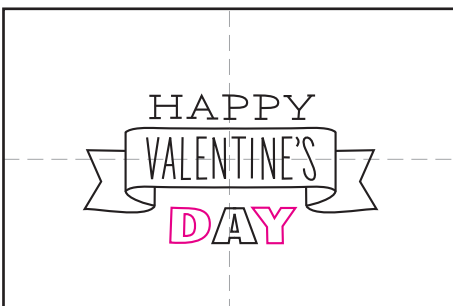

10. Complete the "Day" word to the right and left.

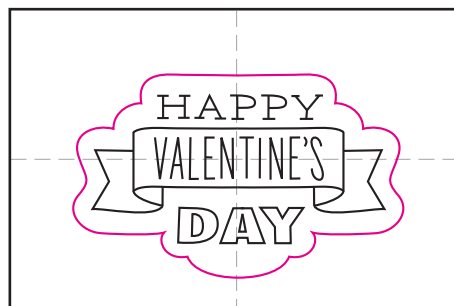

11. Draw an outline around the words and ribbon, keeping an equal distance.



12. Trace with a RediSharp black marker and paint with Prang Oval 16 watercolors.

HAPPY  
VALENTINE'S  
DAY

# Heart and Ribbon

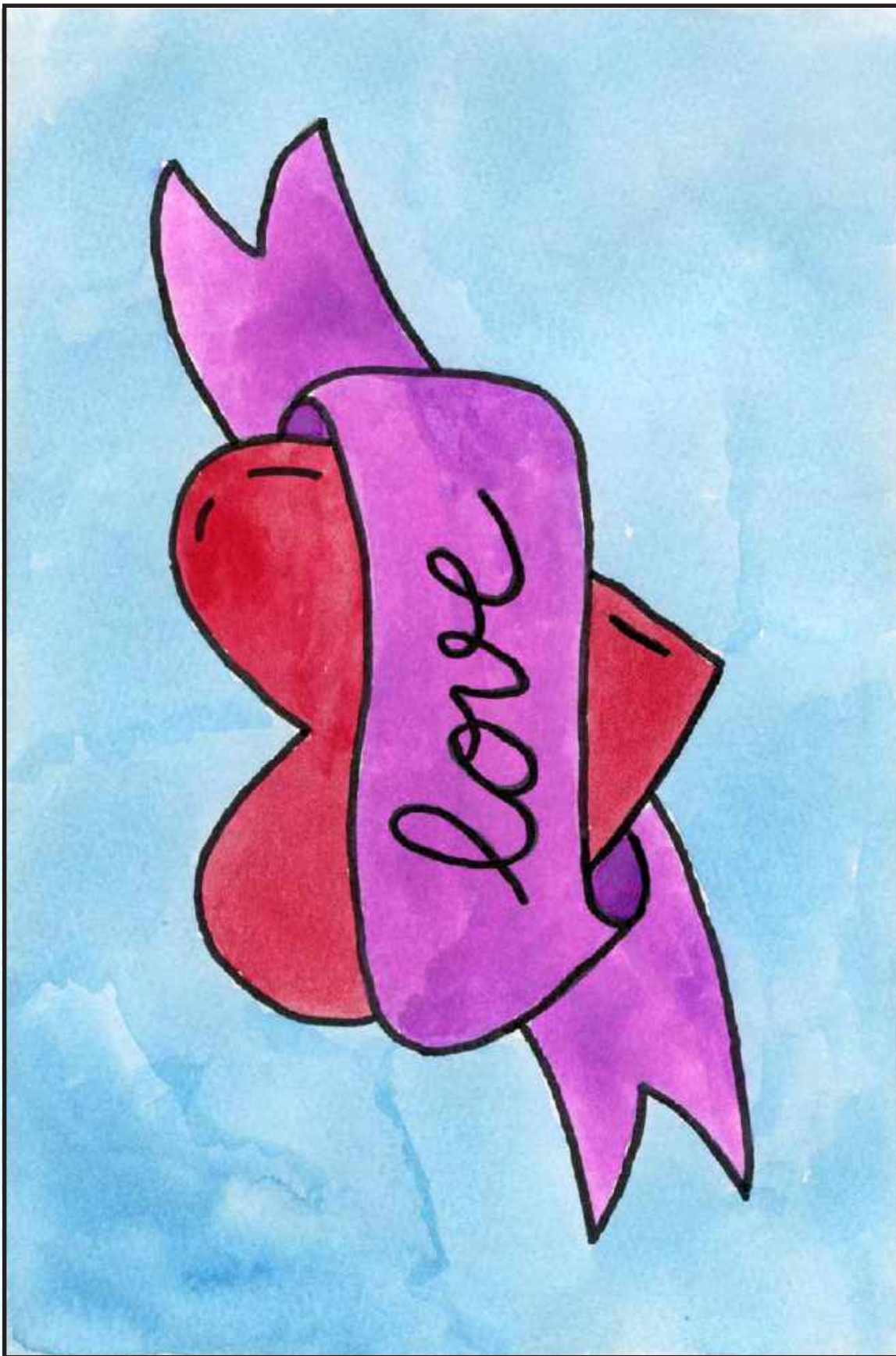

# Heart and Ribbon Tutorial

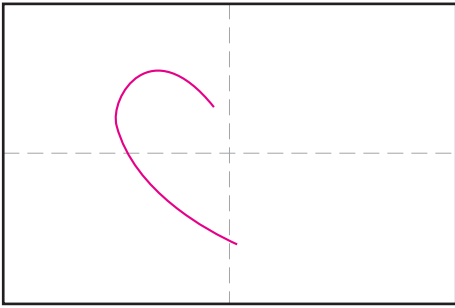

1. Fold to make guide lines. Start with a slightly tilted left side of a heart.

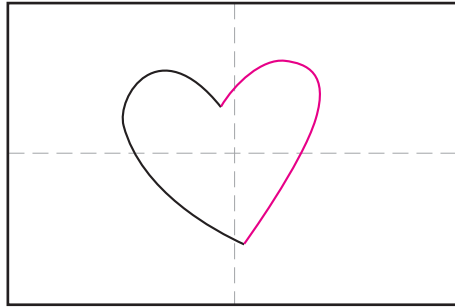

2. Draw the slightly tilted right side of the heart.

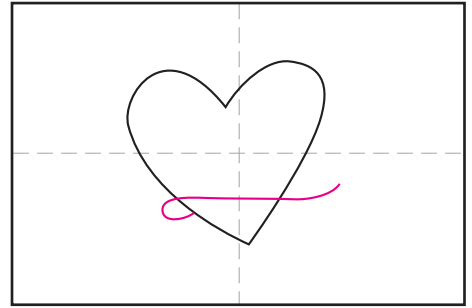

3. Start the bottom line of the ribbon.

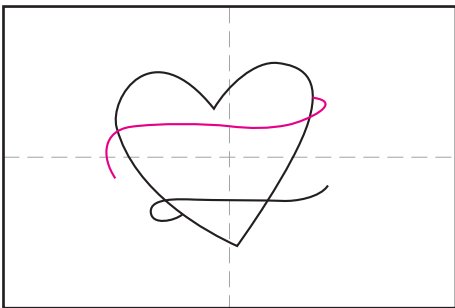

4. Draw the top line of the ribbon.

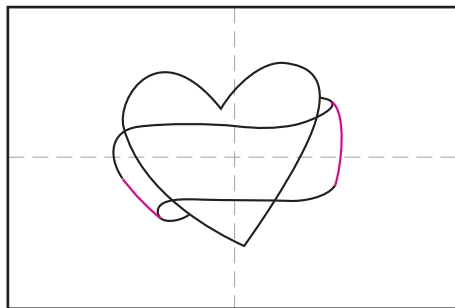

5. Connect the lines to draw the sides of the ribbon.

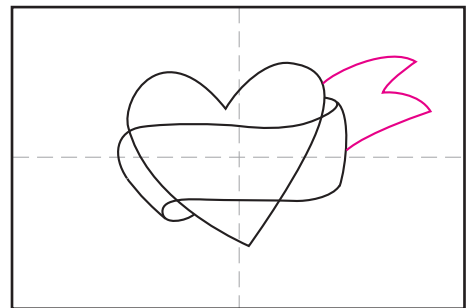

6. Draw the right end of the ribbon.

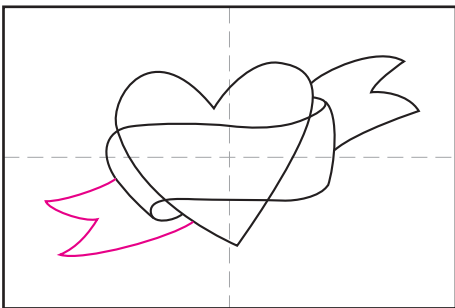

7. Draw the left end of the ribbon.

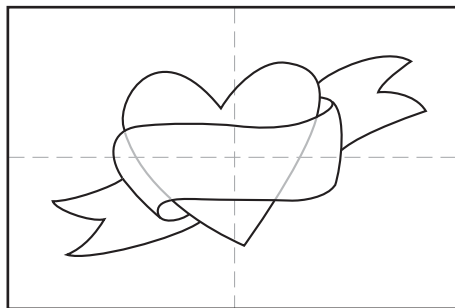

8. Erase the lines inside the front ribbon.

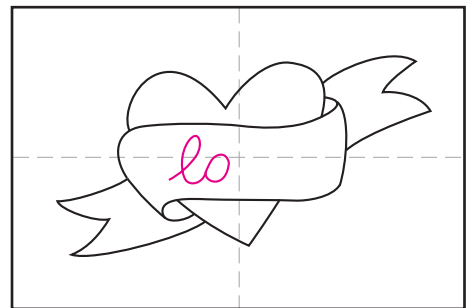

9. Start the lettering with a cursive l - o.

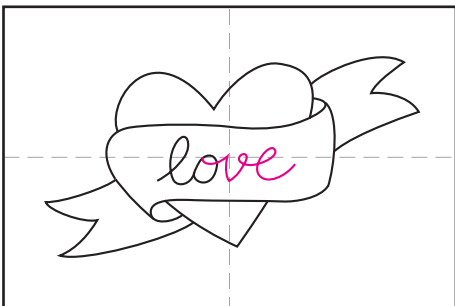

10. Finish with cursive v - e.

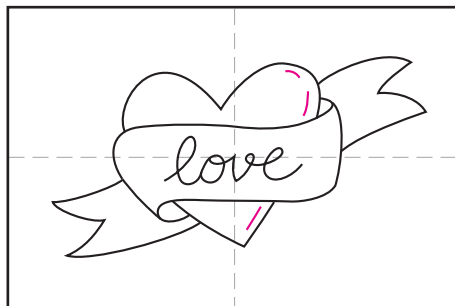

11. Add some lines to indicate a shadow.



12. Trace with a RediSharp black marker and paint with Prang Oval 16 watercolors.

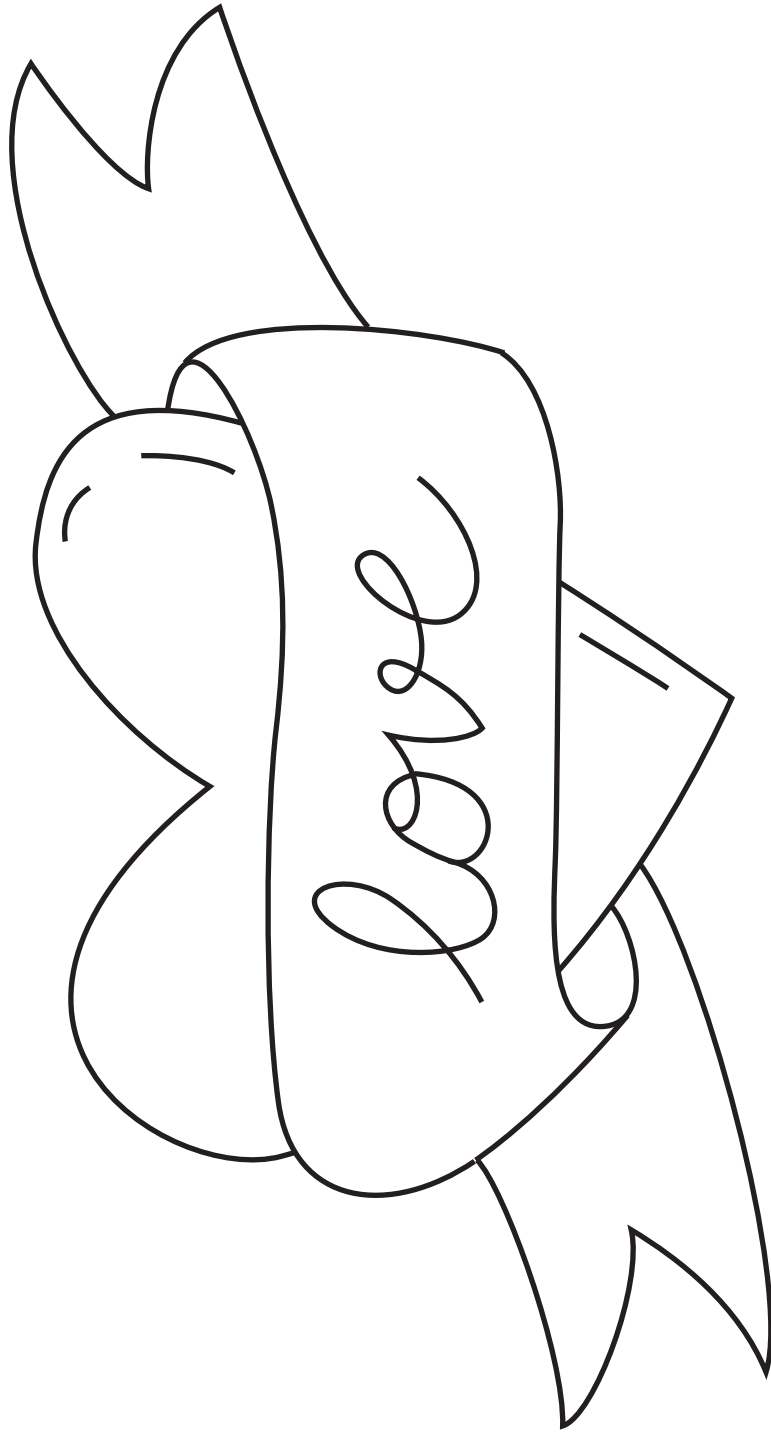

# Heart Hand



# Heart Hand Tutorial

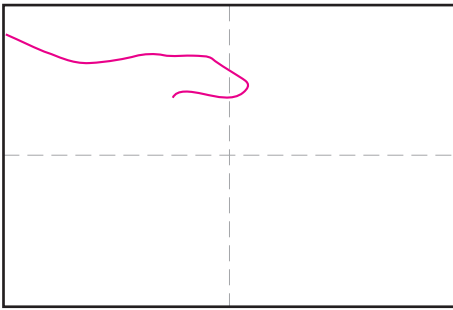

1. Fold to make guide lines. Start the left hand and draw a thumb.

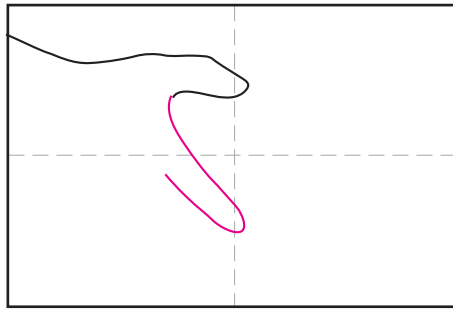

2. Add the index finger.

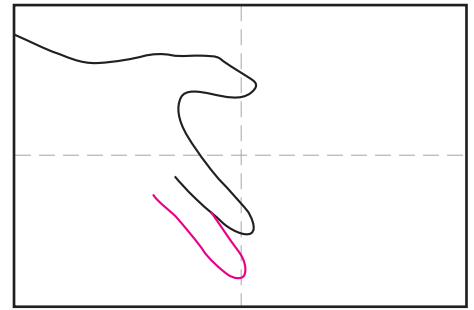

3. Add the middle finger.

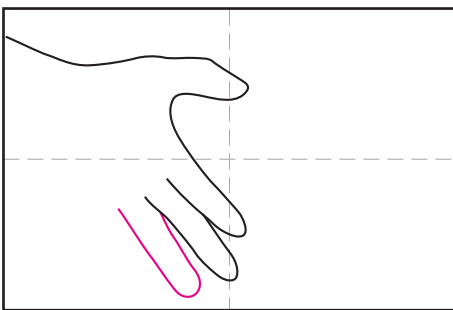

4. Add the fourth finger.

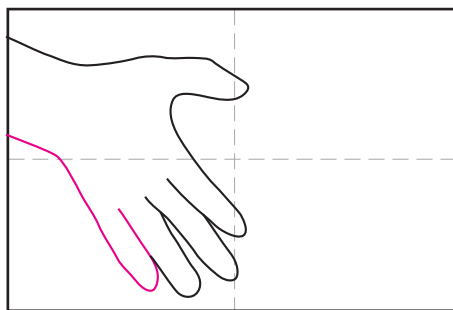

5. Draw the pinkie finger and finish hand.

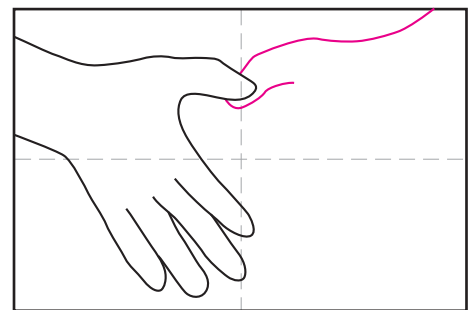

6. Draw the right thumb.

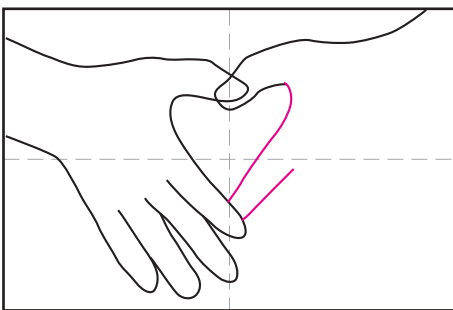

7. Add the right fore finger.

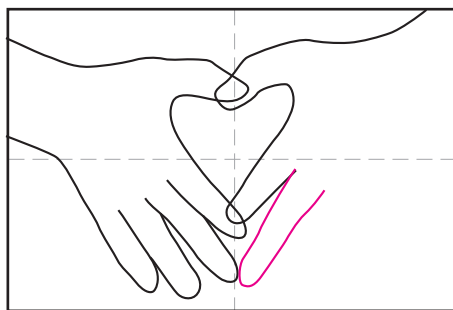

8. Add right middle finger.

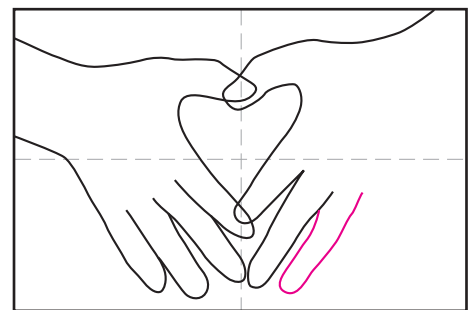

9. Add right fourth finger.

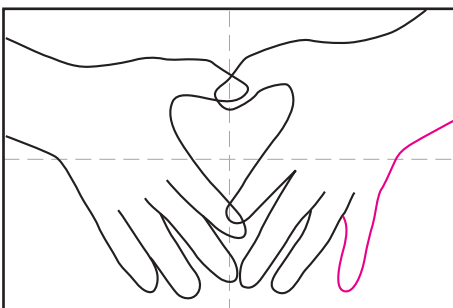

10. Add right pinkie and finish hand.

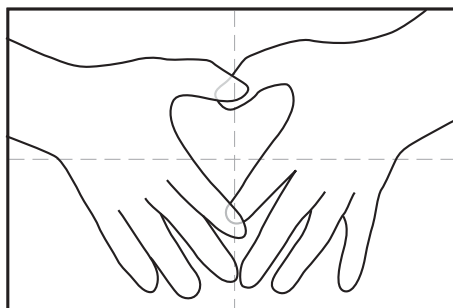

11. Erase any overlapping shapes.



12. Trace with a RediSharp black marker and paint with Prang Oval 16 watercolors.

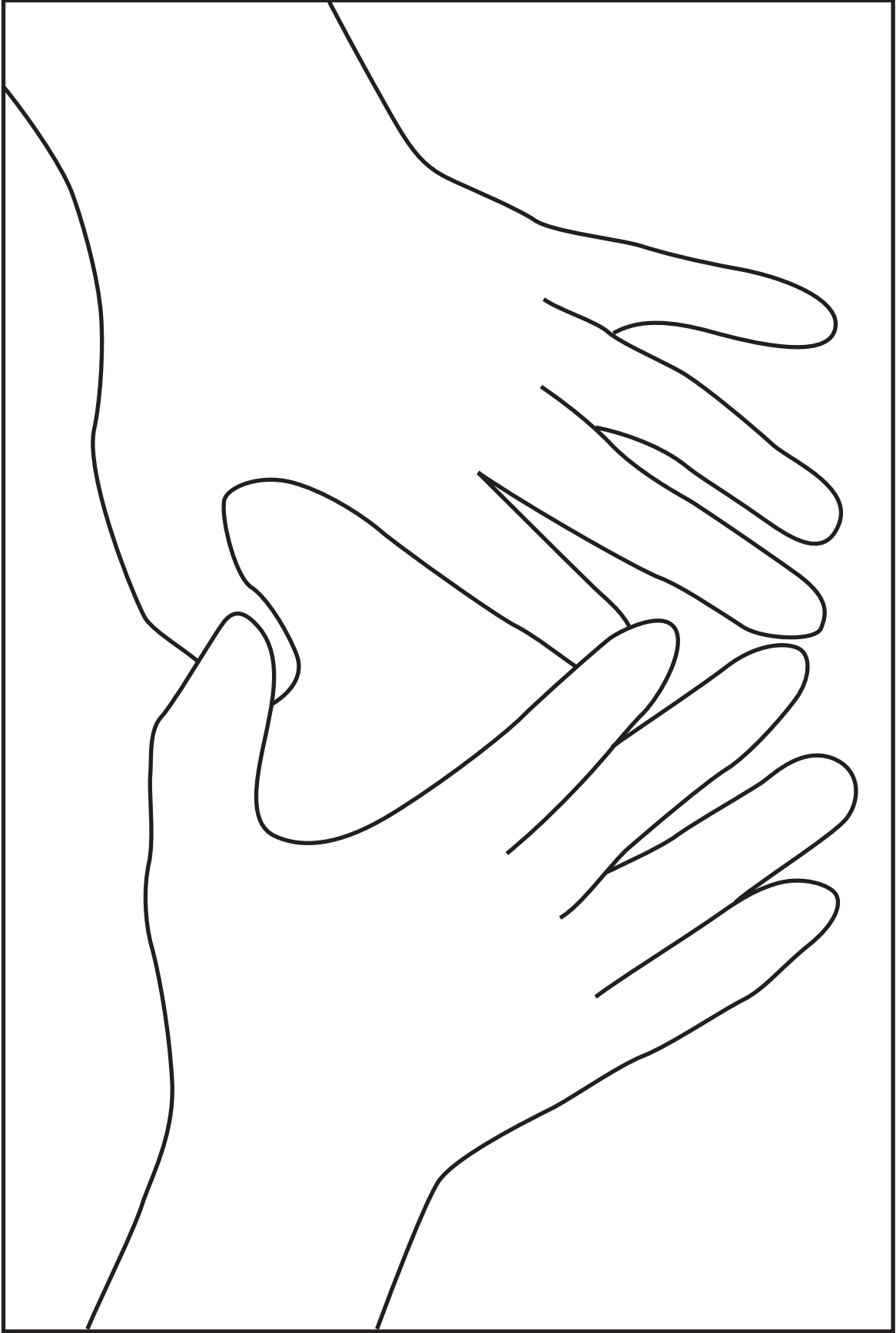

Heart with Wings

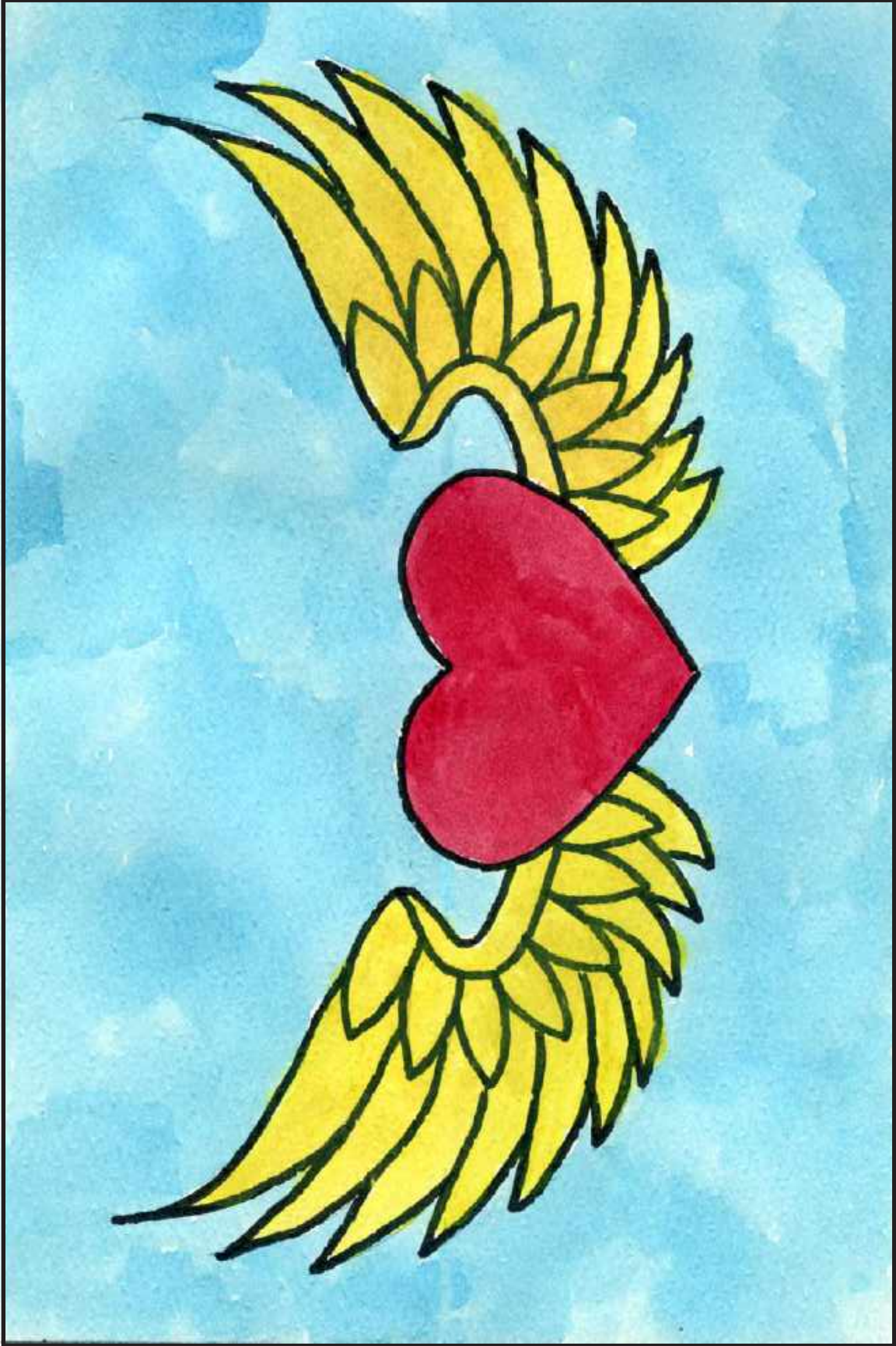

# Heart with Wings Tutorial

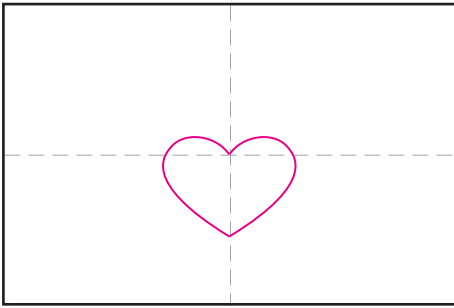

1. Fold to make guide lines. Draw a center heart.

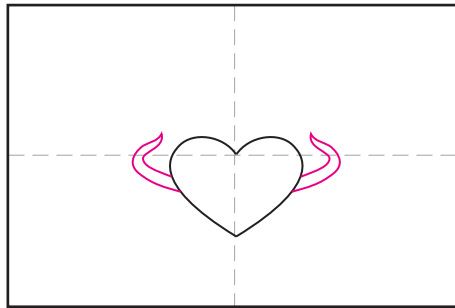

2. Draw two symmetrical horn shapes.

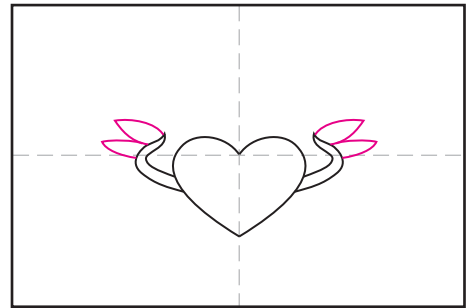

3. To add a row of small symmetrical feathers, start with two at the top.

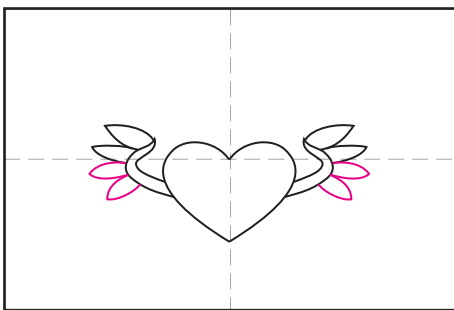

4. Draw two more matching feathers below.

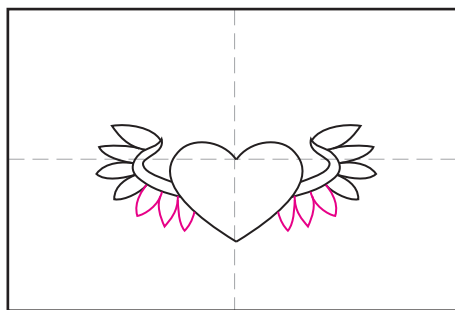

5. Draw three more matching feathers below.

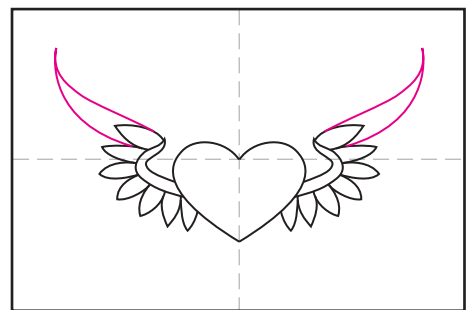

6. Start the row of long feathers with two matching at the top.

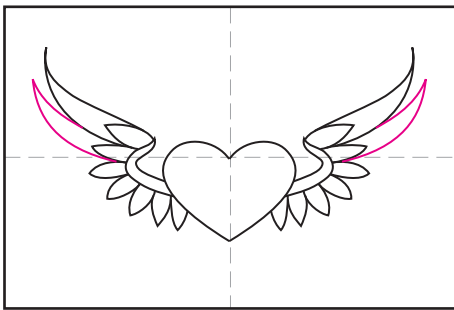

7. Add another long feather below.

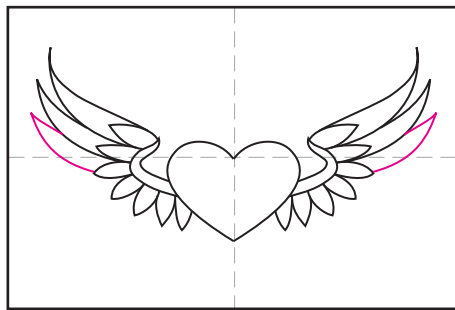

8. Add another long feather below.

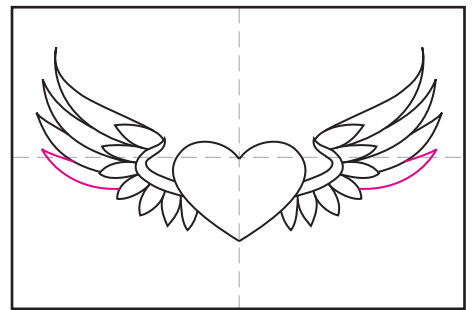

9. Add another long feather below.

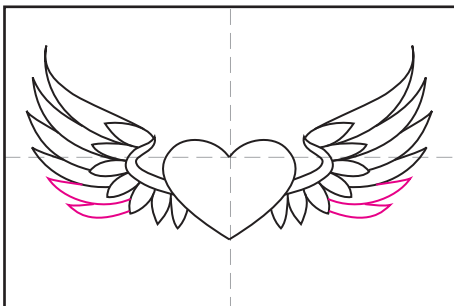

10. Add two more long feathers below.

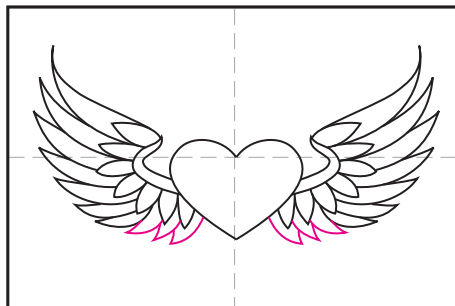

11. Add three feathers below. Congratulations! Symmetrical curved shapes are some of the hardest to draw.



12. Trace with a RediSharp black marker and paint with Prang Oval 16 watercolors.

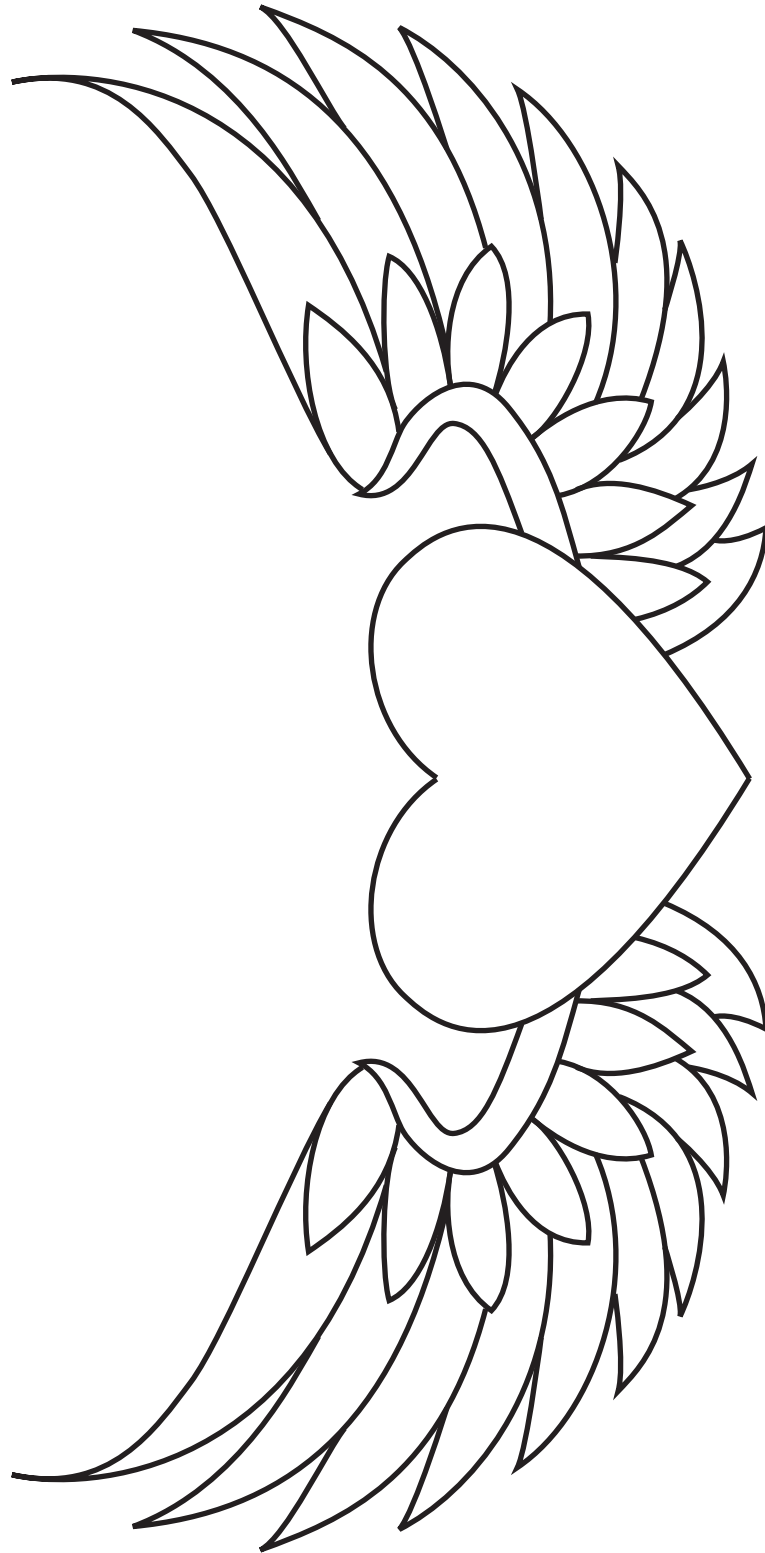

# Hedgehog Valentine



Be my Valentine

# Hedgehog Valentine Tutorial

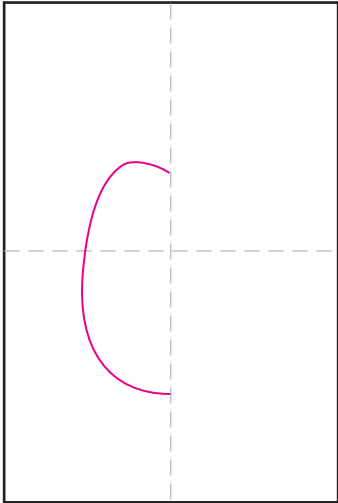

1. Fold to make guide lines. Draw left side of the body.

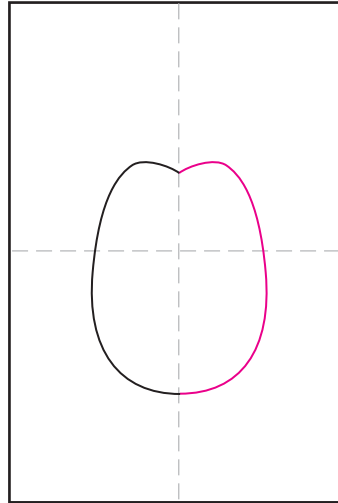

2. Draw a matching right side of the body.

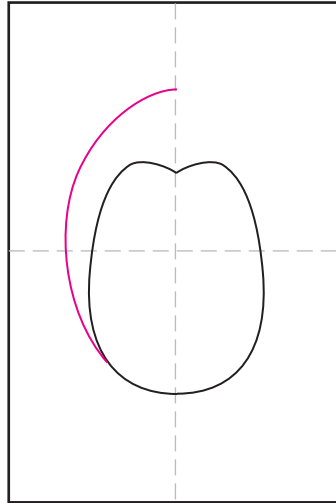

3. Draw left outside body.

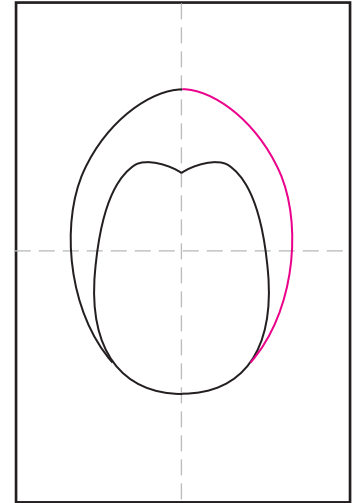

4. Draw the right outside body.

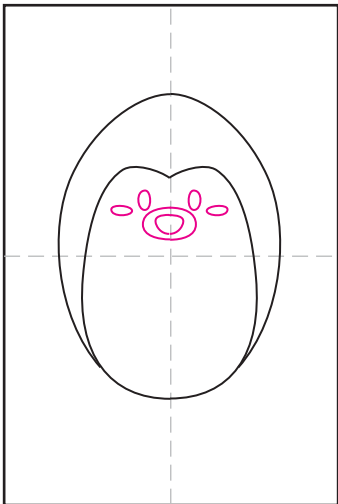

5. Draw the eyes, nose and cheeks.

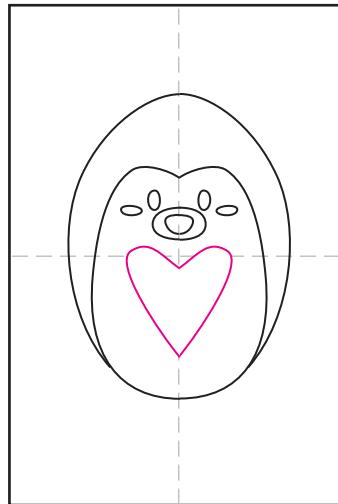

6. Draw a centered heart.

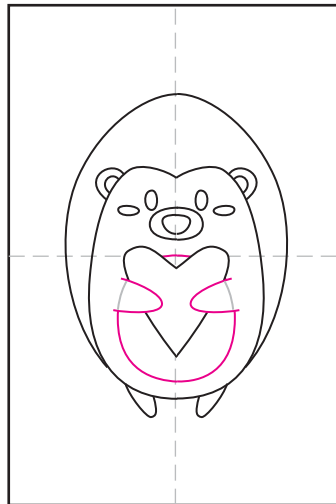

7. Draw the arms and belly around the heart. Erase lines inside the arms.

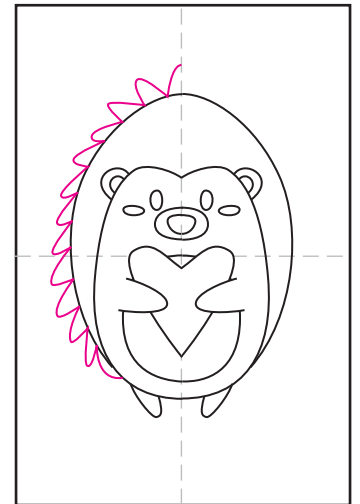

8. Draw the left side spikes.

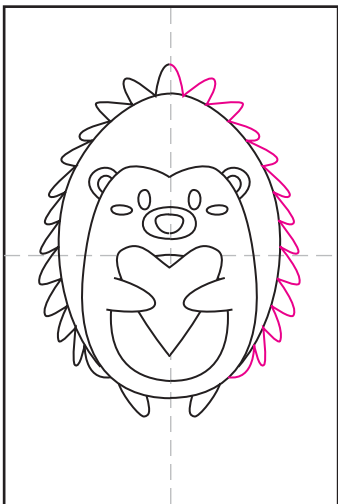

9. Draw the right side spikes.

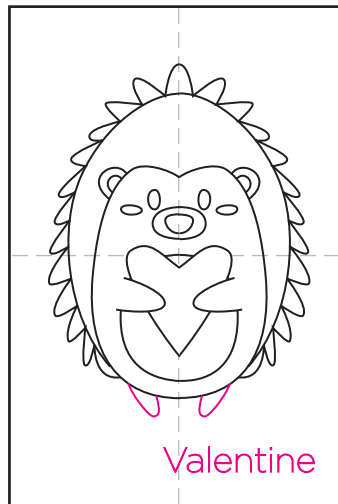

10. Add two feet. Write "Valentine" on the right.

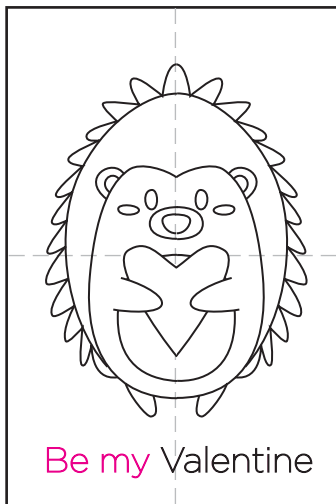

11. Finish with "Be my" on the left. This will help you center the type below the hedgehog.



12. Trace with a RediSharp black marker and paint with Prang Oval 16 watercolors.



Be my Valentine

# I Heart You Burst



# I Heart You Burst Tutorial

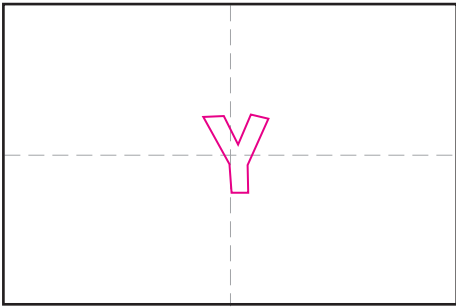

1. Fold to make guide lines. Draw a block letter "Y" in the center of the paper.

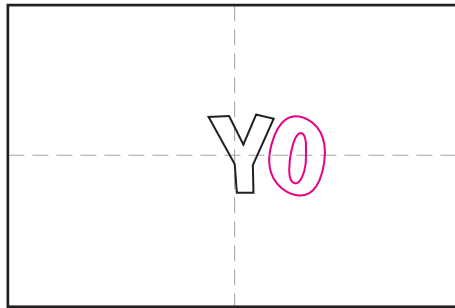

2. Draw a block letter "O" to the right.

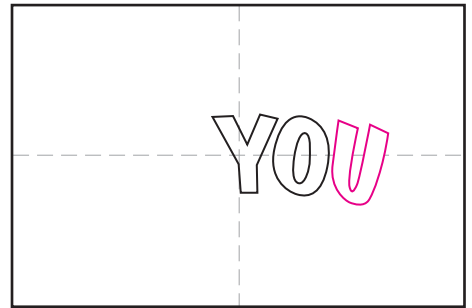

3. Draw a block letter "U" to the right.

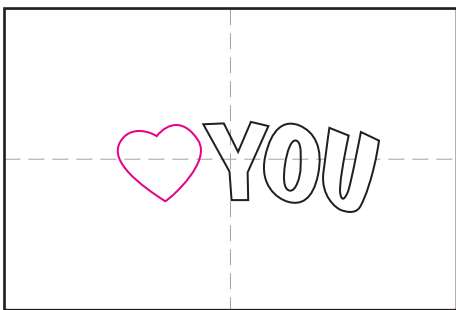

4. Draw a heart to the left.

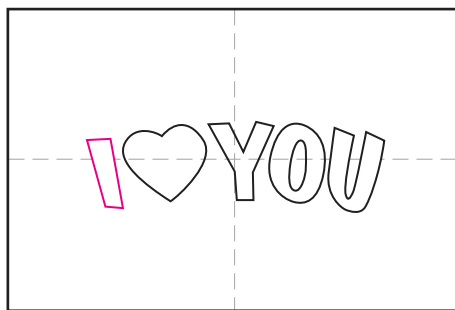

5. Draw a block letter "I" to the right.

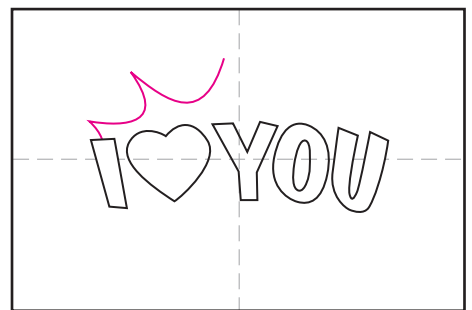

6. Start the burst.

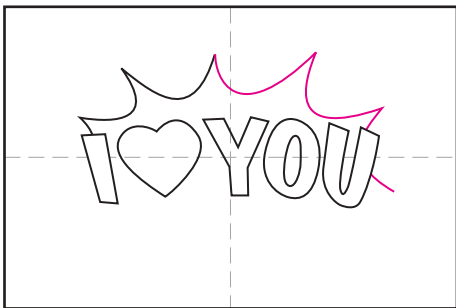

7. Continue the burst (going behind the letters).

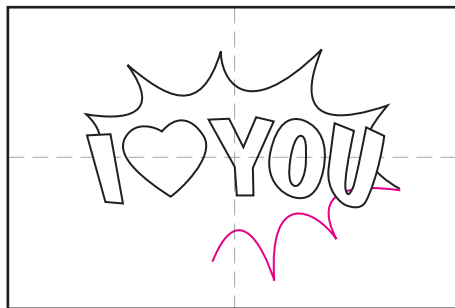

8. Continue the burst on the bottom.

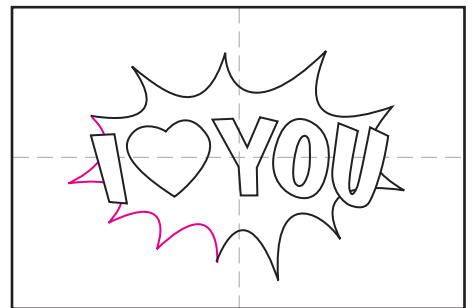

9. Finish the burst.

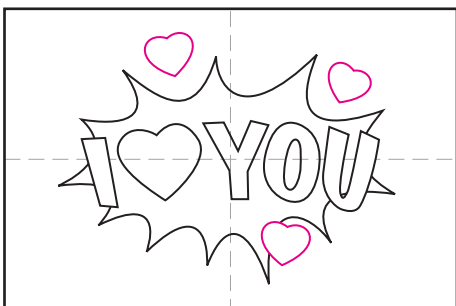

10. Draw three large hearts.

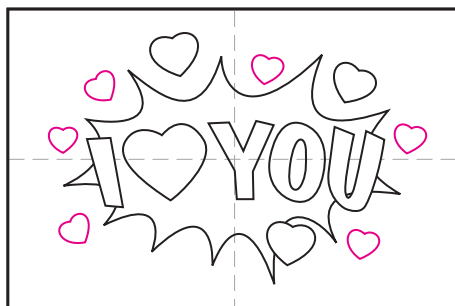

11. Add smaller hearts all around.



12. Trace with a RediSharp black marker and paint with Prang Oval 16 watercolors.

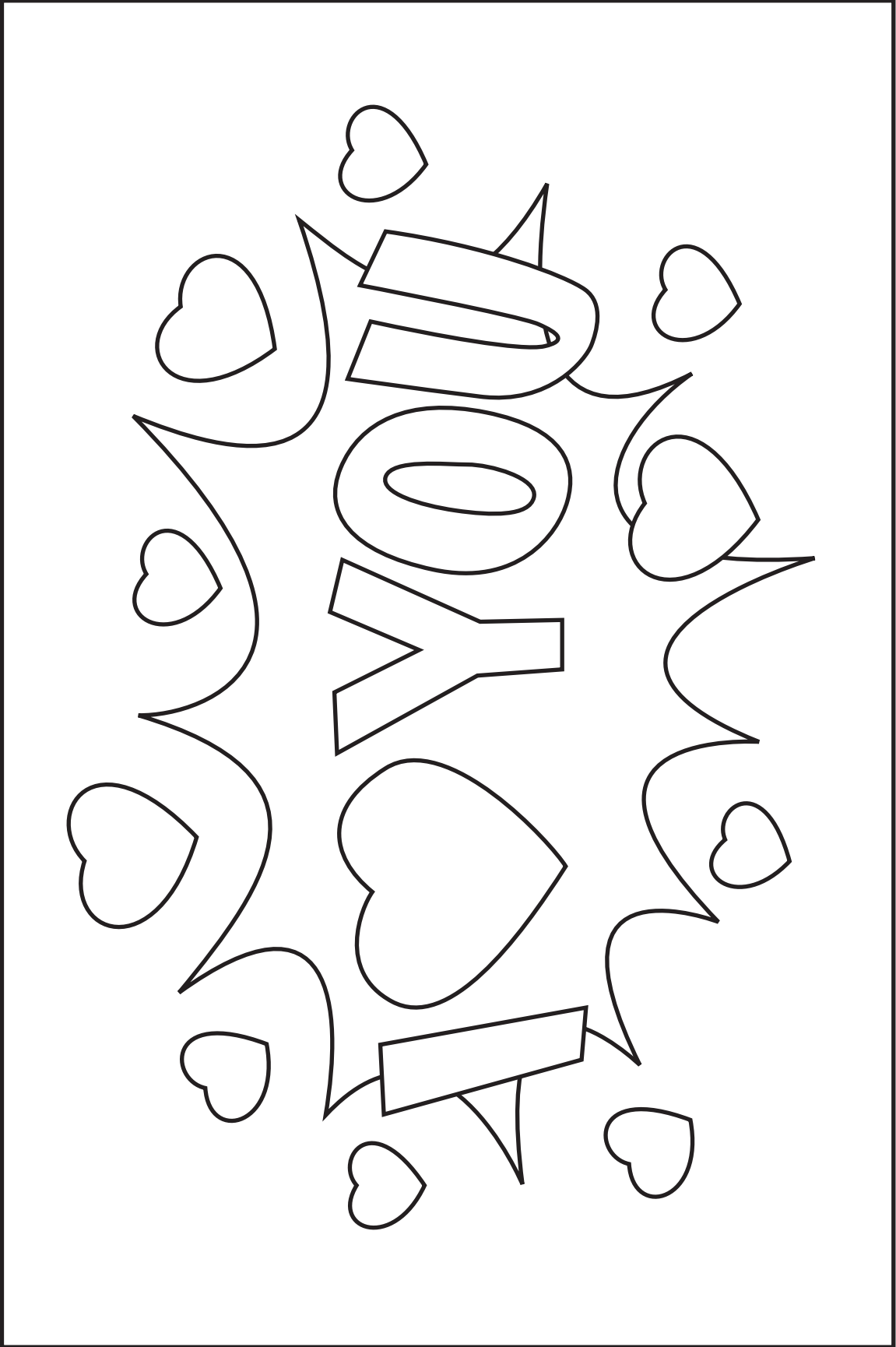

# "I Love You" Bear

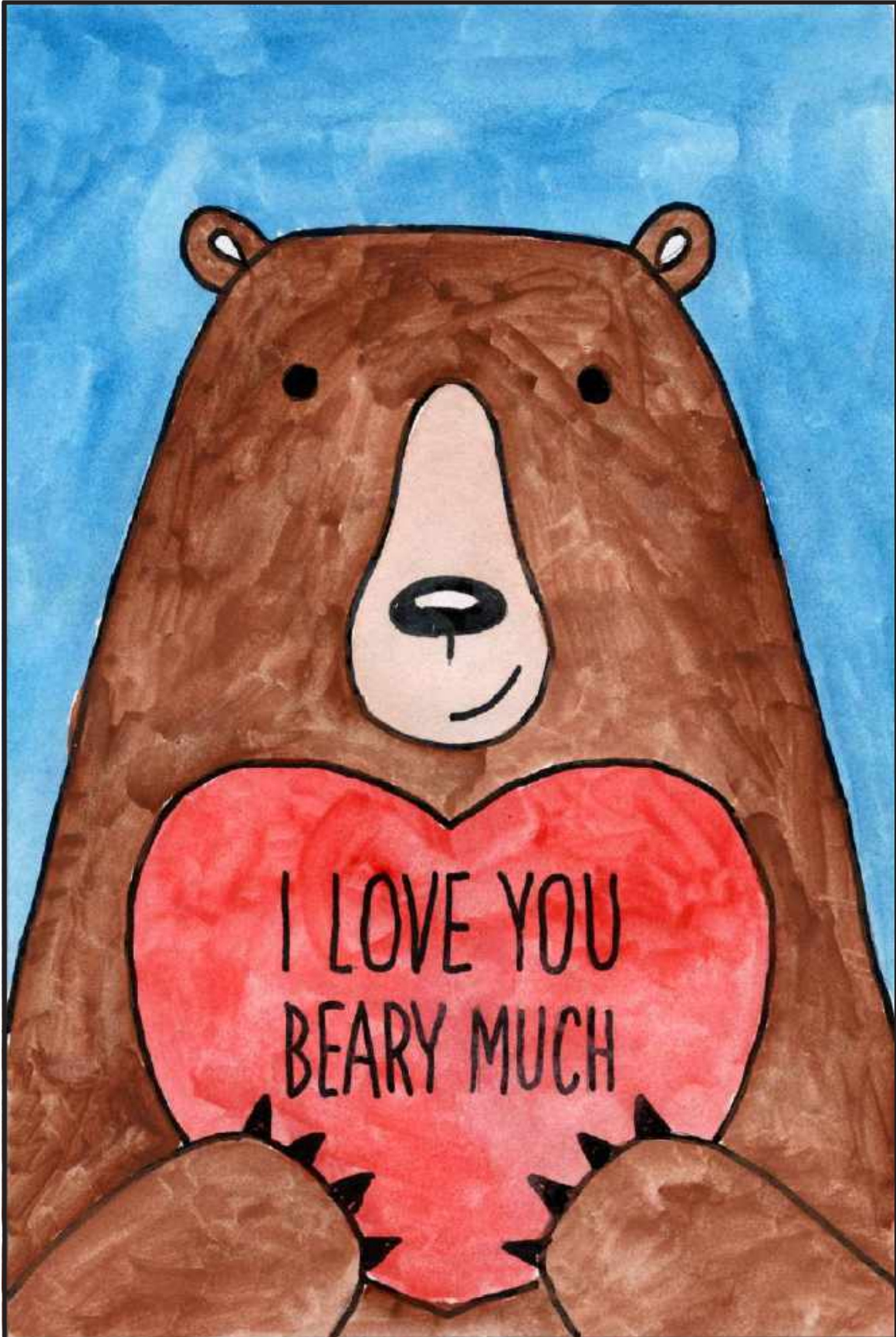

# "I Love You" Bear Tutorial

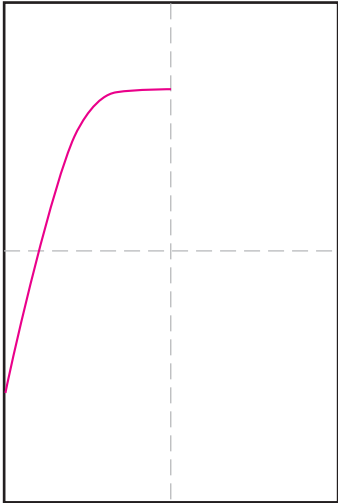

1. Fold to make guide lines. Draw left side of the body.

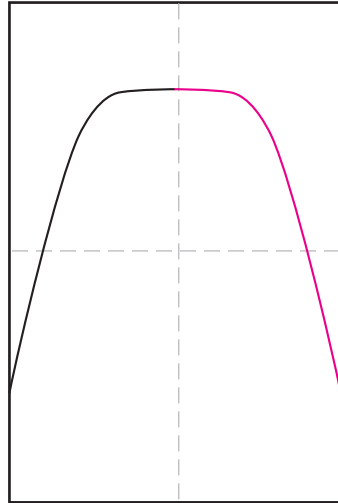

2. Draw a matching right side of the body.

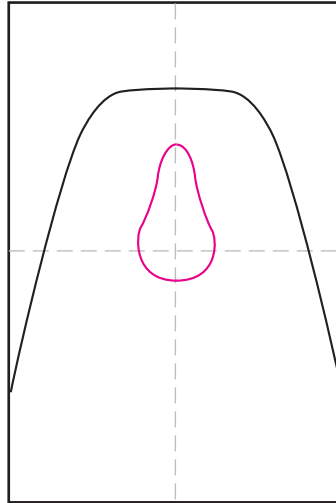

3. Draw the muzzle.

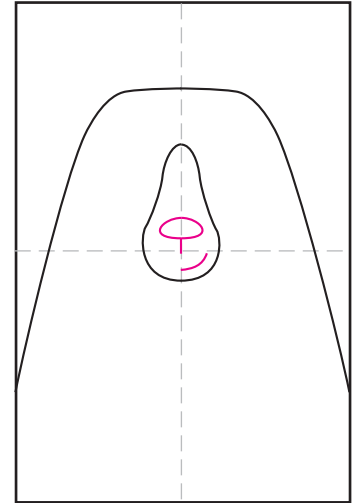

4. Draw a nose and mouth.

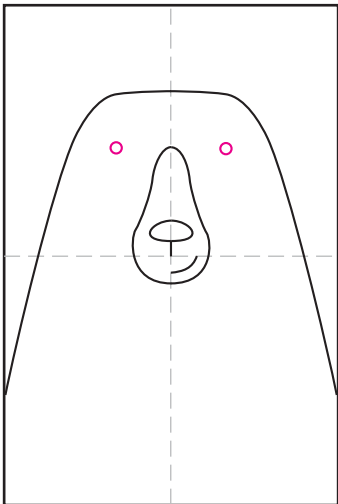

5. Draw two eyes.

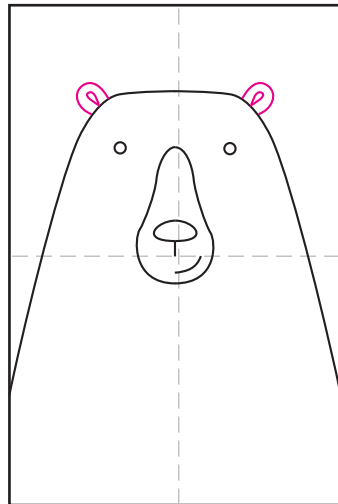

6. Draw two ears.

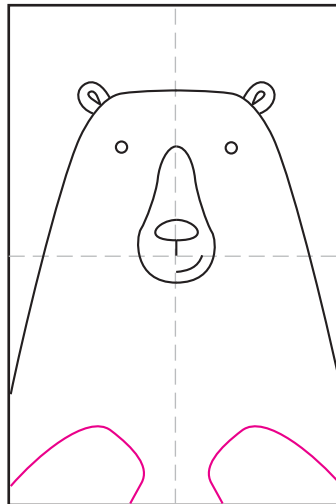

7. Draw two paws.

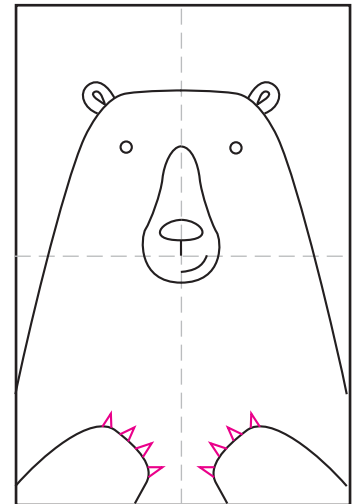

8. Add claws.

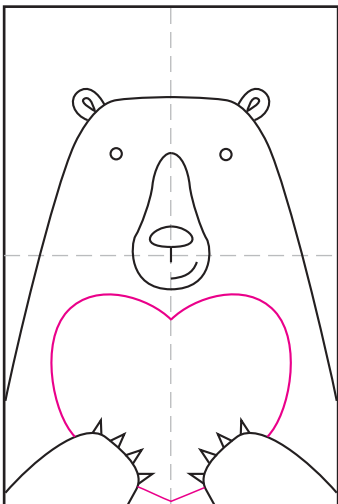

9. Draw a heart behind the paws.



10. Write "I LOVE YOU"

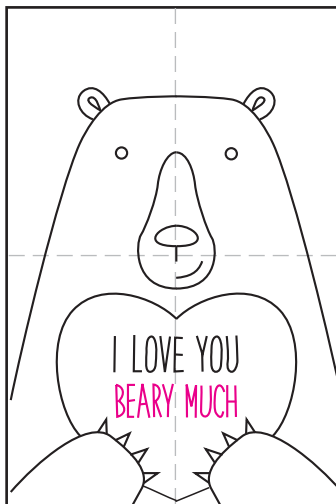

11. Add "BEARY MUCH" below.

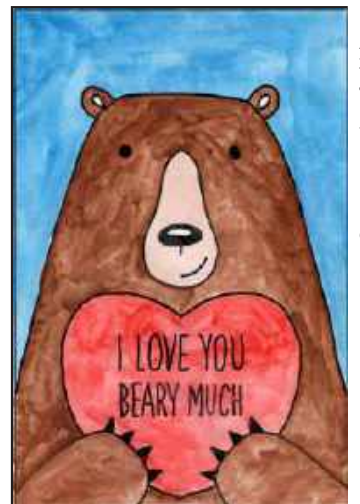

12. Trace with a RediSharp black marker and paint with Prang Oval 16 watercolors.

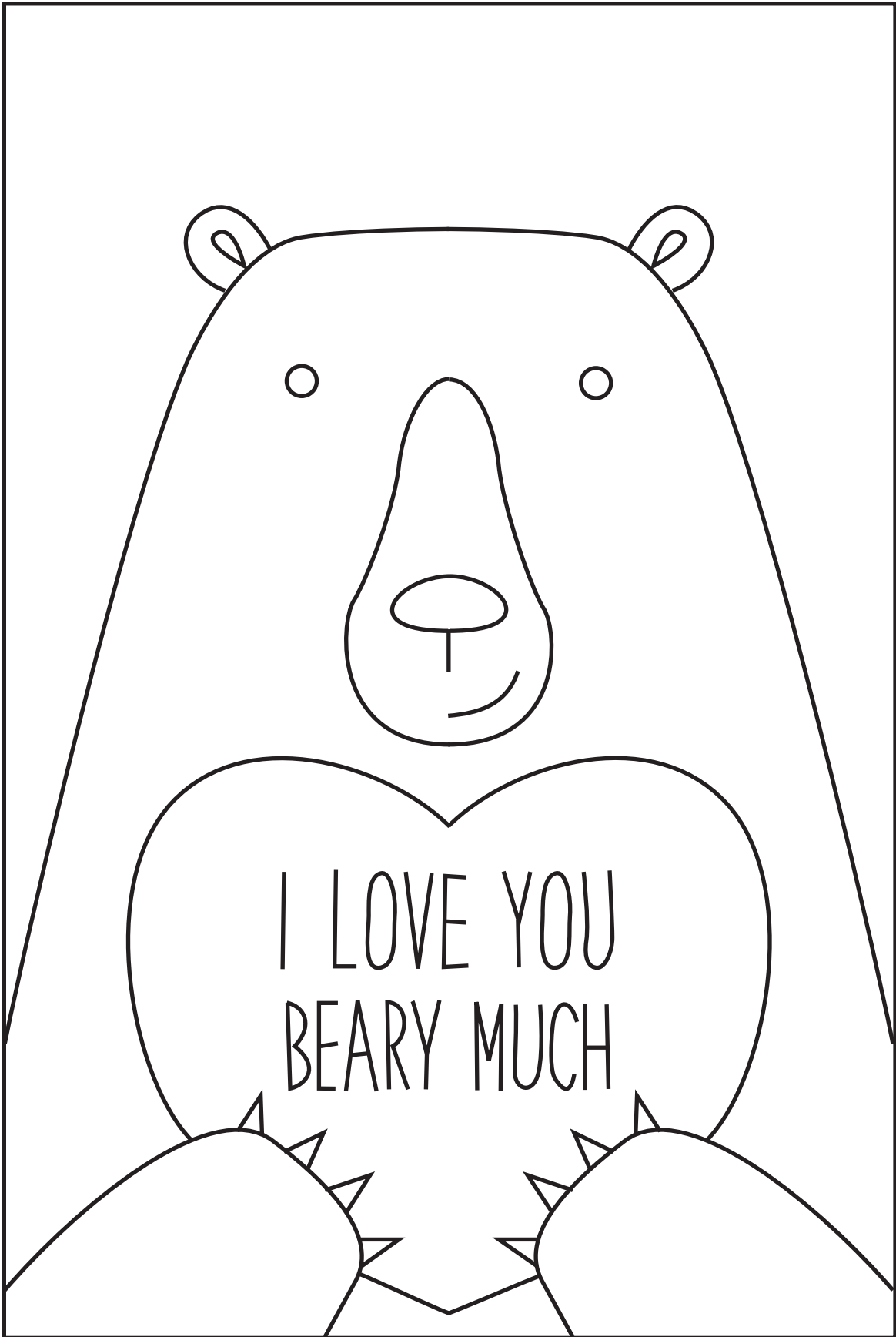

# "I Love You" Cat



# "I Love You" Cat Tutorial

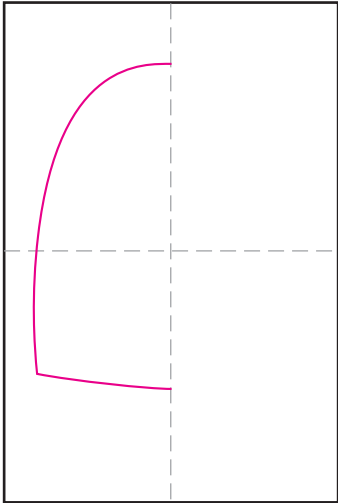

1. Fold to make guide lines. Draw left side of the body.

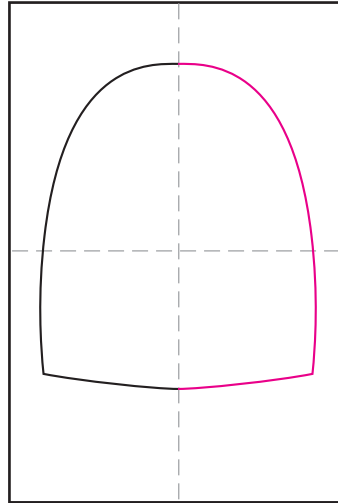

2. Draw a matching right side of the body.

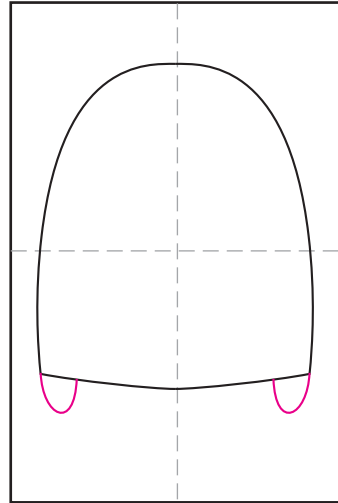

3. Draw two feet.

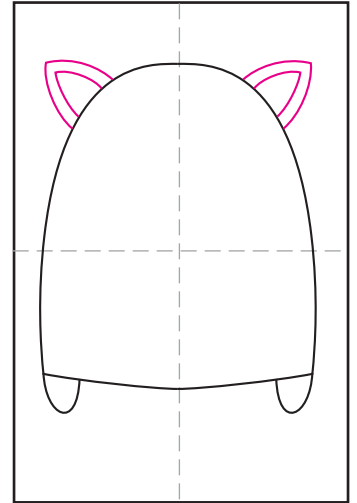

4. Draw two ears.

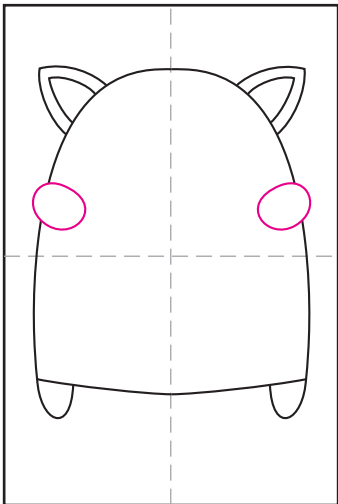

5. Draw two paws.

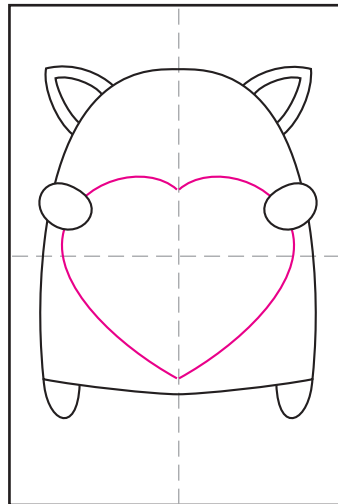

6. Draw a heart.

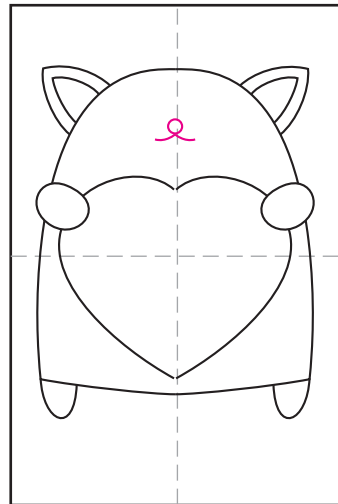

7. Draw nose and mouth.

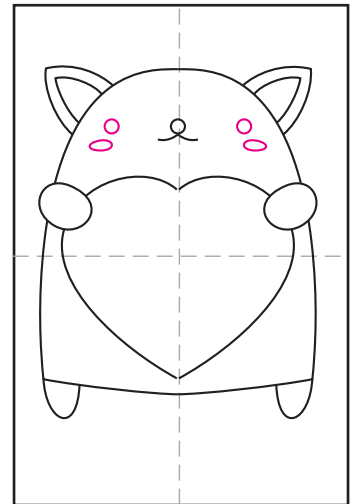

8. Add two eyes.

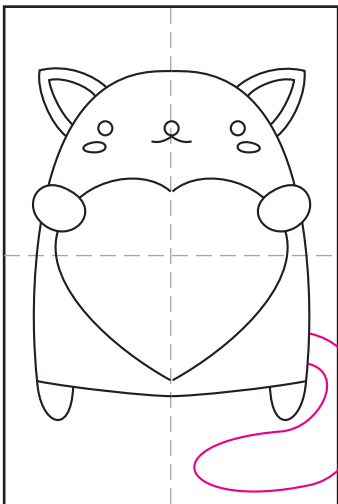

9. Add a large tail.

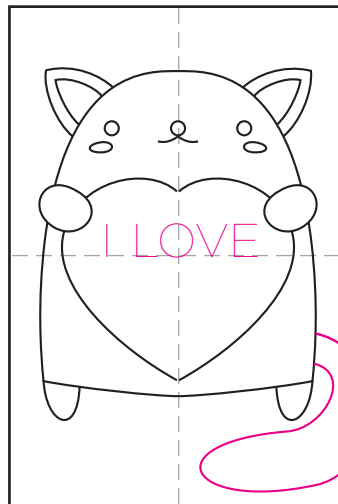

10. Write "I LOVE" on the line.

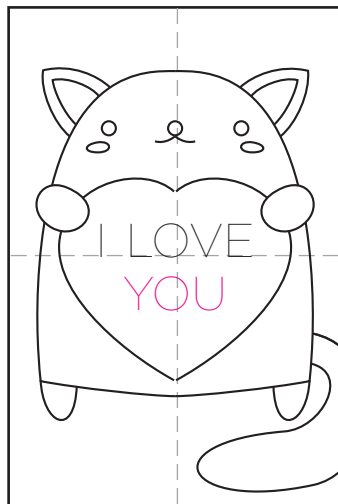

11. Add "YOU" below.



12. Trace with a RediSharp black marker and paint with Prang Oval 16 watercolors.

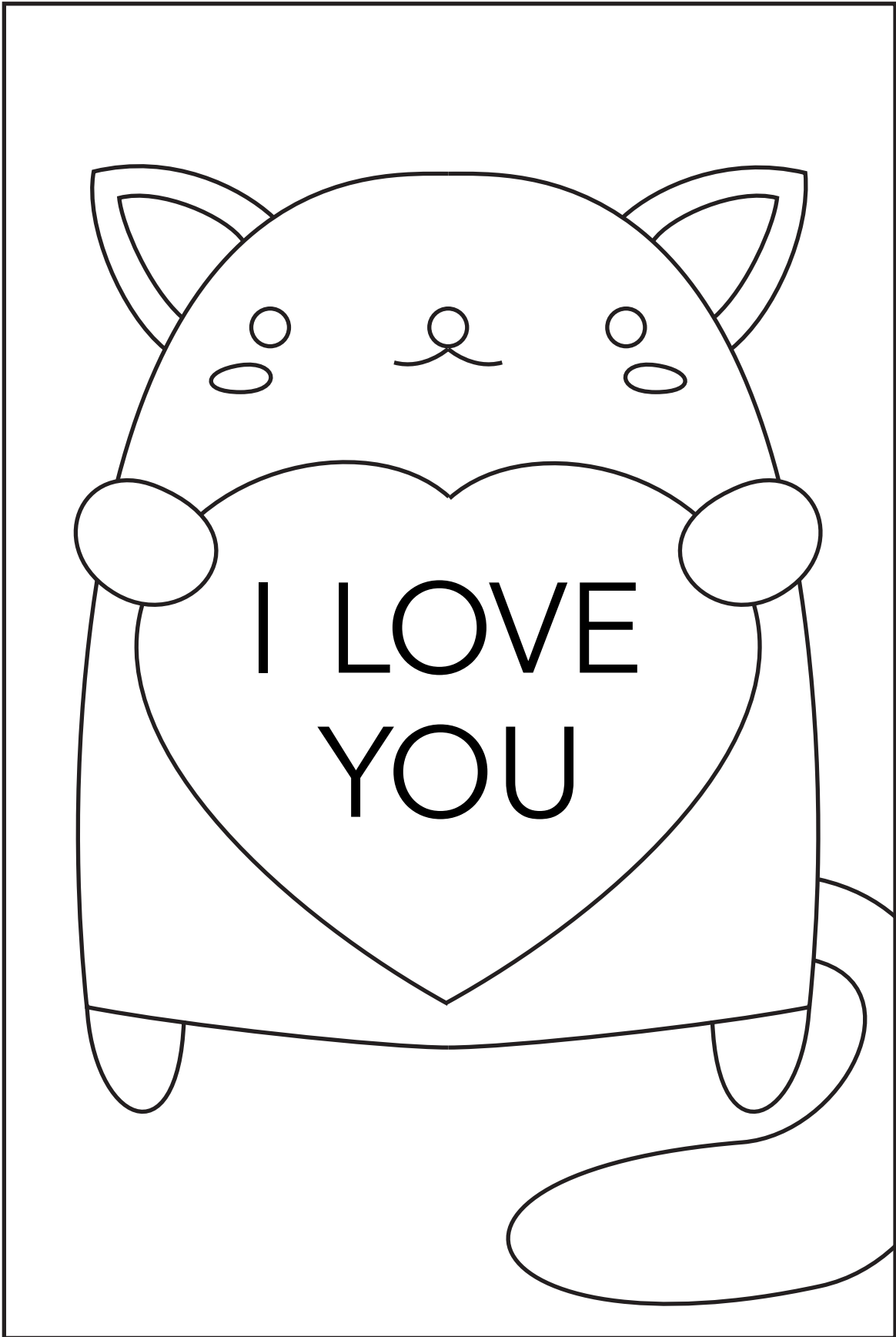

# Labrador Valentine



# Labrador Valentine Tutorial

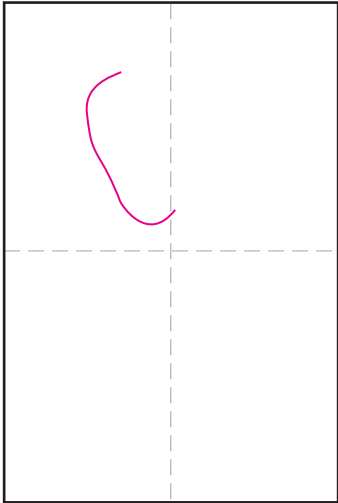

1. Fold to make guide lines. Draw the left side of the head at an angle.

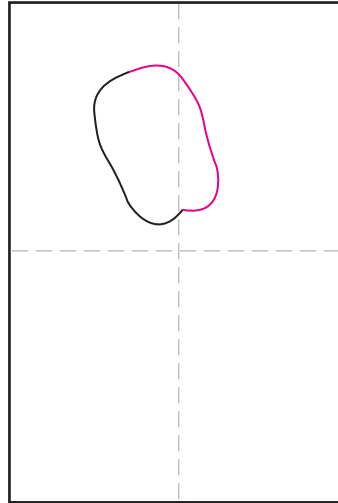

2. Draw the right side.

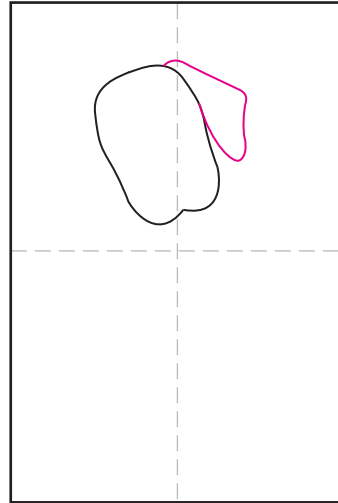

3. Draw the right ear.

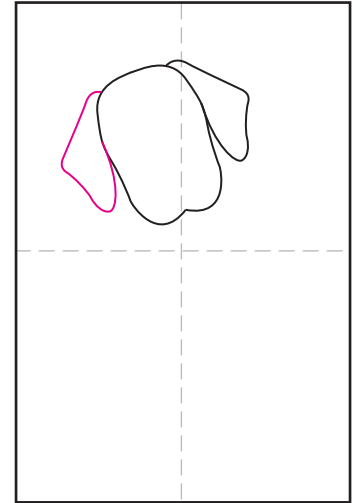

4. Draw the left ear.

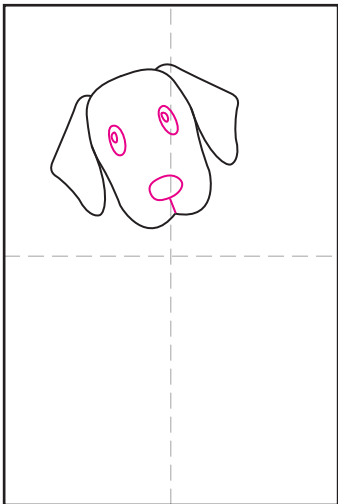

5. Add the eyes and nose.

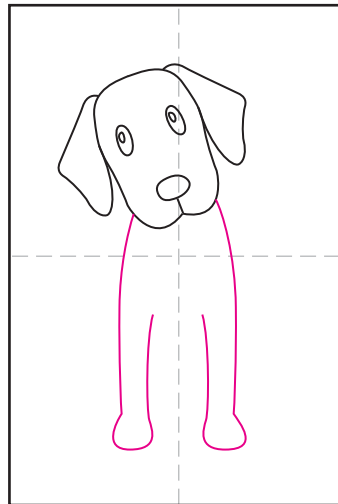

6. Draw two symmetrical front legs.

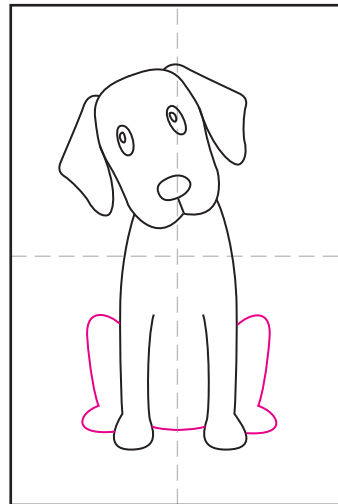

7. Draw two hind legs.

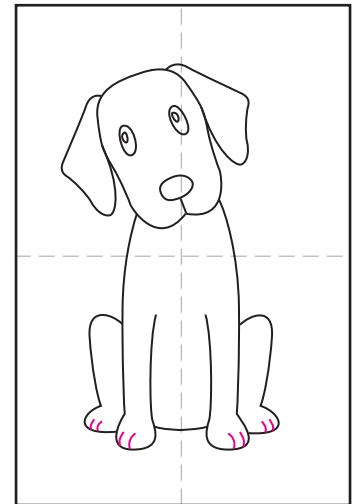

8. Add toenails on the feet.

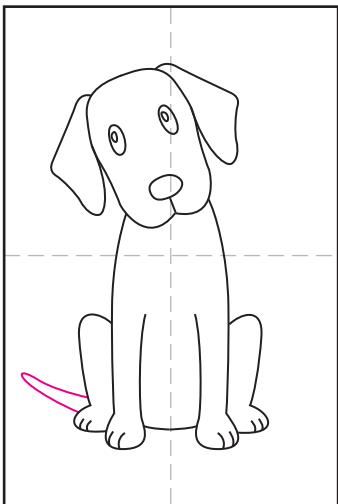

9. Draw a tail.

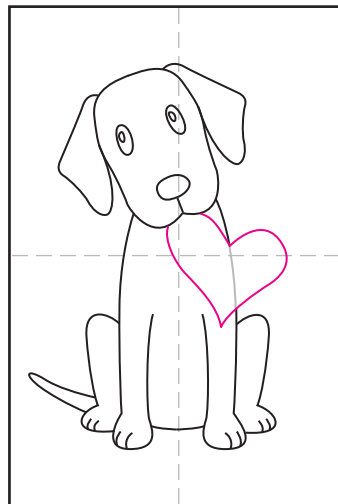

10. Draw a heart in his mouth. Erase any lines inside.

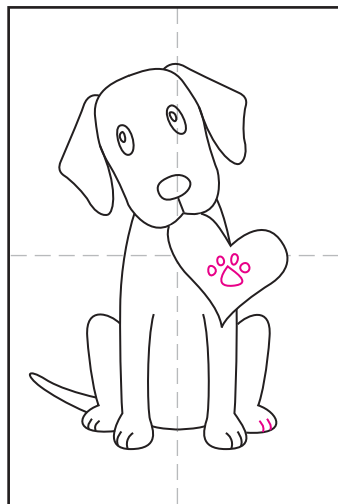

11. Draw a paw print inside.



12. Trace with a RediSharp black marker and paint with Prang Oval 16 watercolors.

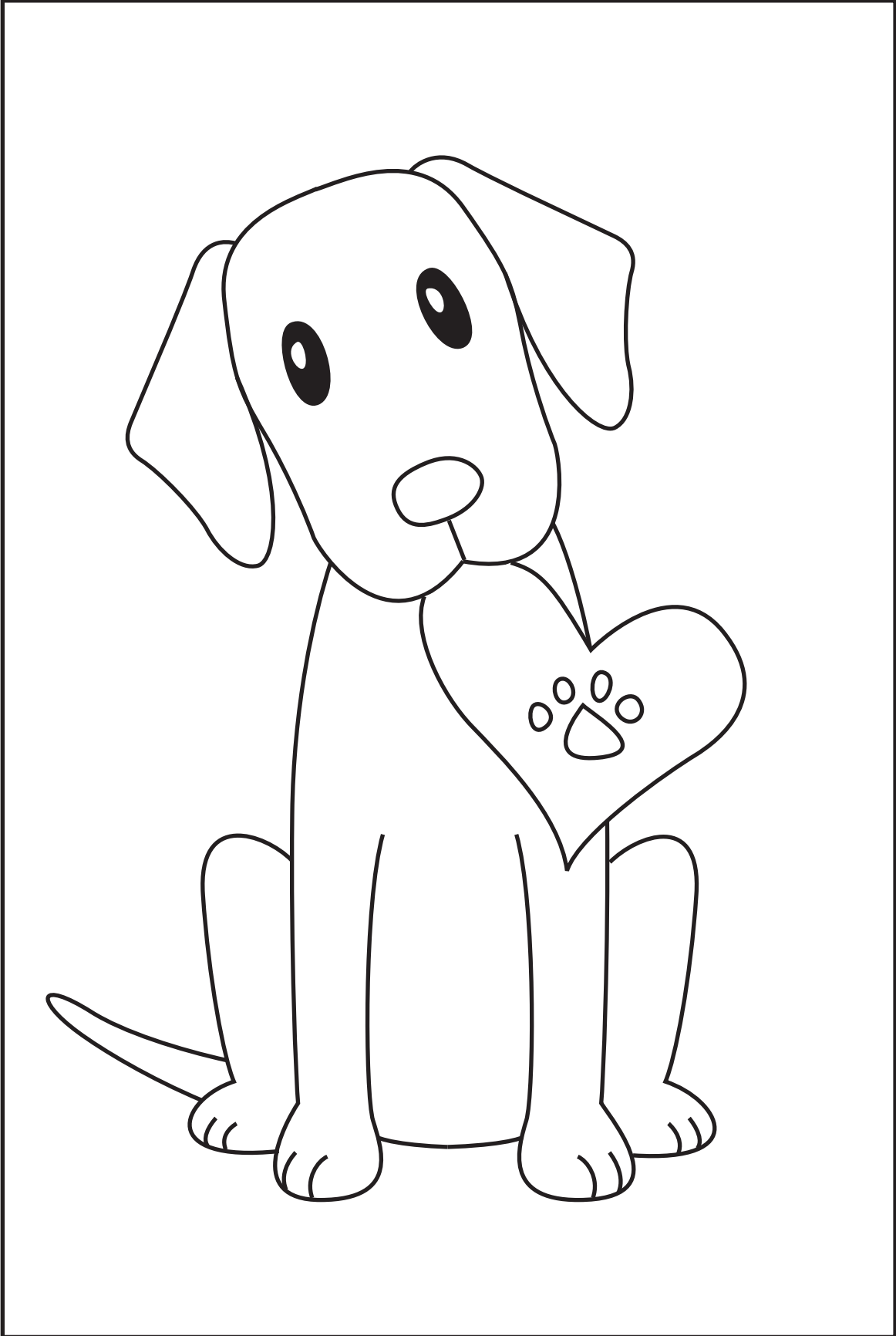

“Llove You Llots!”

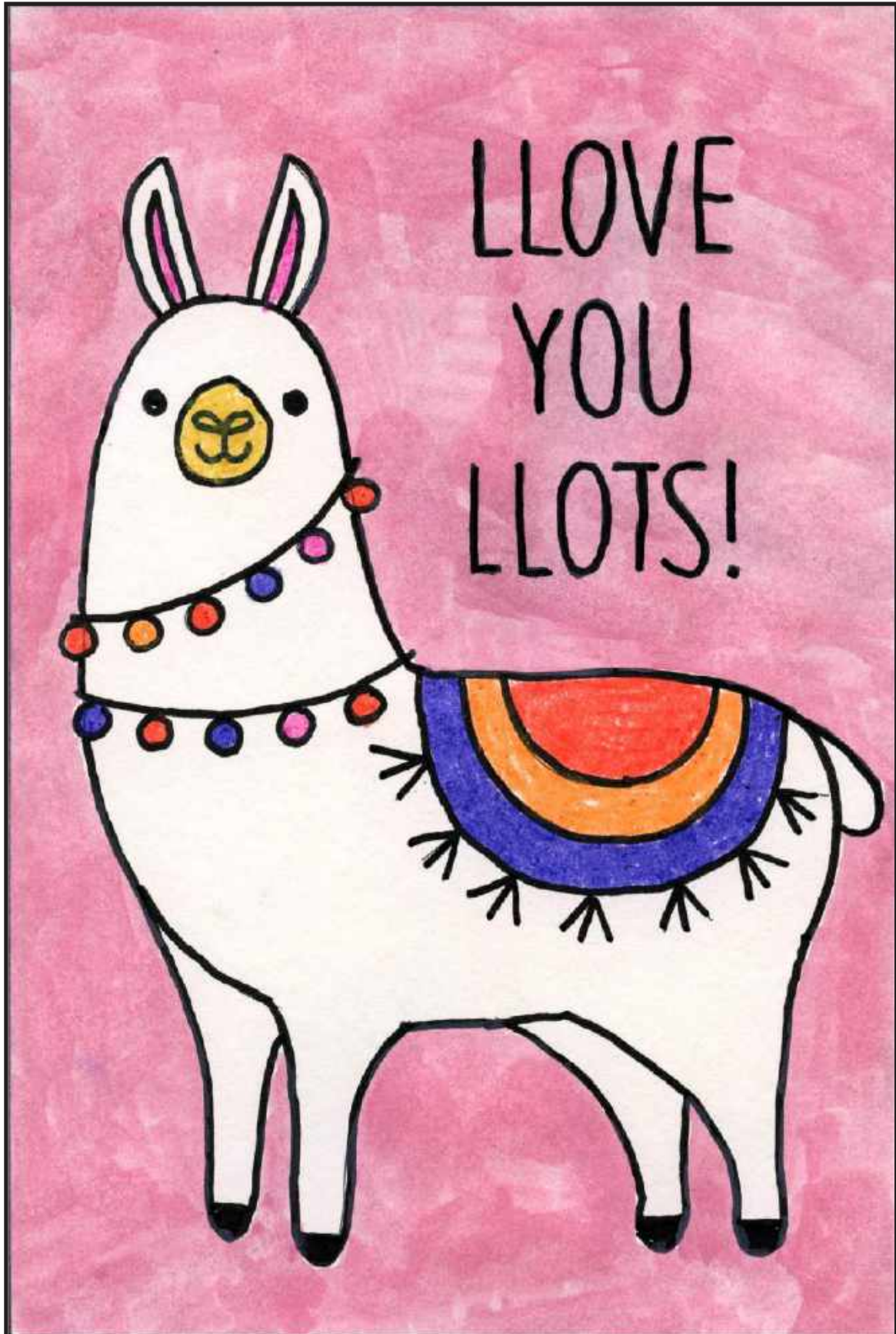

# “Love You Llots” Tutorial

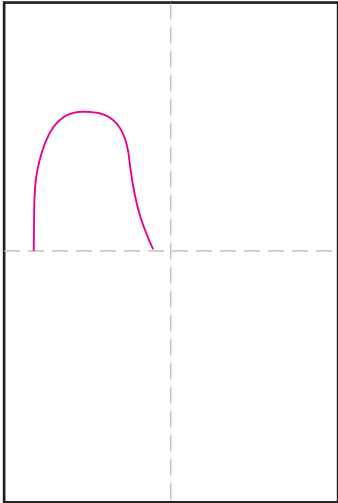

1. Fold to make guide lines. Start the head part of the body.

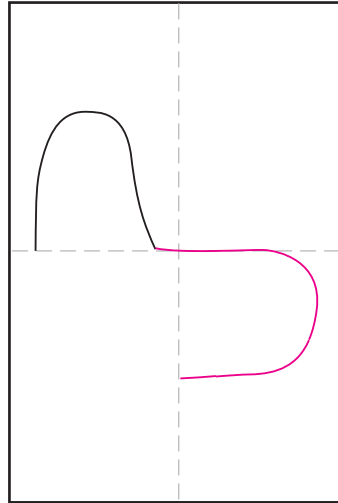

2. Continue with the rear part of the body.

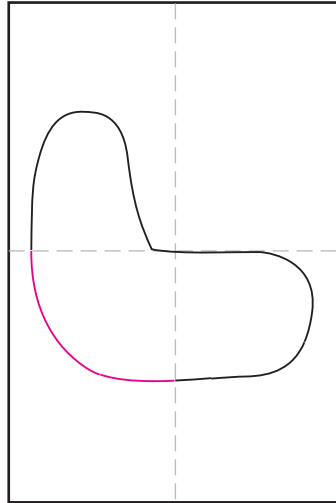

3. Finish with the chest of the body.

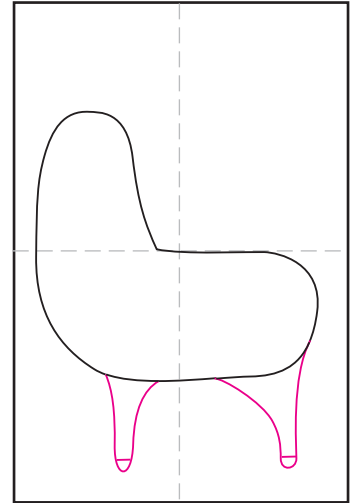

4. Add two legs on one side.

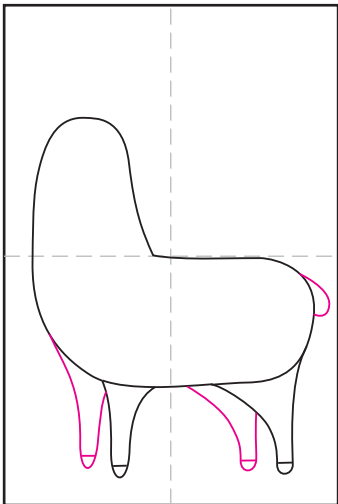

5. Add two other legs on the other side.

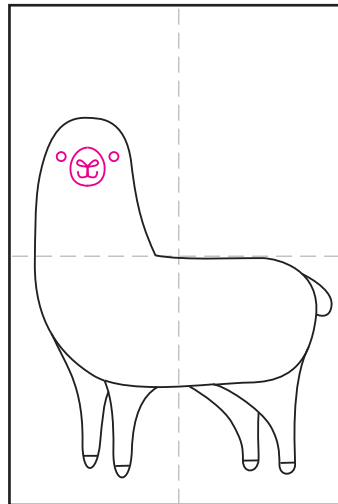

6. Draw the nose, mouth and eyes.

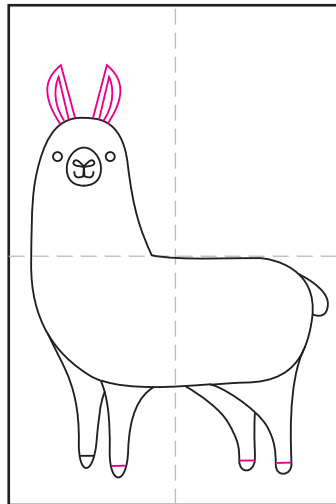

7. Draw two ears.

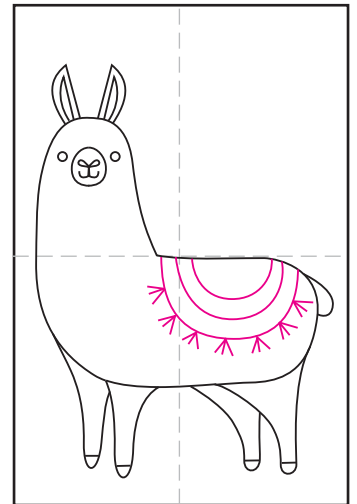

8. Draw a fancy blanket.

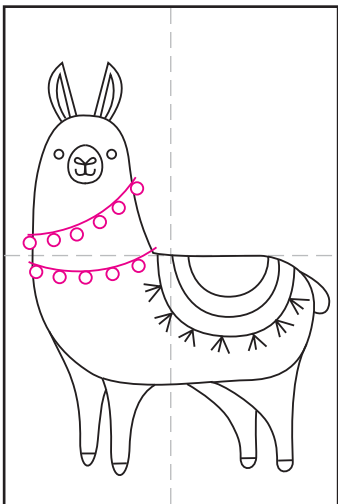

9. Add fancy collar with balls.

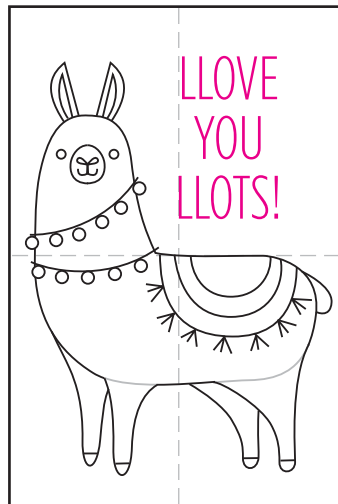

10. Erase inside leg lines. Write “LLOVE YOU LLOTS!” above the llama.

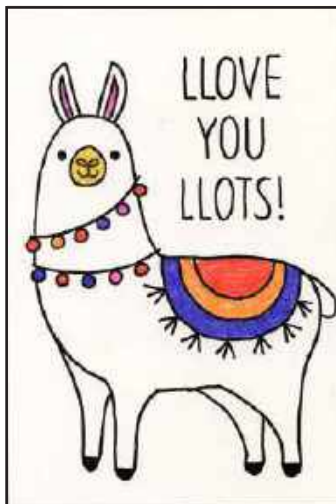

11. Trace with a RediSharp black marker. Color small shapes with Prang crayons.

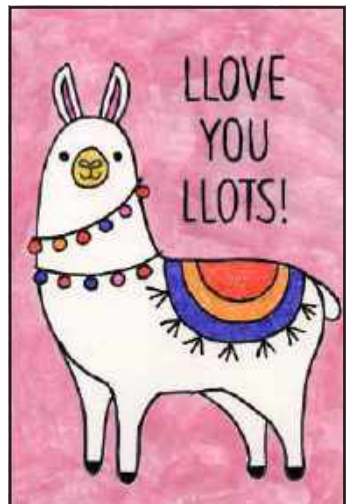

12. Paint background with Prang Oval 16 watercolors. When dry, trace drawing again for definition.

LLOVE  
YOU  
LLOTS!

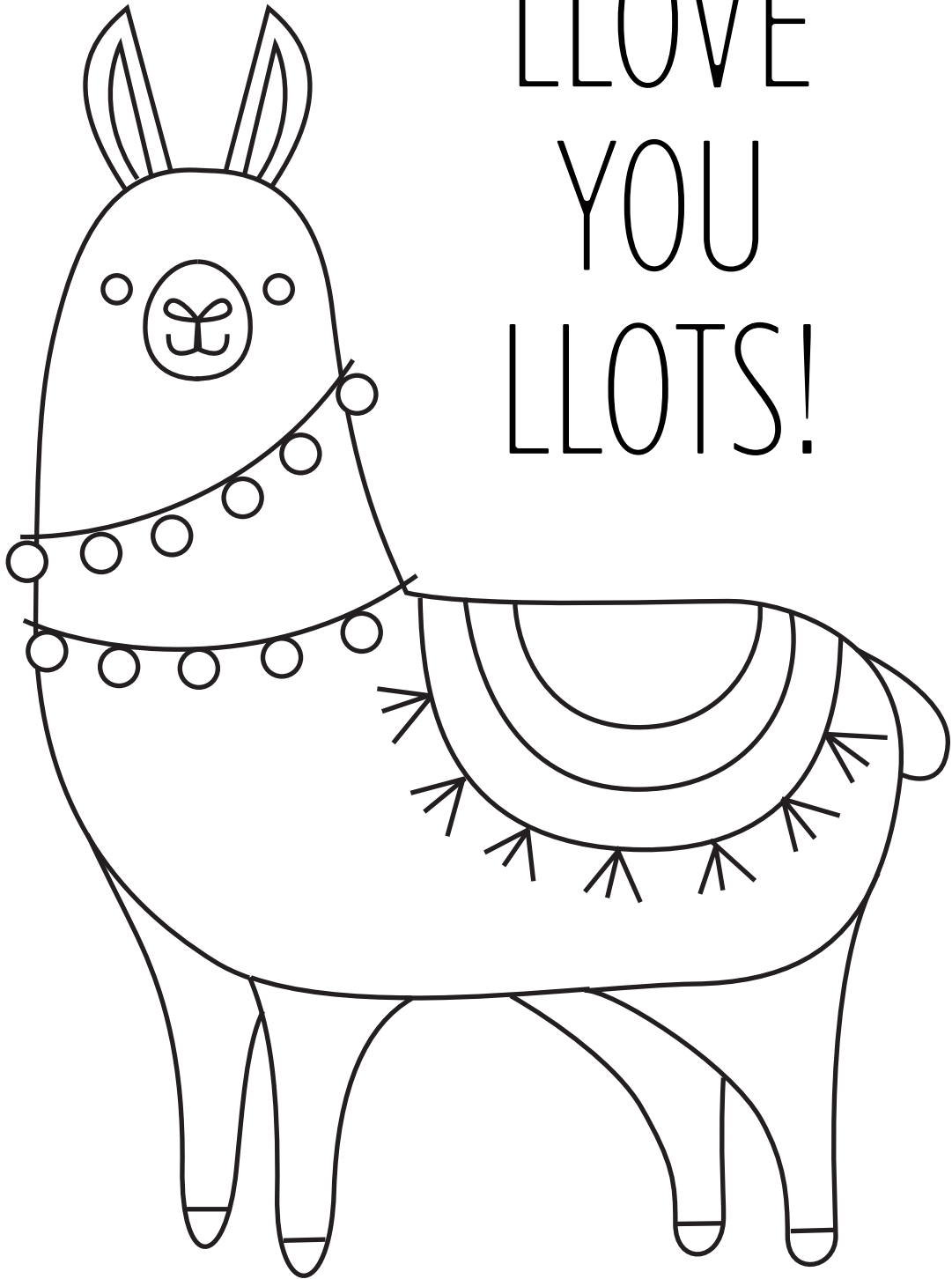

Love Burst



# Love Burst Tutorial

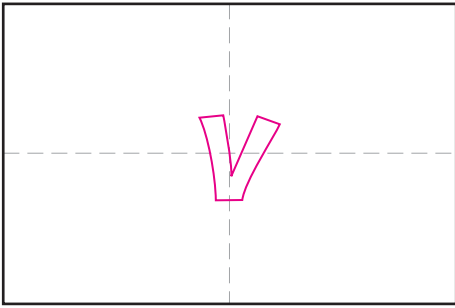

1. Fold to make guide lines. Draw a block letter "V".

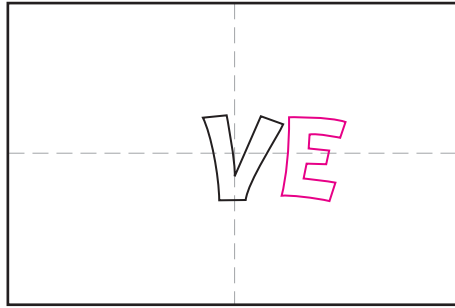

2. Draw a block letter "E".

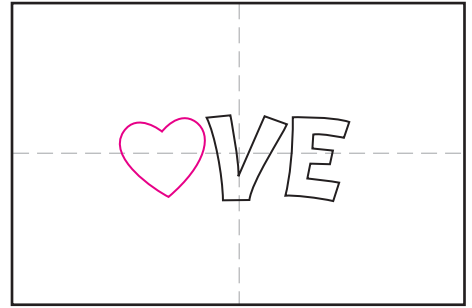

3. Draw a heart for the O.

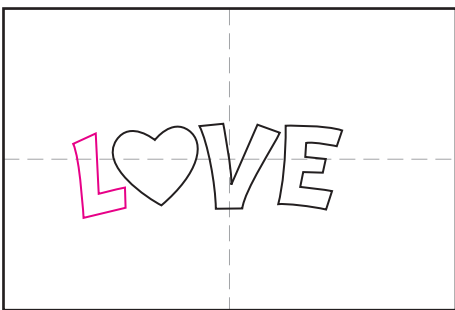

4. Draw a block letter "L".

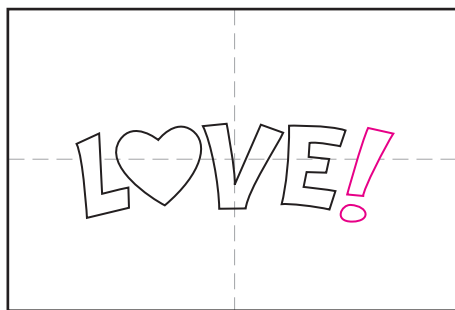

5. Draw a block exclamation point.

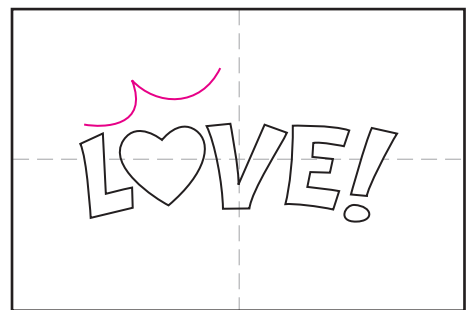

6. Start the burst.

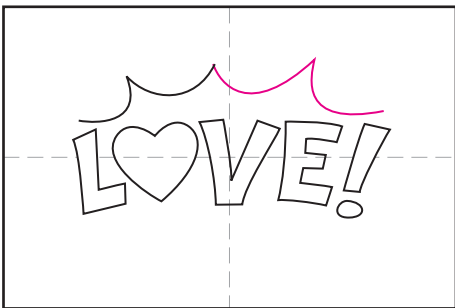

7. Continue the burst.

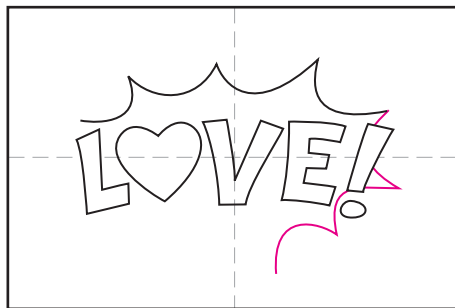

8. Continue the burst through and BEHIND the exclamation point.

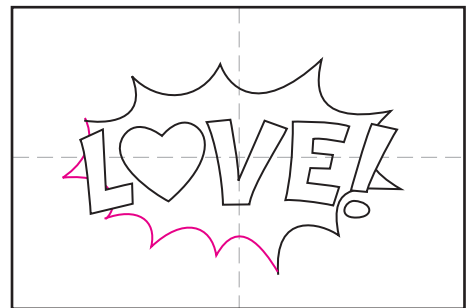

9. Finish the burst through and BEHIND the "L" letter.

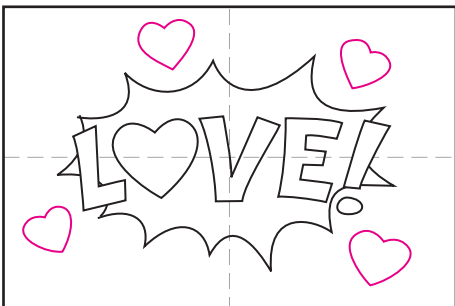

10. Draw four large hearts.

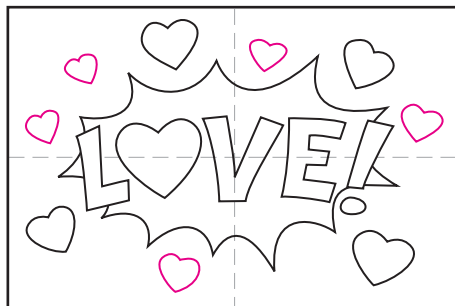

11. Add smaller hearts all around.



12. Trace with a RediSharp black marker and paint with Prang Oval 16 watercolors.

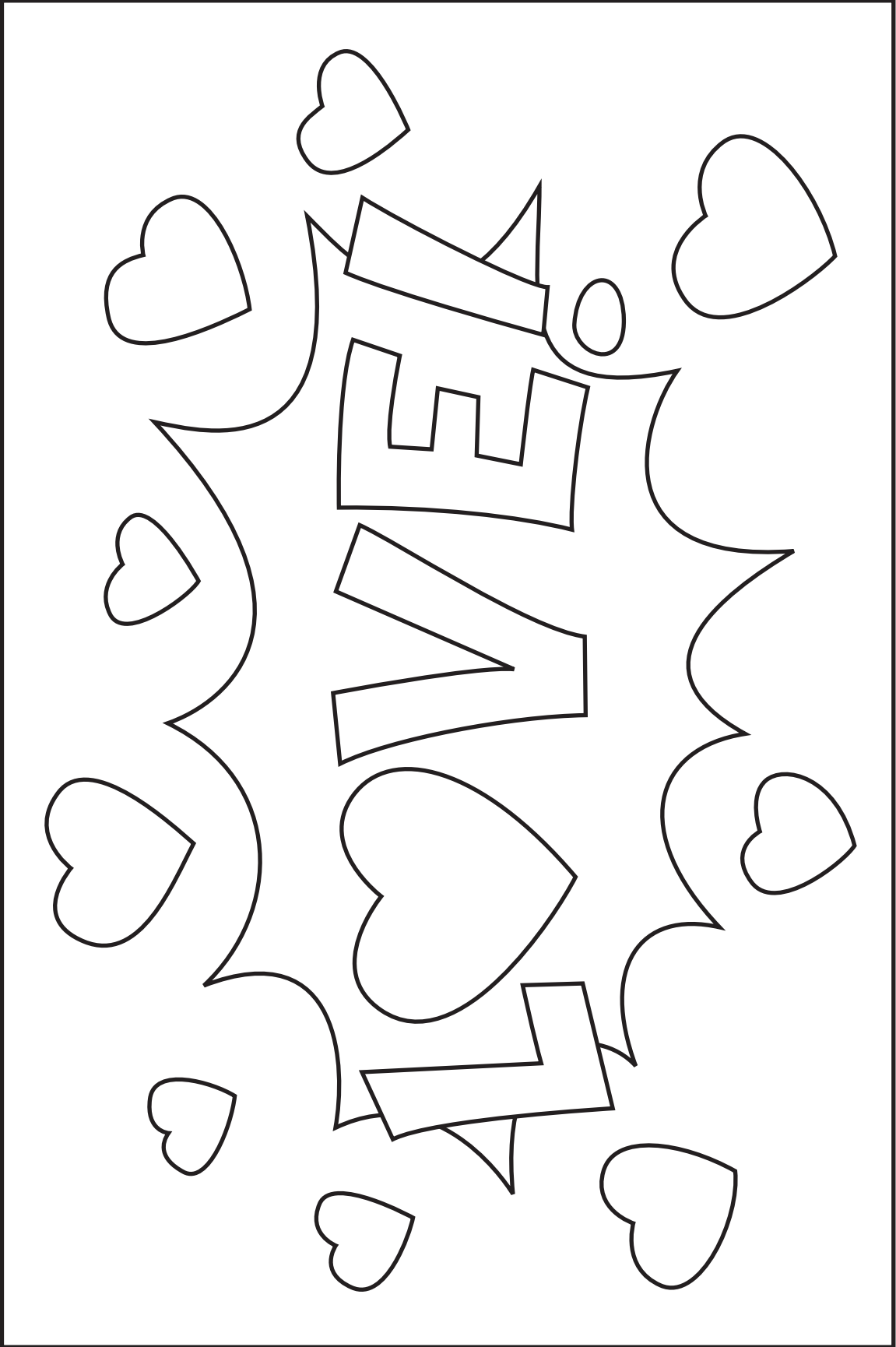

LOVE Color Wheel

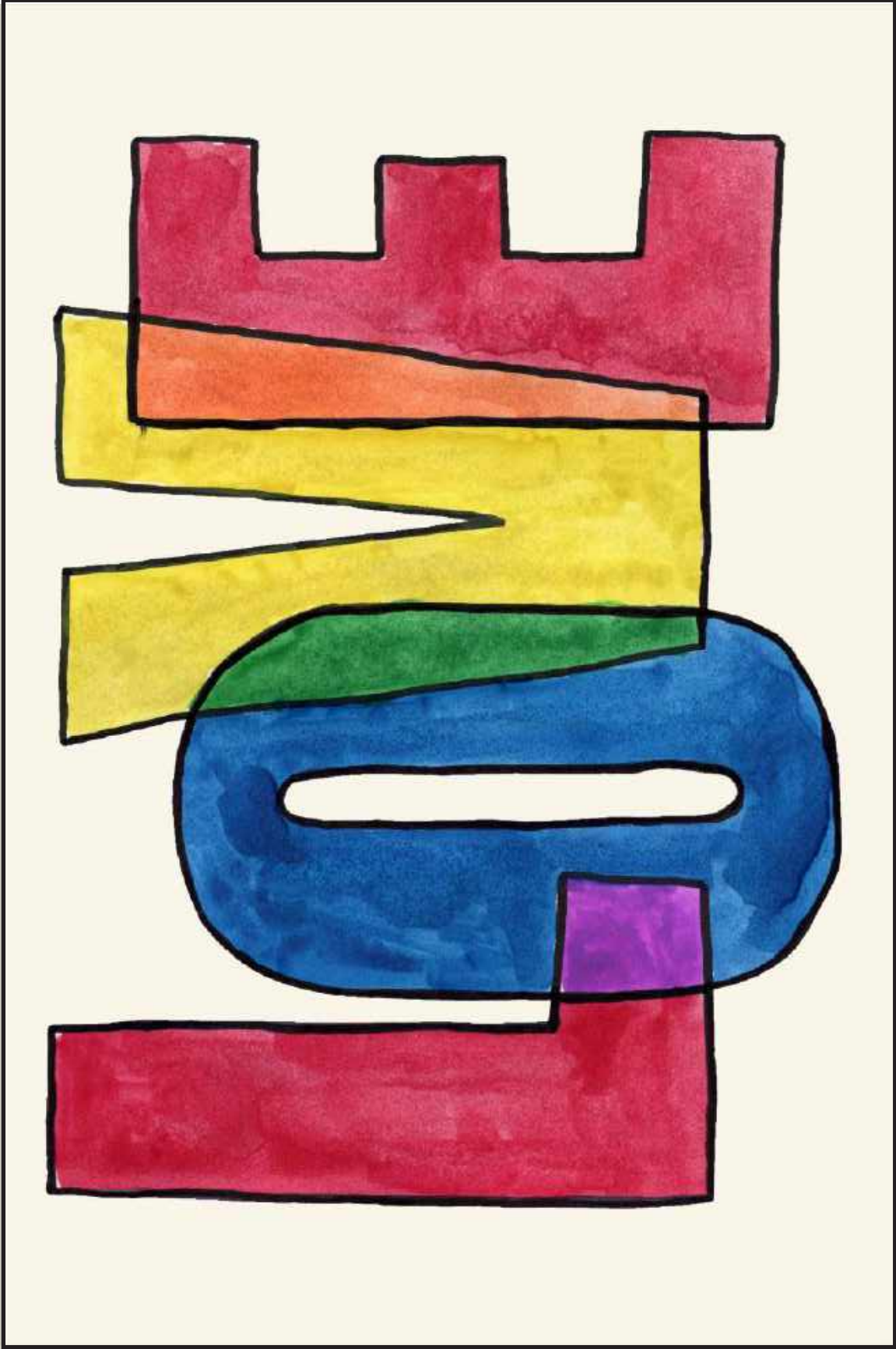

# LOVE Color Wheel Tutorial

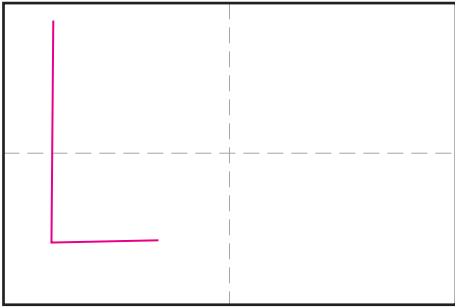

1. Fold to make guide lines. Start outside "L".

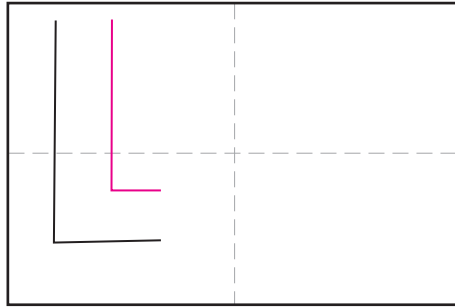

2. Draw inside "L".

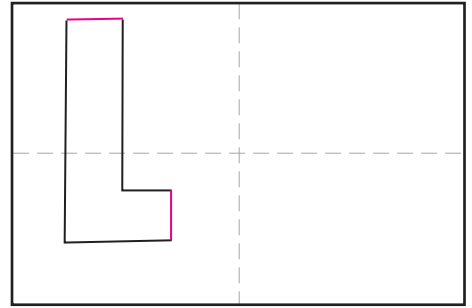

3. Connects the ends.

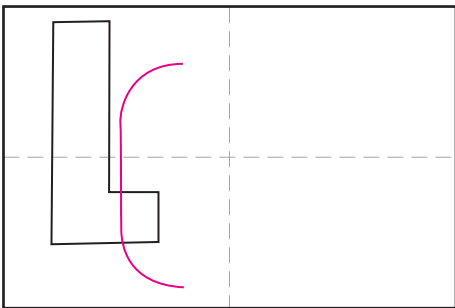

4. Start the "O".

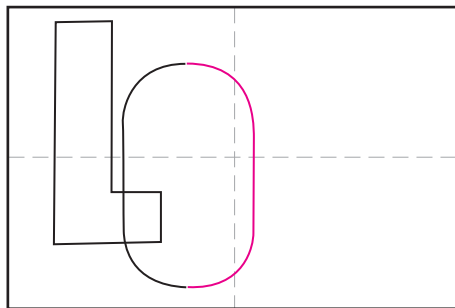

5. Finish the "O".

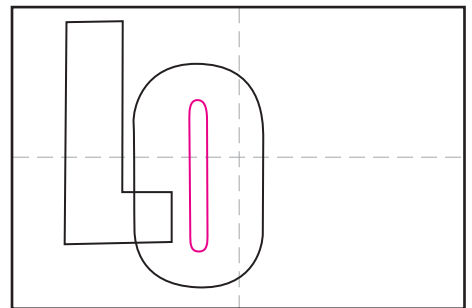

6. Draw the inside "O".

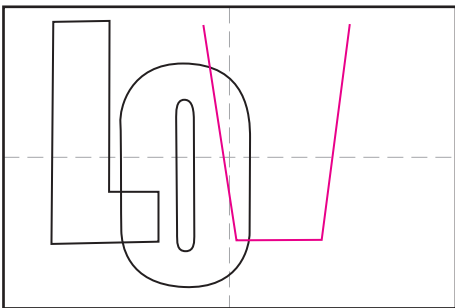

7. Start the outside "V".

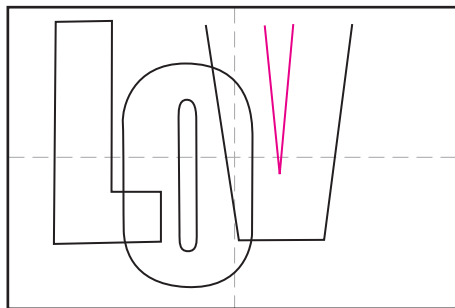

8. Draw the inside "V".

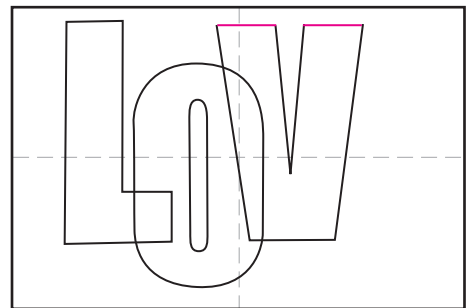

9. Connect the ends.

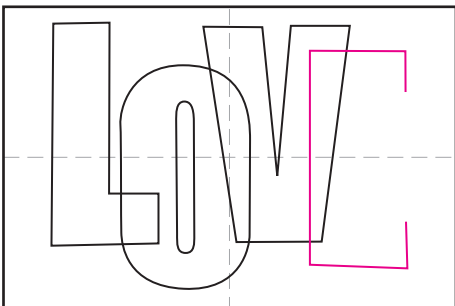

10. Start the "E".

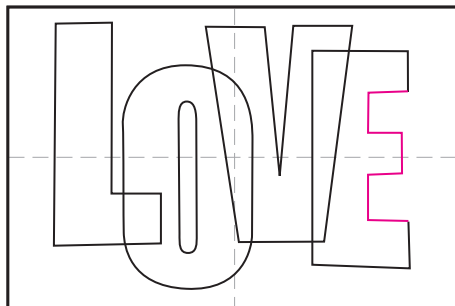

11. Finish the "E".



12. Trace with a RediSharp black marker and paint with Prang Oval 16 watercolors.

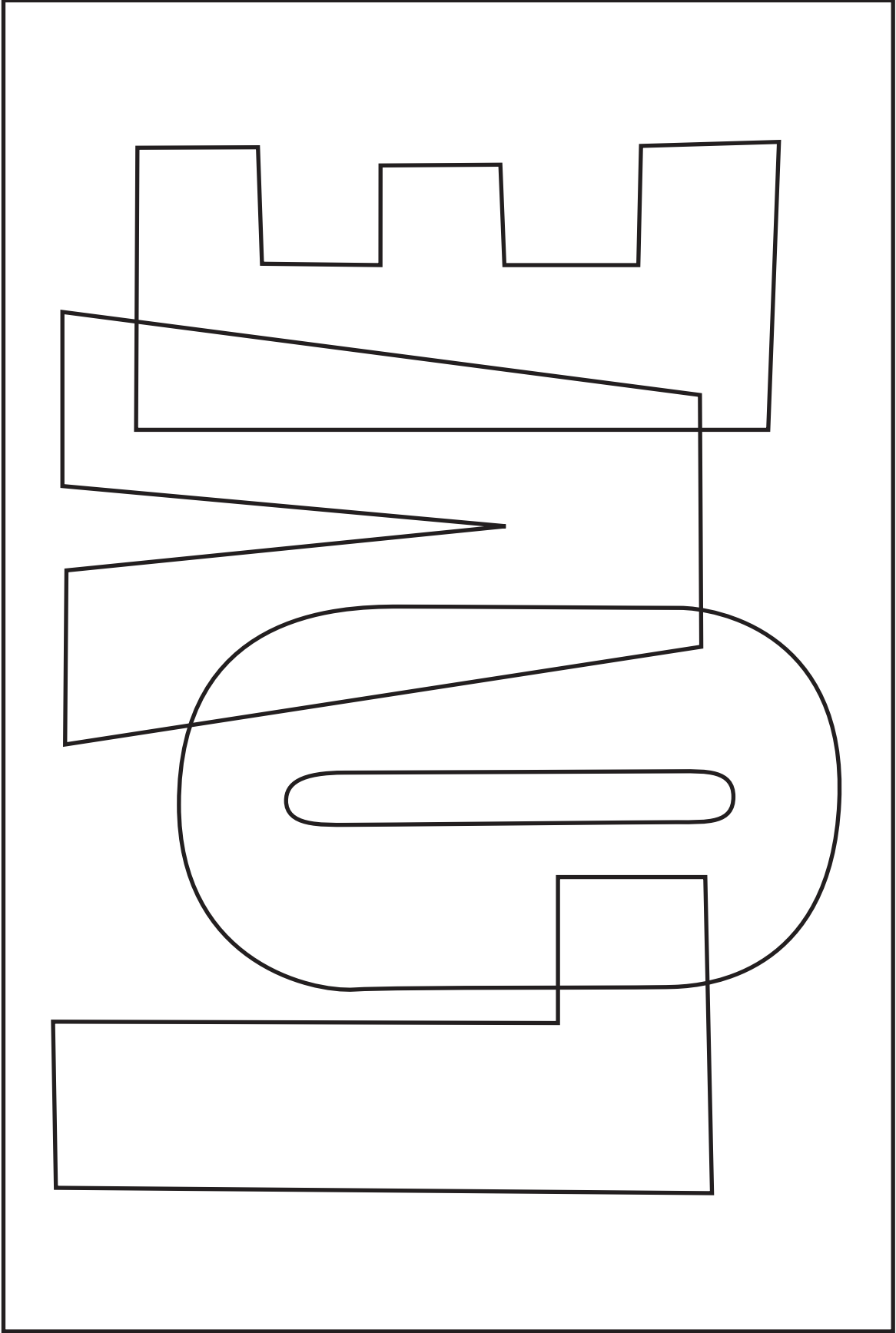

“I Love You” Penguins



# "I Love You" Penguins Tutorial

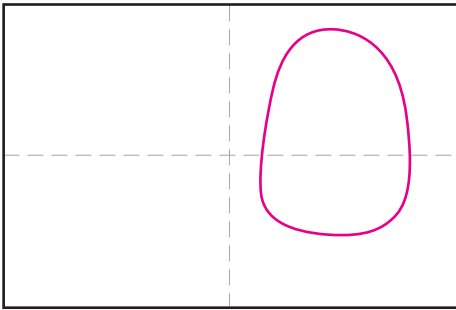

1. Fold to make guide lines. Draw the right oval body.

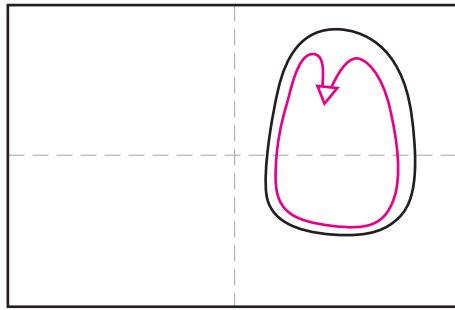

2. Add the inside line with nose.

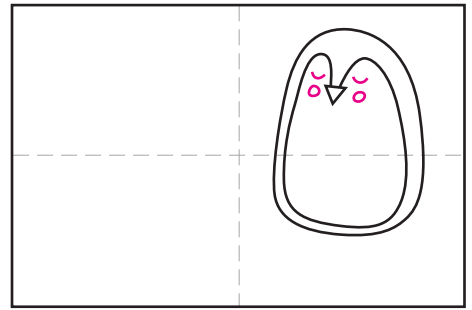

3. Add the eyes and cheeks.

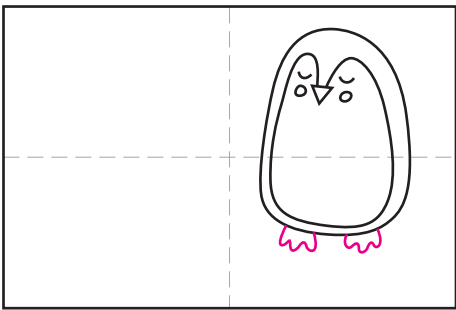

4. Add the two feet.

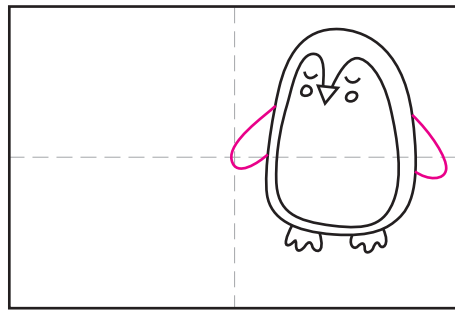

5. Draw two round flipper arms.

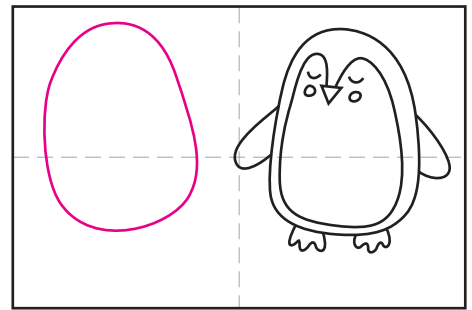

6. Draw the left oval body.

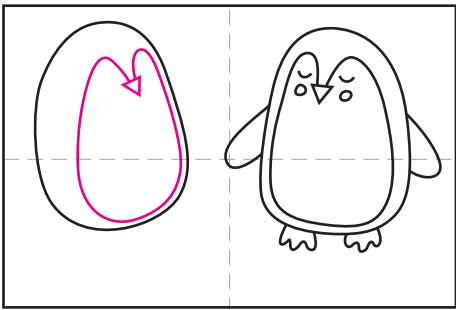

7. Add the inside line with nose.

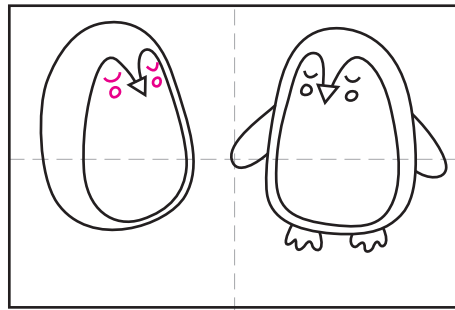

8. Add the eyes and cheeks.

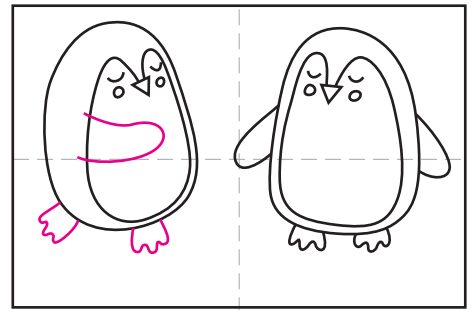

9. Add two feet and one flipper arm.

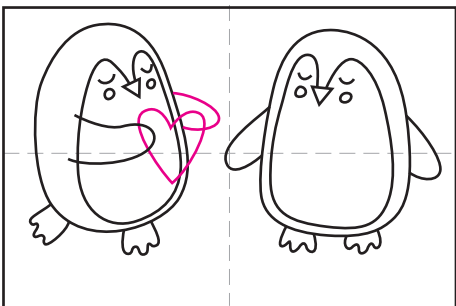

10. Add heart and back flipper arm.

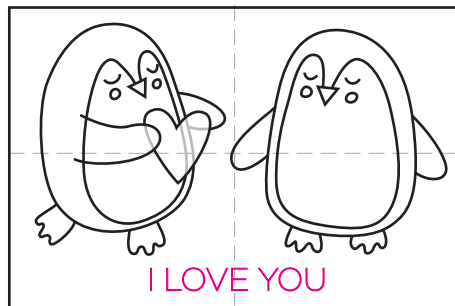

11. Erase lines inside arm and heart. Add "I LOVE YOU" down below.

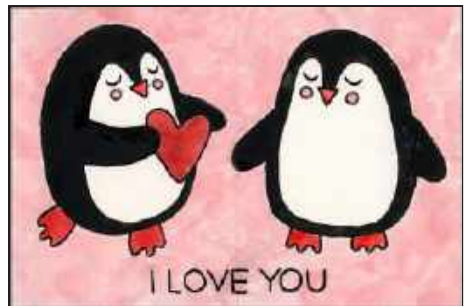

12. Trace with a RediSharp black marker and paint with Prang Oval 16 watercolors.

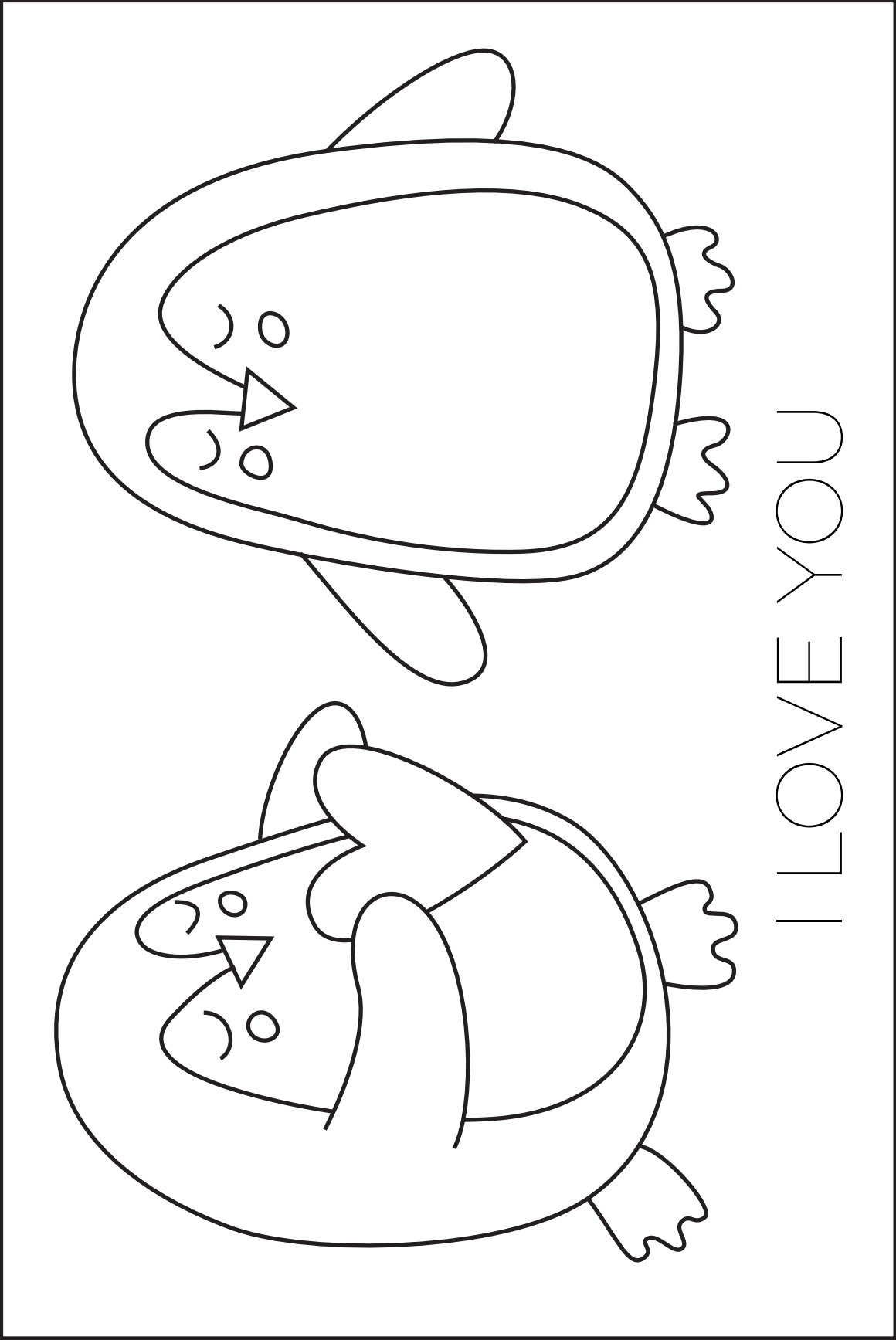

# Rose Tutorial



BE MY VALENTINE

# Rose Tutorial

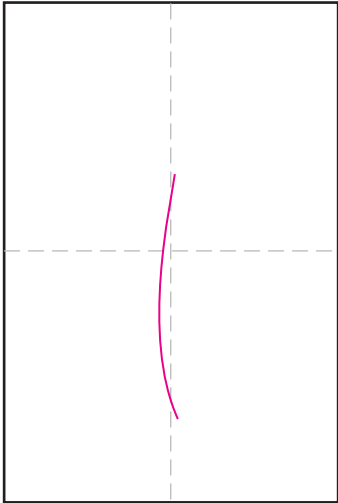

1. Fold to make guide lines. Draw the stem.

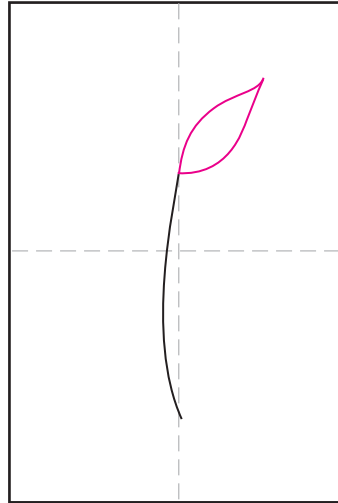

2. Draw the right rose petal.

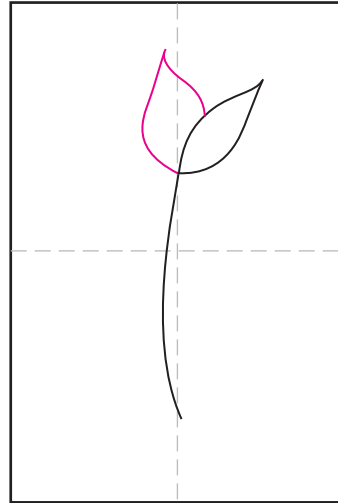

3. Draw the left rose petal behind the right one.

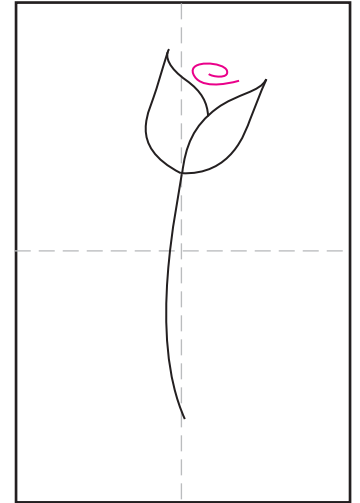

4. Start the swirl of the center of the rose.

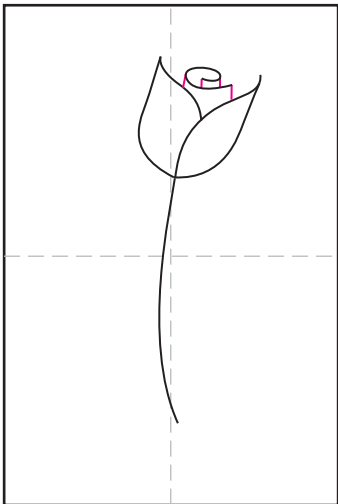

5. Add lines to the side of the swirl.

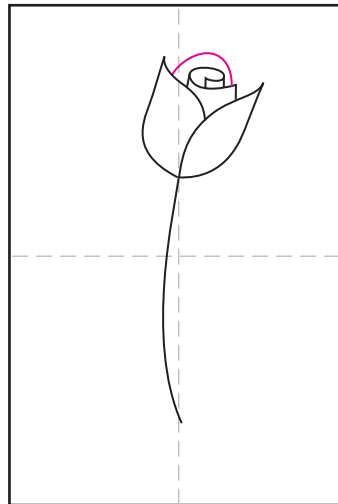

6. Draw a back petal.

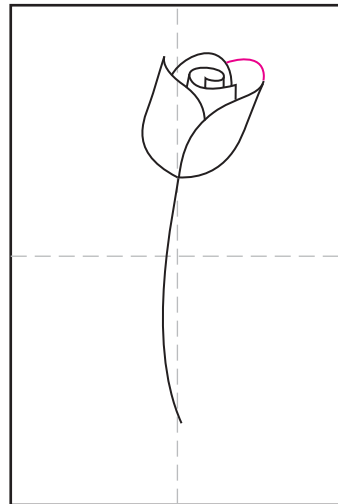

7. Complete the right petal.

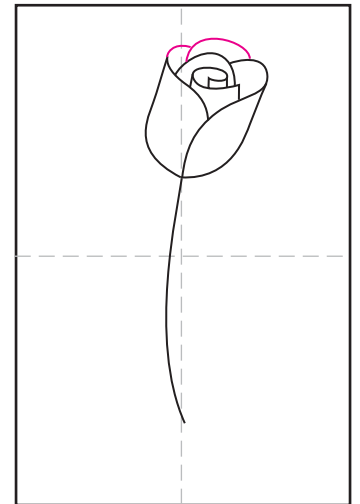

8. Finish with the two back petals.

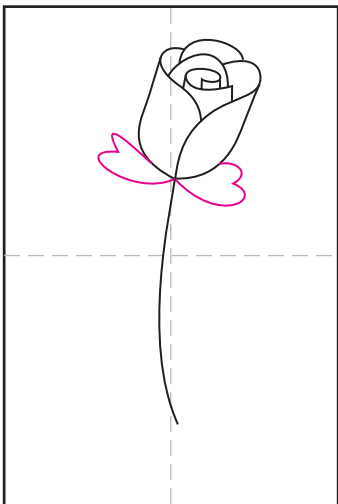

9. Draw two heart leaves.

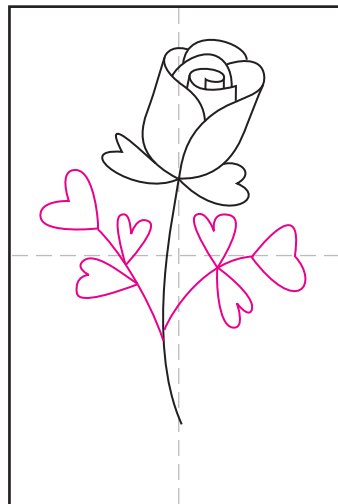

10. Draw side stems with hearts for leaves.

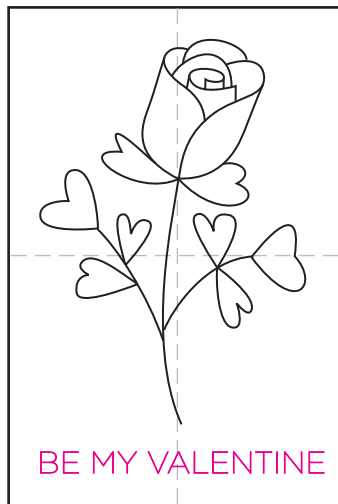

11. Add "BE MY VALENTINE" below.



12. Trace with a RediSharp black marker and paint with Prang Oval 16 watercolors.

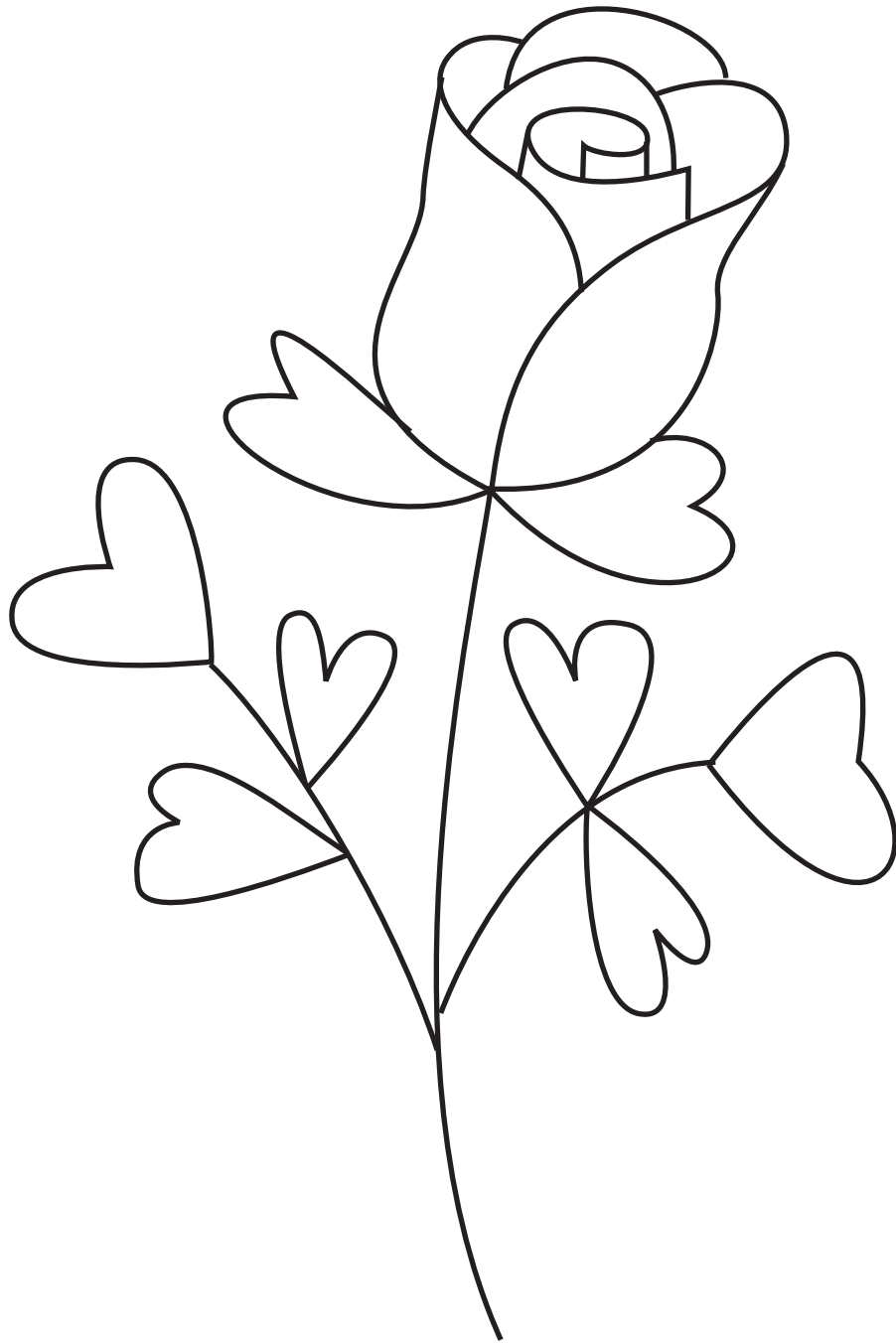

BE MY VALENTINE

# Sock Monkey

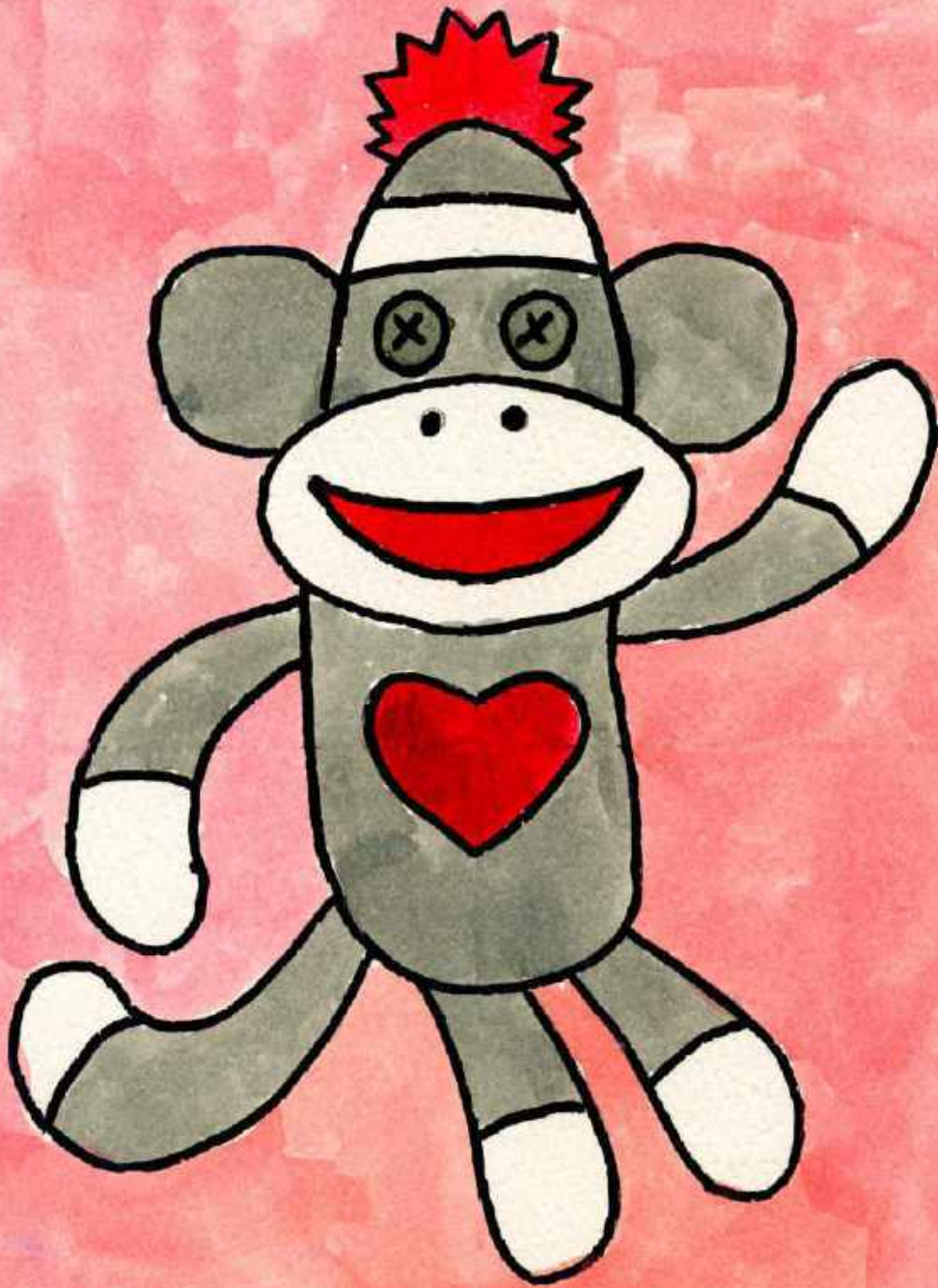

YOU KNOCK MY  
SOCKS OFF!

# Sock Monkey Tutorial

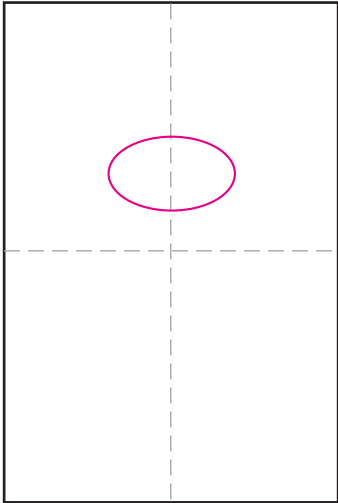

1. Fold to make guide lines. Draw an oval for the mouth.

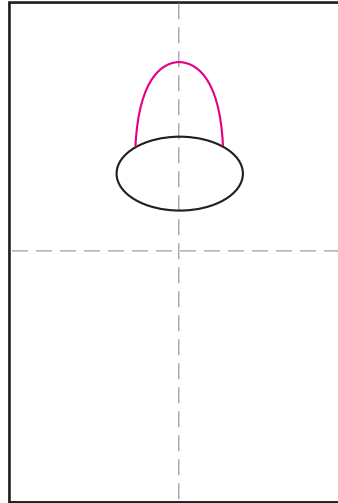

2. Draw the head above.

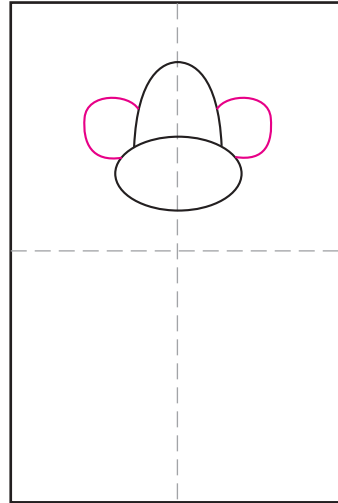

3. Draw two large ears.

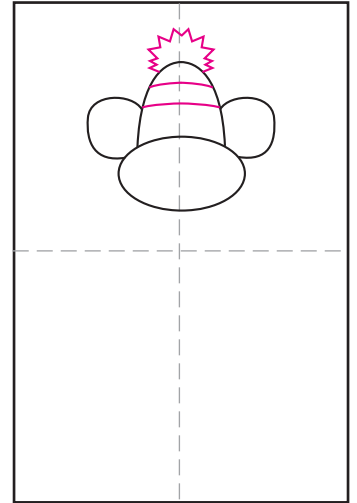

4. Add the hat lines and puff ball.

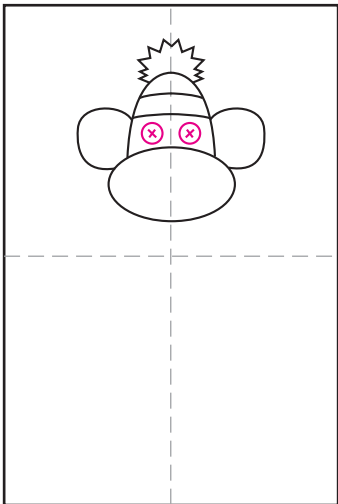

5. Draw two eyes with Xs inside.

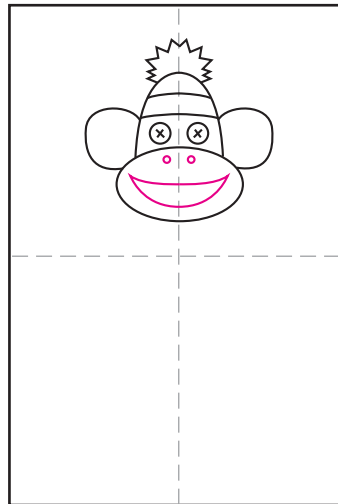

6. Draw the nose and mouth.

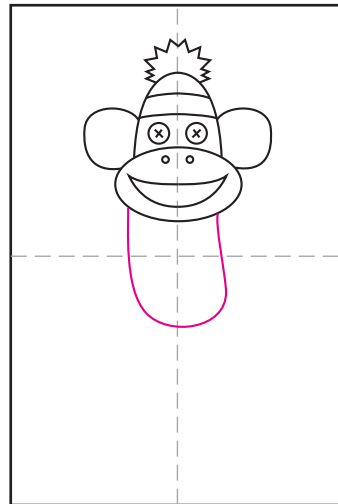

7. Draw a simple body.

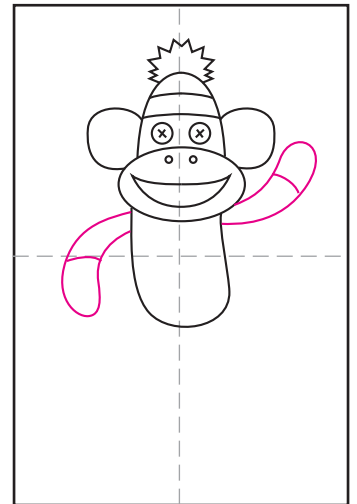

8. Add two arms with lines.

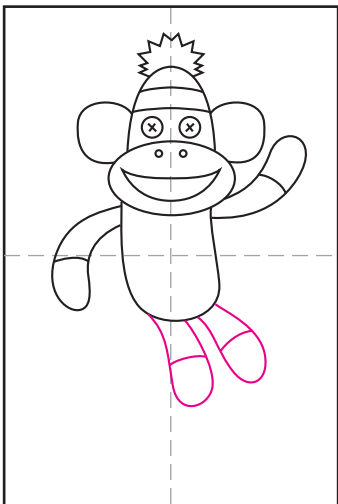

9. Draw two legs with lines.

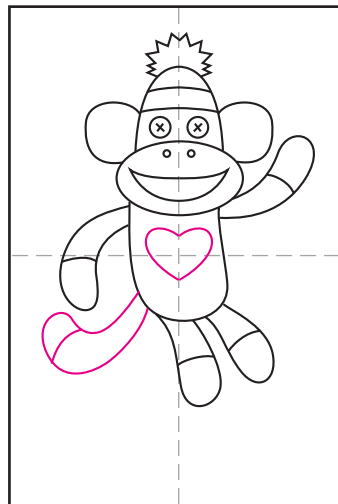

10. Add a tail and heart.

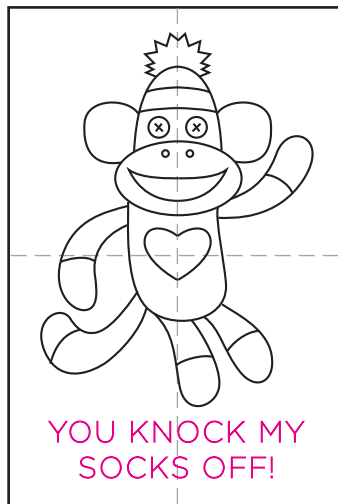

11. Write "You Knock my Socks Off!" below.

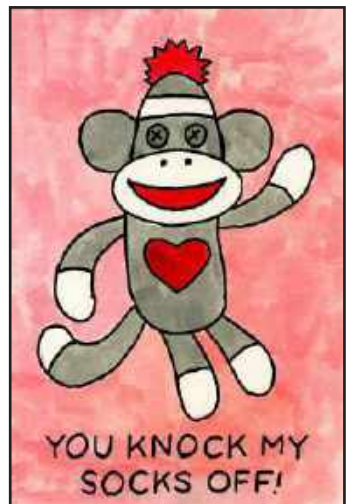

12. Trace with a RediSharp black marker and paint with Prang Oval 16 watercolors.

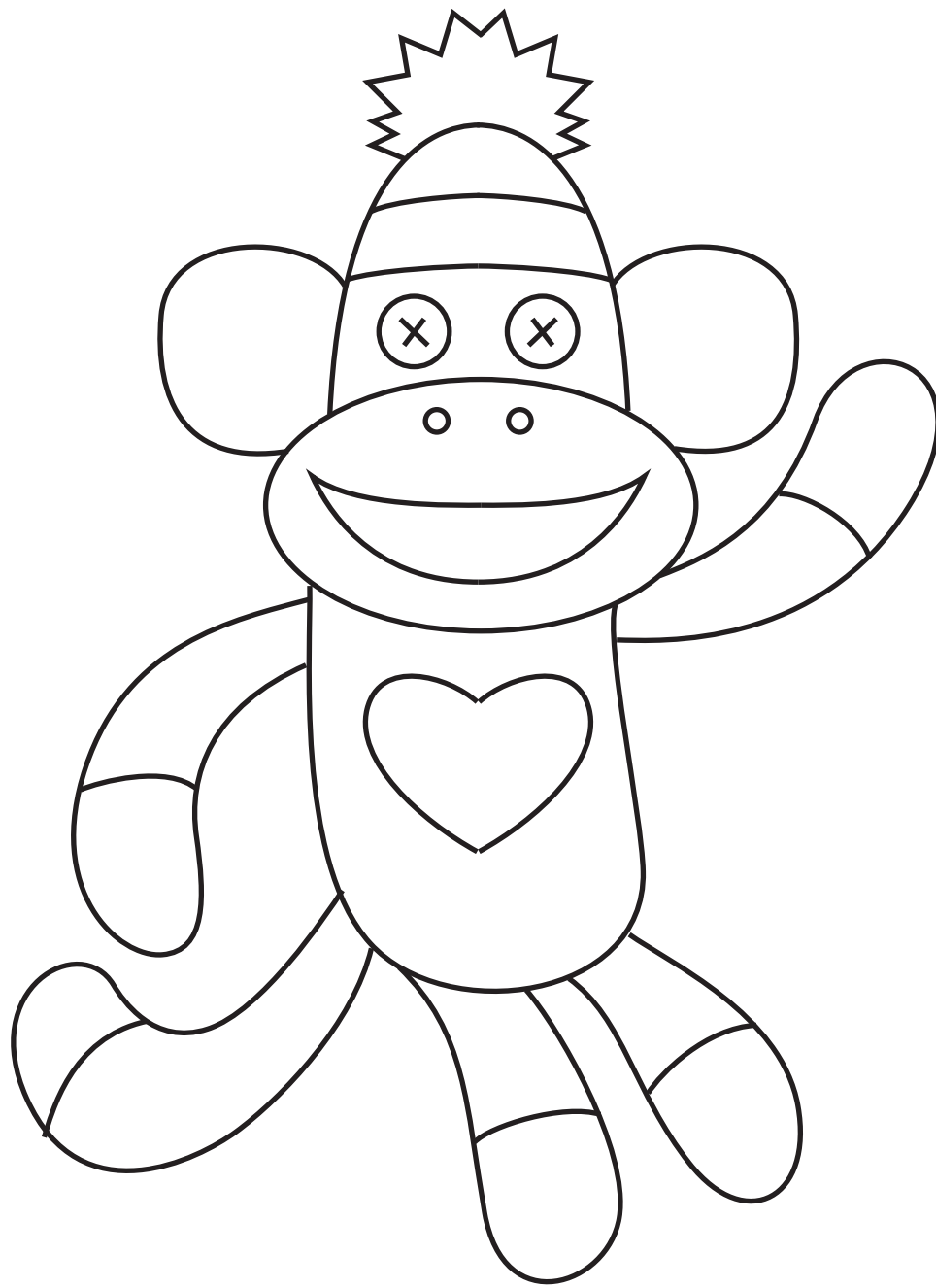

YOU KNOCK MY  
SOCKS OFF

# Teddy Bear



# Teddy Bear Tutorial

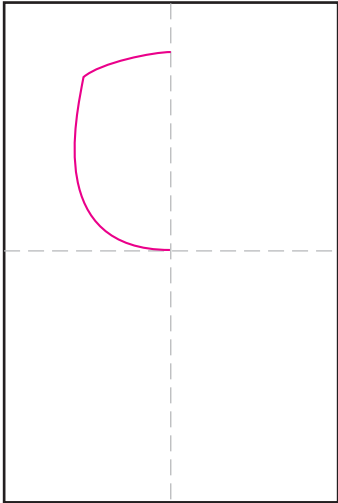

1. Fold to make guide lines. Draw left side of the head.

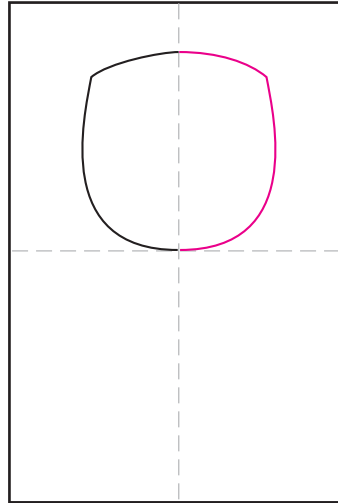

2. Draw a matching right side of the head.

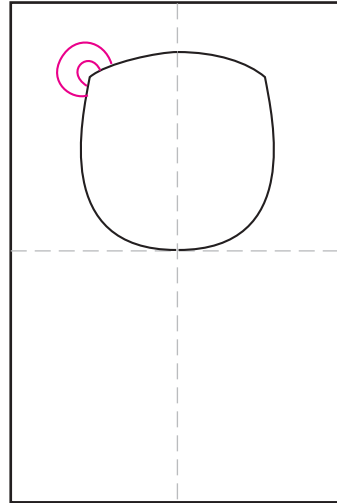

3. Draw one ear.

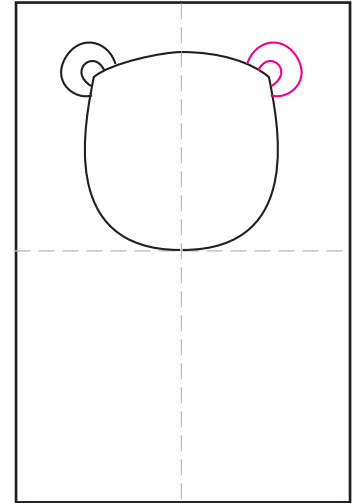

4. Add the other ear.

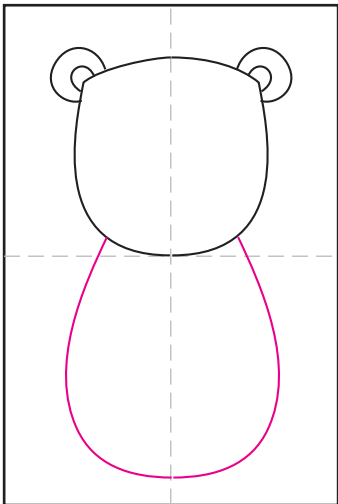

5. Draw the body.

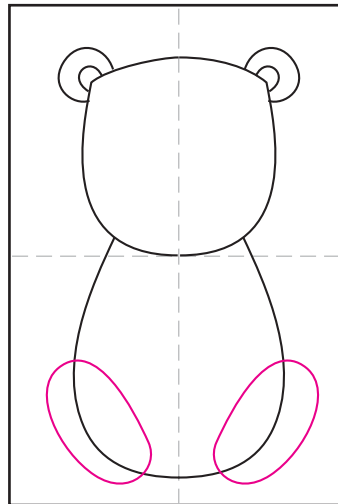

6. Add two feet.

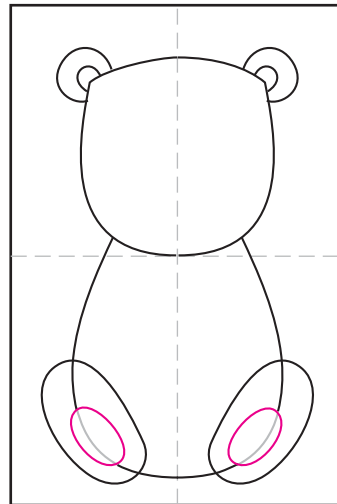

7. Erase the inside lines and add two small foot pads.

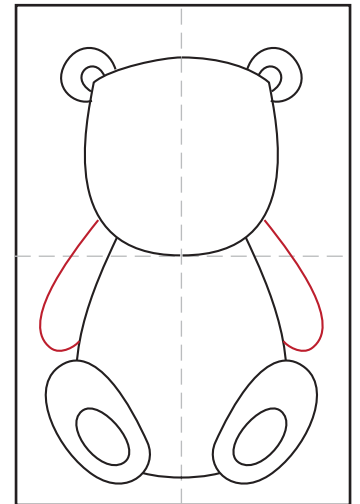

8. Draw two simple arms.

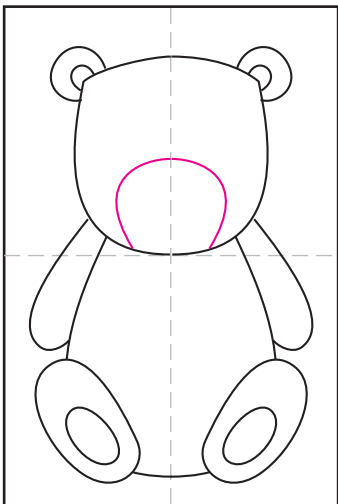

9. Draw the muzzle.

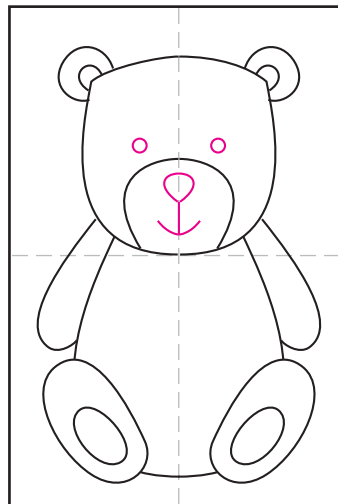

10. Add mouth and eyes.

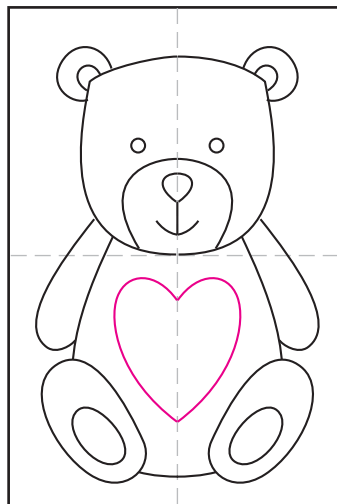

11. Draw a heart on the belly. Add a message inside if you wish.



12. Trace with a RediSharp black marker and paint with Prang Oval 16 watercolors.

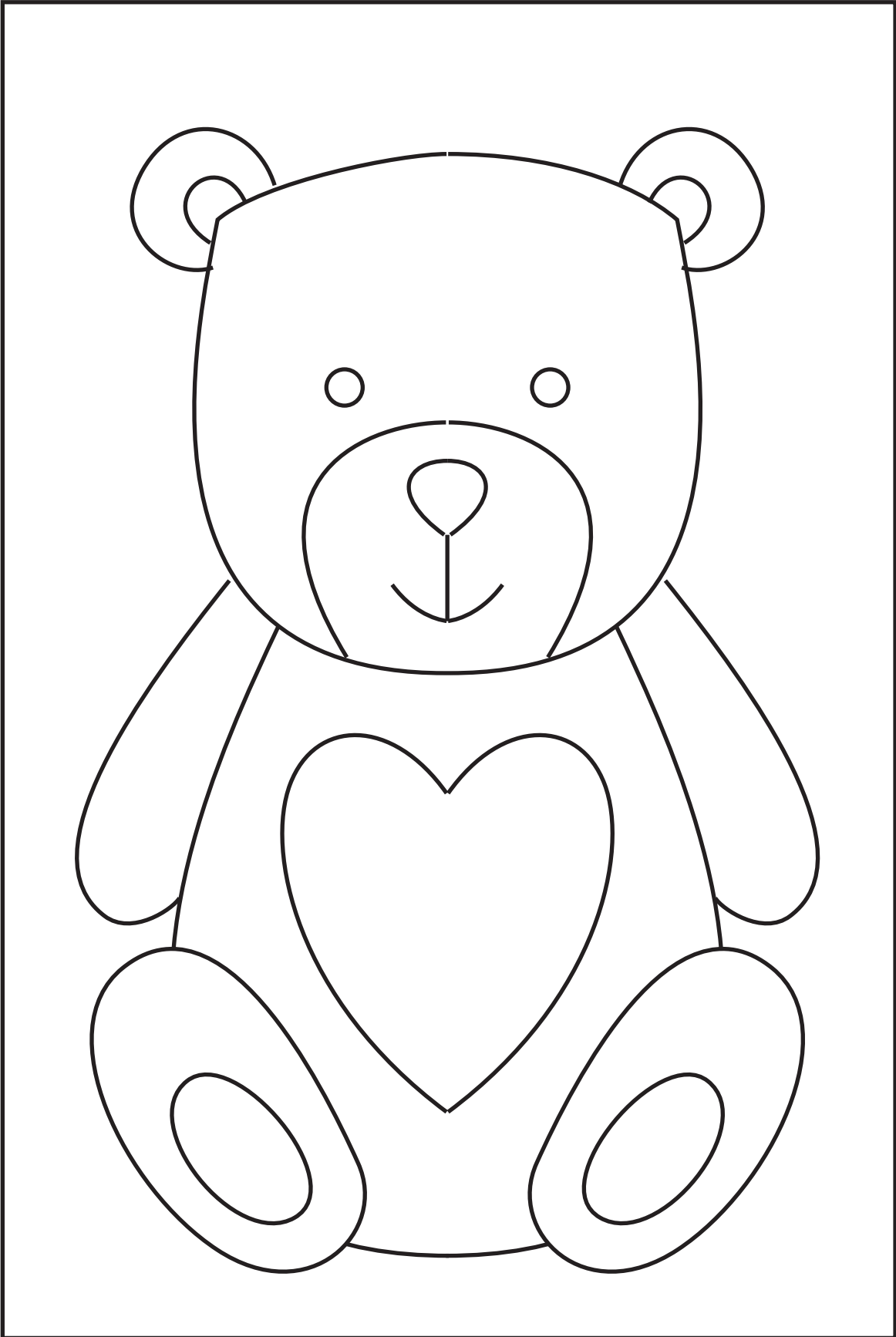

# Bear Holding a Heart



# Bear Holding a Heart Tutorial

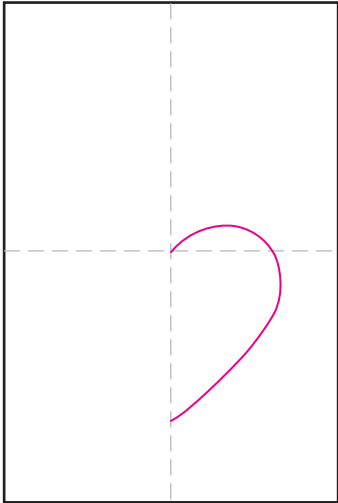

1. Fold to make guide lines. Draw the right side of the heart.

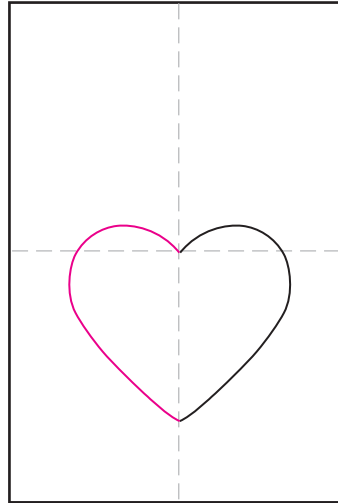

2. Draw a matching left side of the heart.

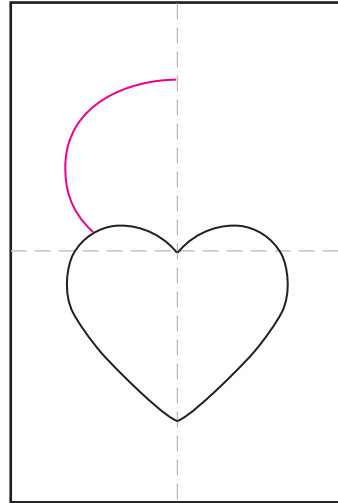

3. Draw the left side of the head.

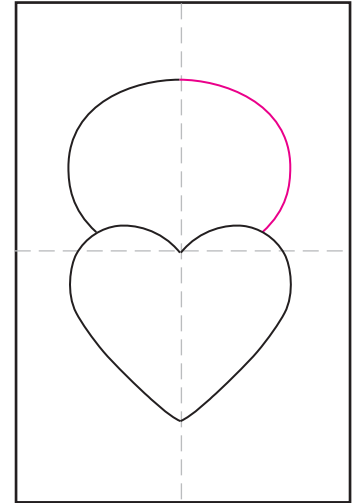

4. Draw the right side of the head.

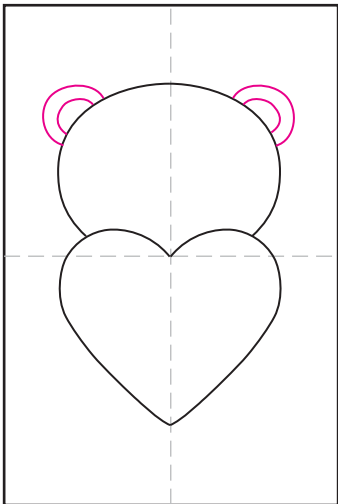

5. Draw two ears.

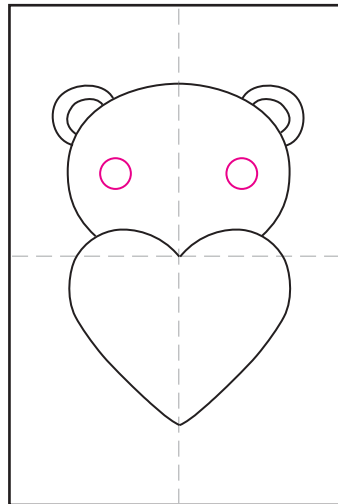

6. Draw two eyes.

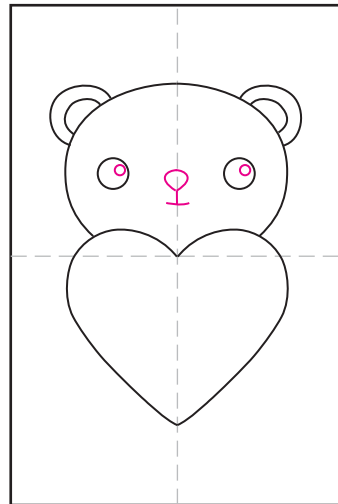

7. Finish the face.

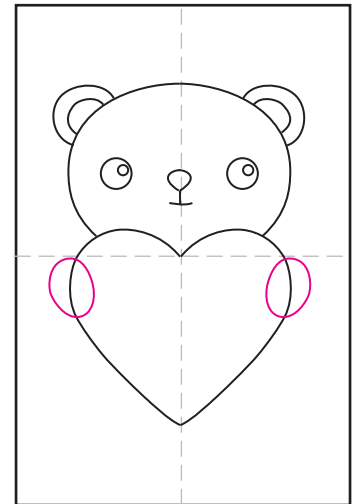

8. Draw two paws.

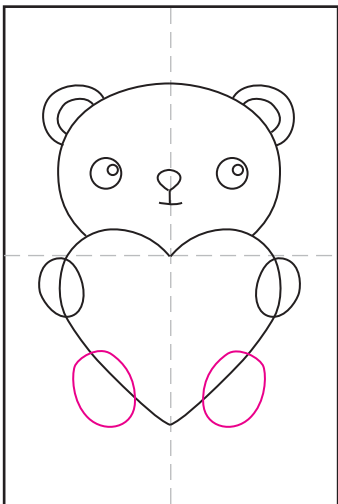

9. Draw two feet.

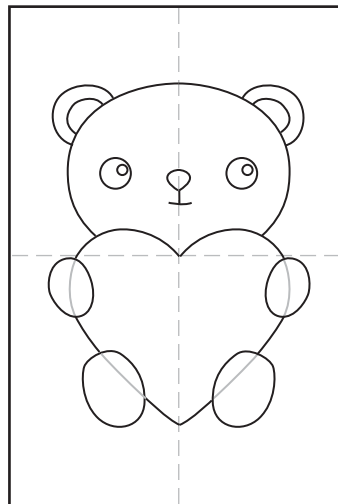

10. Erase the lines inside the paws and feet.

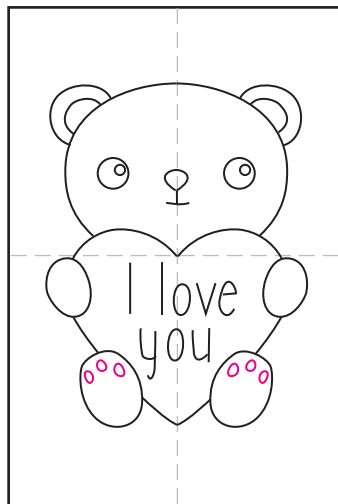

11. Add toe pads. Write "I LOVE YOU" in the heart.



12. Trace with a RediSharp black marker and paint with Prang Oval 16 watercolors.



# Unicorn Valentine

Be My  
Valentine

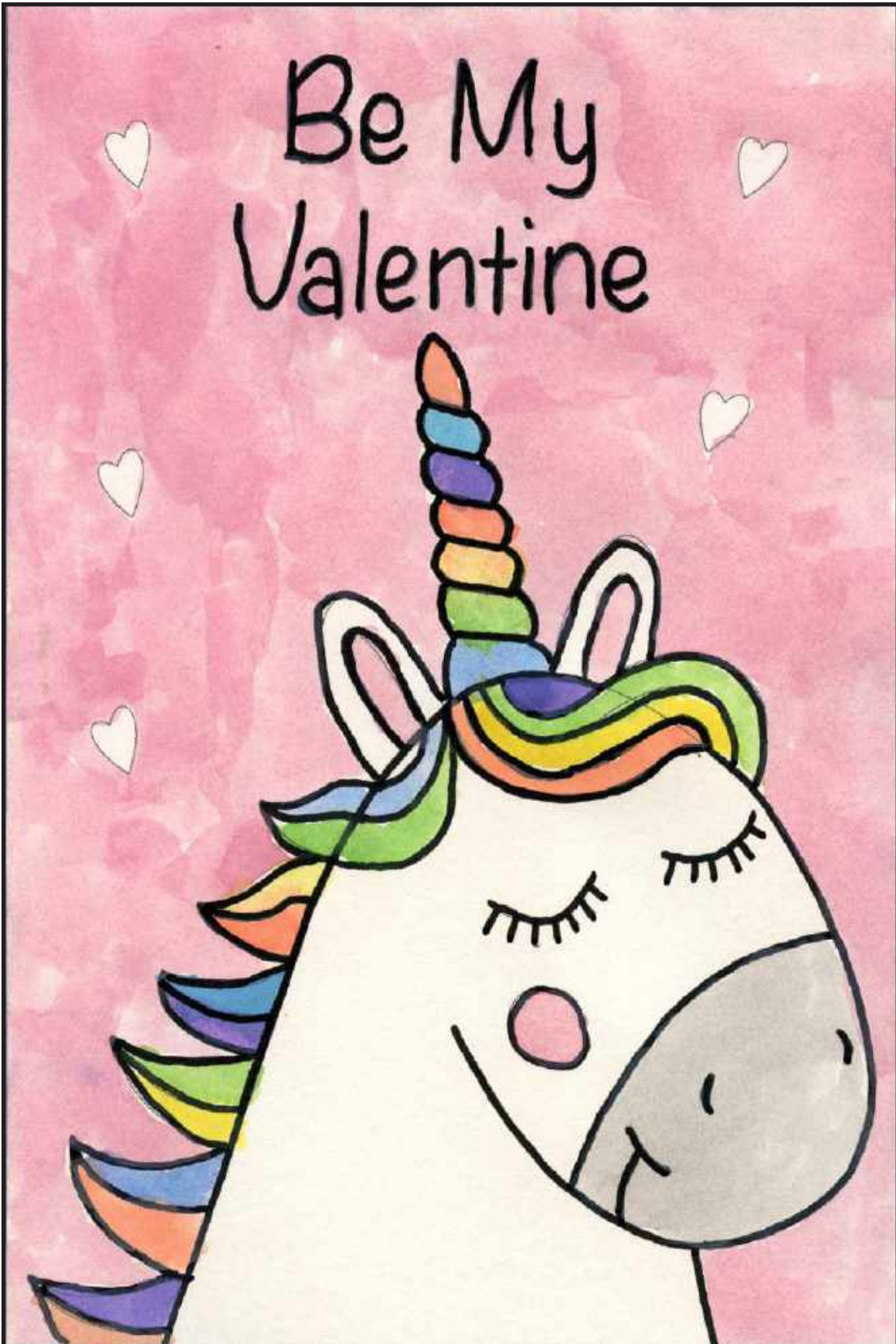

# Unicorn Valentine Tutorial

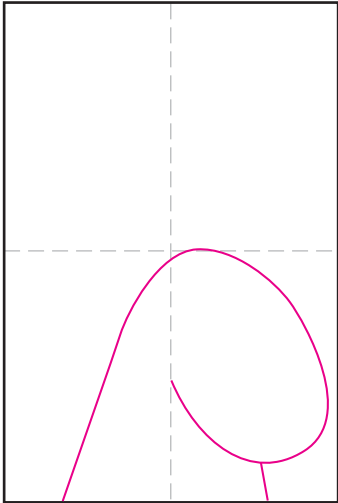

1. Fold to make guide lines. Draw the head and neck.

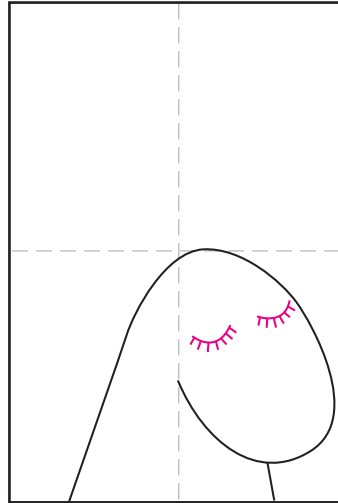

2. Add eyelashes.

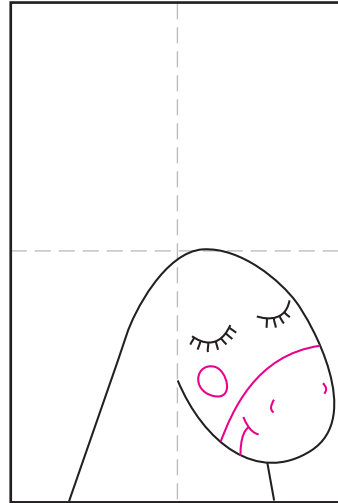

3. Draw the muzzle line. Add cheek and mouth details.

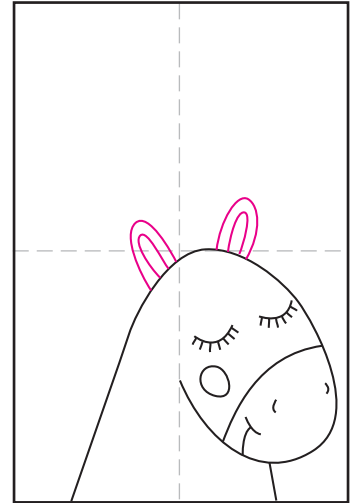

4. Draw two ears.

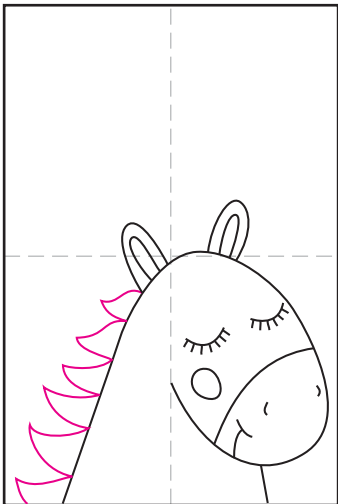

5. Draw a back mane.

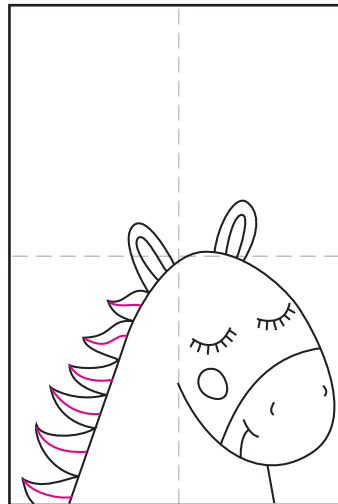

6. Add mane details.

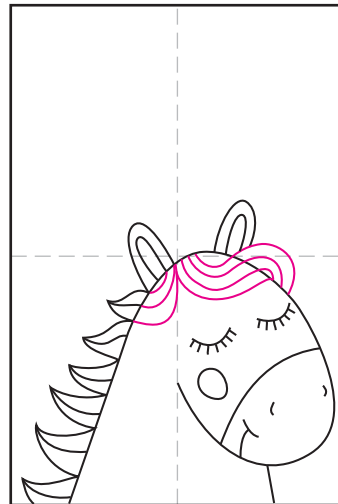

7. Finish the top mane.

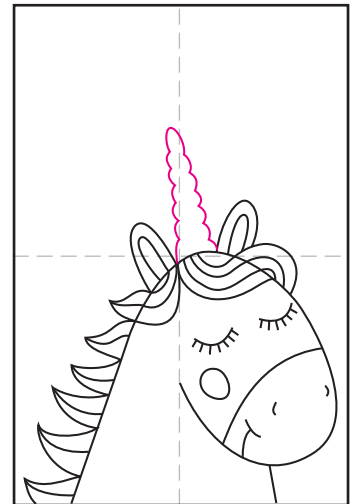

8. Start the horn. Try to make the same number of bumps on each side.

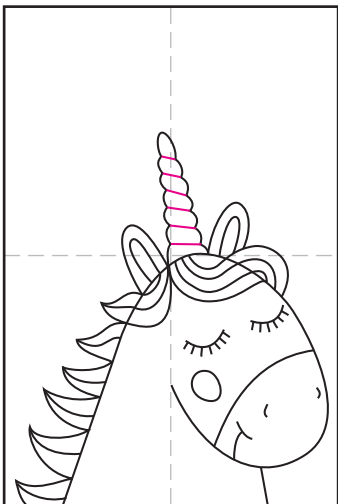

9. Finish horn with lines.

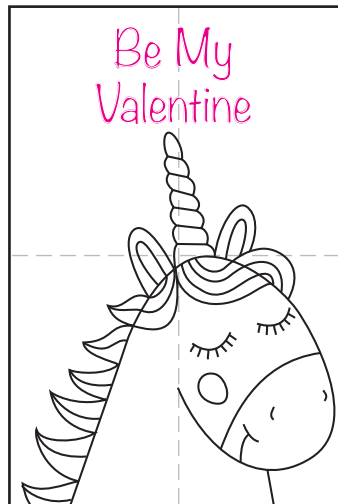

10. Write "Be My Valentine"

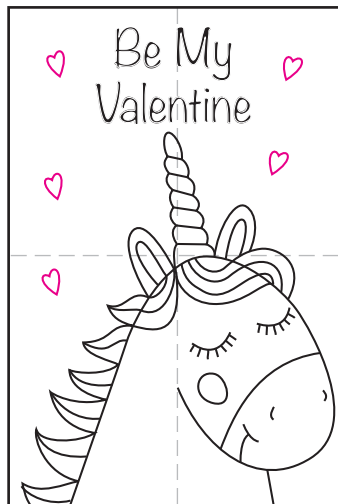

11. Add hearts all around.



12. Trace with a RediSharp black marker and paint with Prang Oval 16 watercolors.

# Be My Valentine



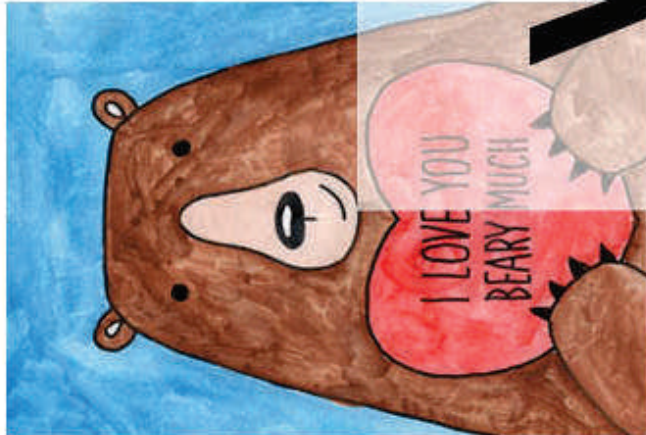
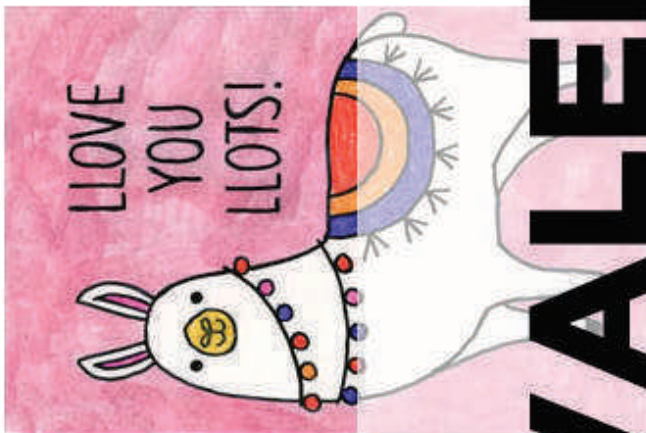
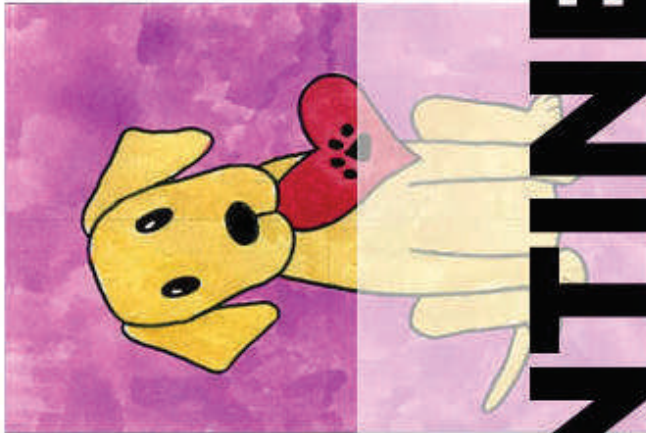

# VALENTINE

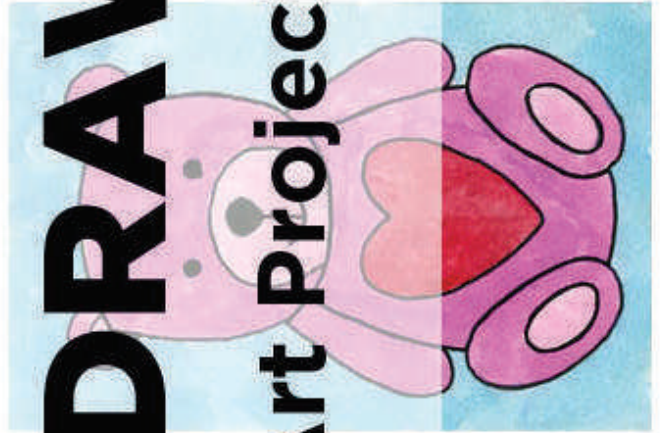
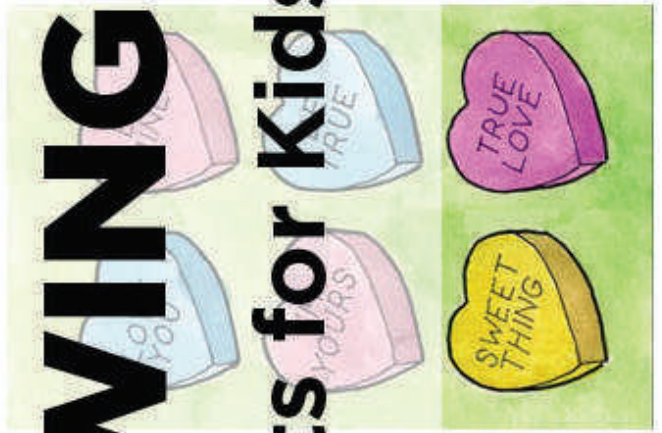
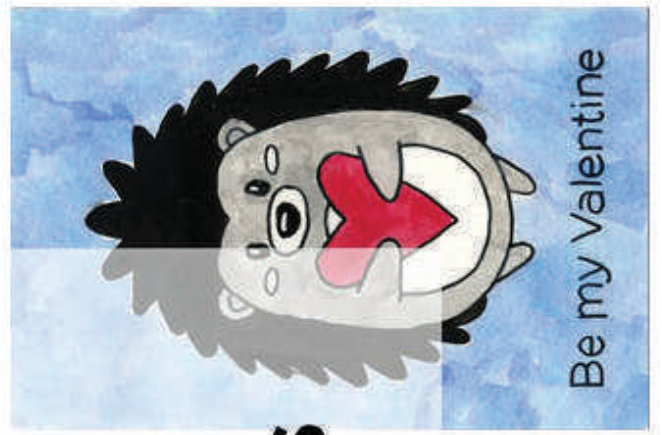

# DRAWING

## Art Projects for Kids

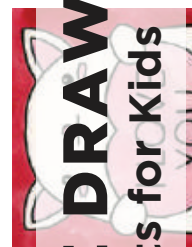
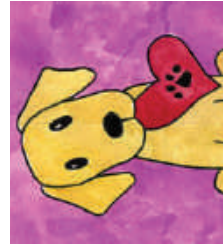
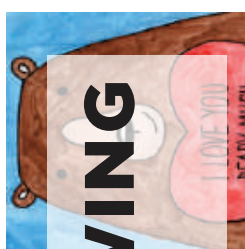

# VALENTINE DRAWING

Art Projects for Kids

# VALENTINE DRAWING

Art Projects for Kids

# VALENTINE DRAWING

Art Projects for Kids