

How to draw like Delaunay

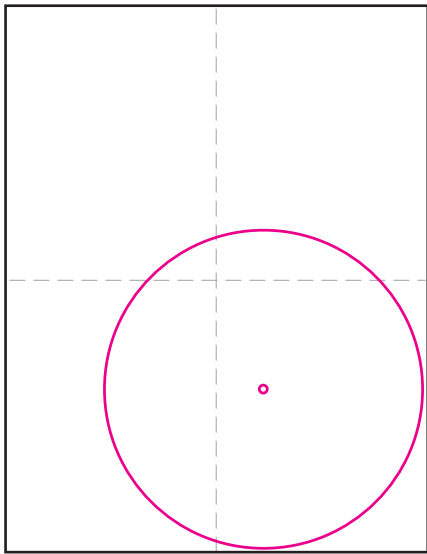

1. Draw very large circle and center dot.

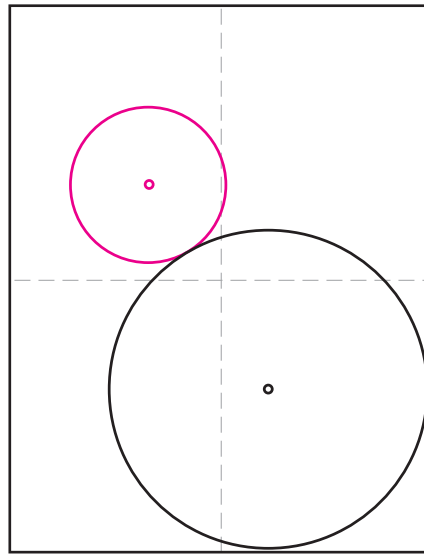

2. Add smaller circle and center dot.

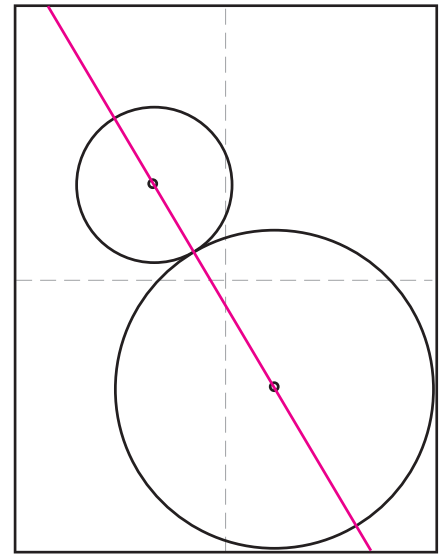

3. Use a straight edge to connect dots.

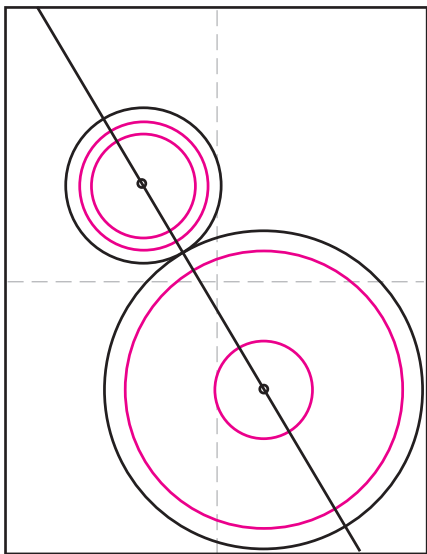

4. Add concentric circles. The goal is to have a variety of thick and thin rings.

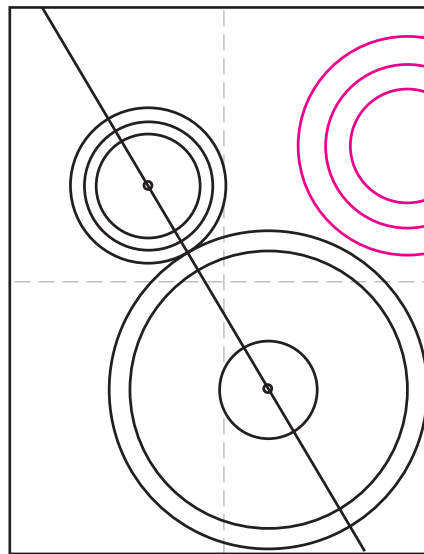

5. Draw another set of larger circles.

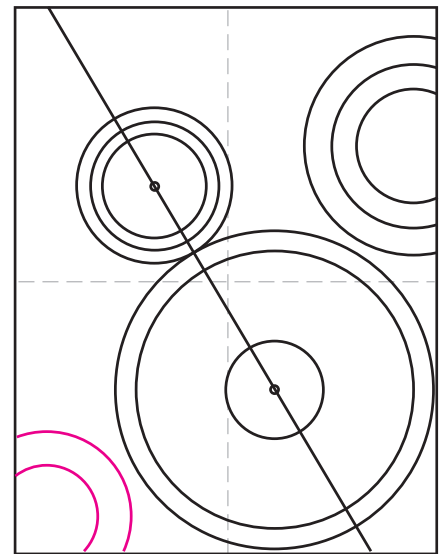

6. Add a smaller set of circles.

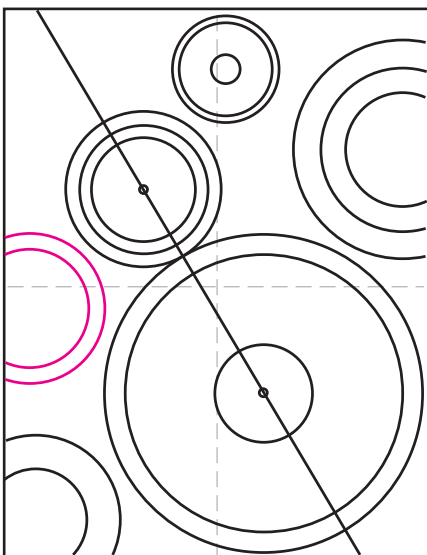

7. Fill in remaining space with circles.

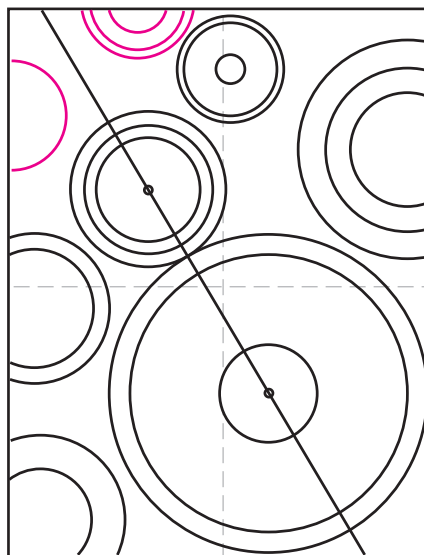

8. Finish smaller spaces with circles. Check to see that there is a variety of thick and thin-looking rings.

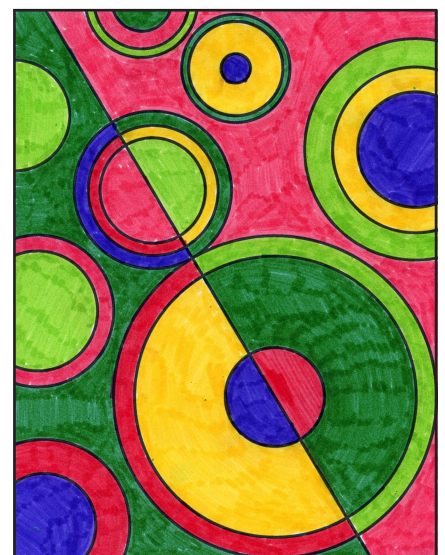

9. Trace with a marker and color. Try limiting yourself to about 6 colors or so. It will force lots of repetition.

Delaunay Art Project

