

Draw a Helicopter

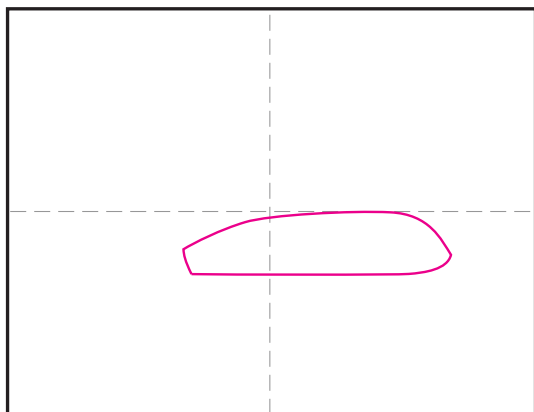

1. Start the fuselage with the middle shape shown.

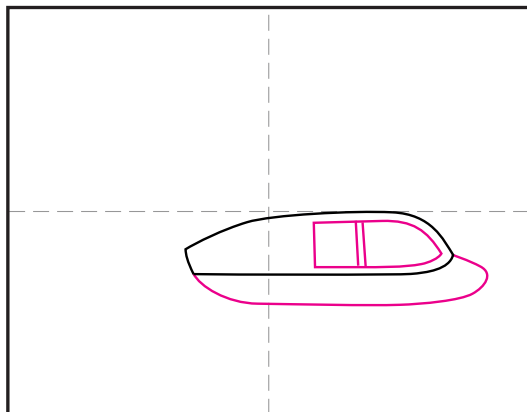

2. Add the windows inside and nose shape below.

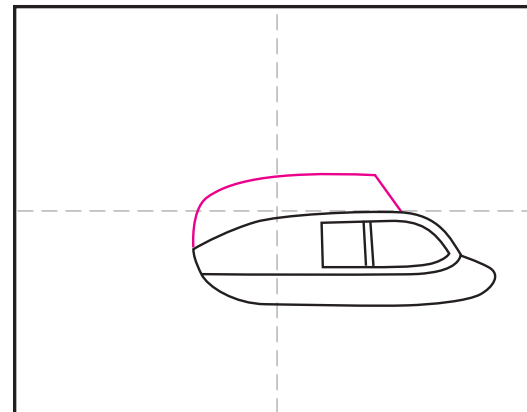

3. Draw the top of the fuselage as shown.

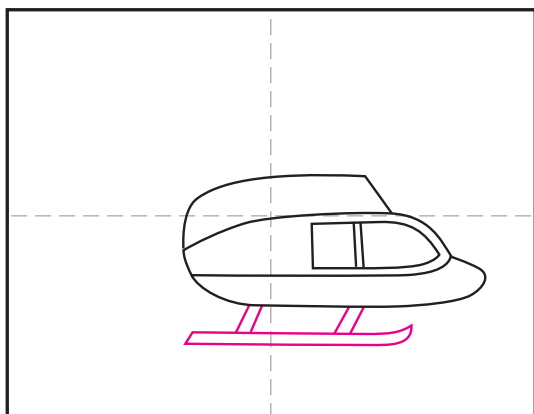

4. Add the skids below the fuselage.

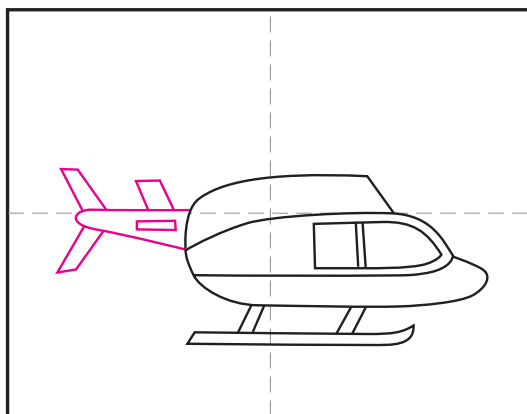

5. Draw the tail boom extending from the back.

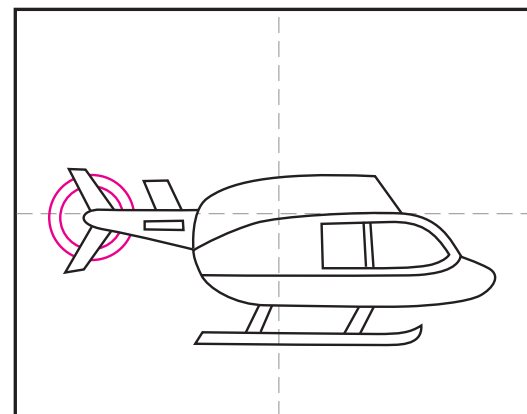

6. Add the round rotor to the tail boom.

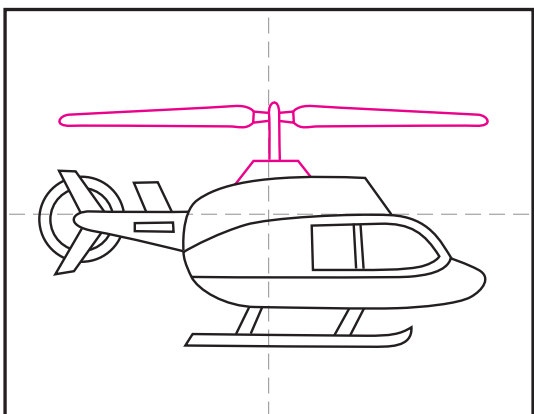

7. Draw the main rotor on top of the fuselage.

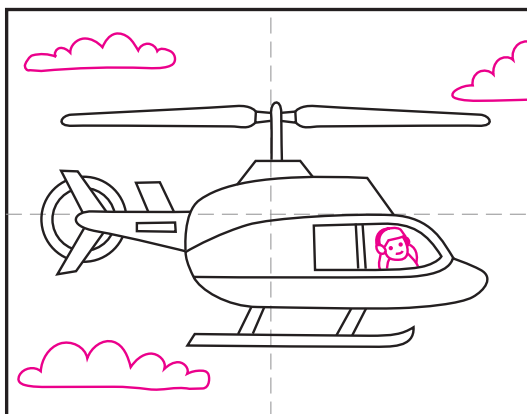

8. Finish with a pilot and add clouds all around.



9. Trace with a marker and color.

Helicopter

